

0.5 A, floating boost LED driver board based on the LED6000

Data brief

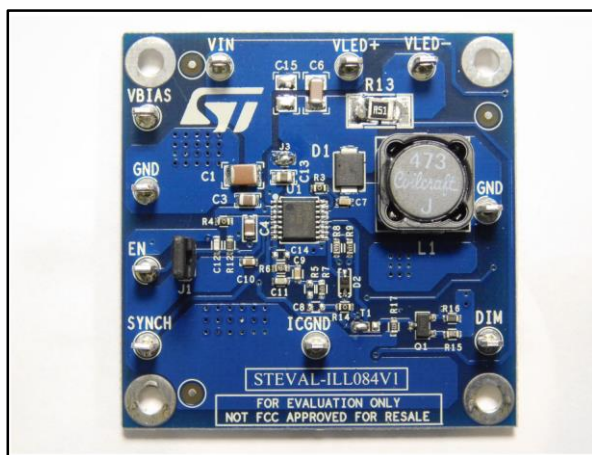

Features

- 18 V to 36 V input voltage
- Step-up conversion (up to 15 LEDs)
- 0.5 A programmed LED current
- 500 kHz switching frequency
- Digital dimming
- Compliant with ceramic output capacitors
- 180° out-of-phase synchronization available
- Auto recovery overcurrent and thermal protection
- RoHS compliant

Description

The STEVAL-ILL084V1 product evaluation board is based on the LED6000 monolithic current source for high power LED driving. The floating boost topology can benefit from the LED6000 wide input voltage range to drive many power LED in series. The LED6000 is a 61 V asynchronous switching regulator with embedded power MOSFET, designed to supply up to 3 A DC currents depending on the application conditions. The 250 mV typical R_{SENSE} voltage drop, embedded switch-over feature on the V_{BIAS} pin and light load management (pulse skipping) maximize power conversion efficiency across the entire load range. Digital dimming is implemented by driving the dedicated DIM pin.

The current limit threshold and the switching frequency are adjustable for application optimization. The device includes an internal 250 kHz oscillator that can be externally adjusted up to 1.5 MHz. The size of the overall application is minimized thanks to the high switching frequency and its compatibility with ceramic output capacitors. Two LED6000 regulators can be synchronized in a 180° out-of-phase configuration for reduced total input RMS current.

1 Schematic diagram

Figure 1: STEVAL-ILL084V1 circuit schematic

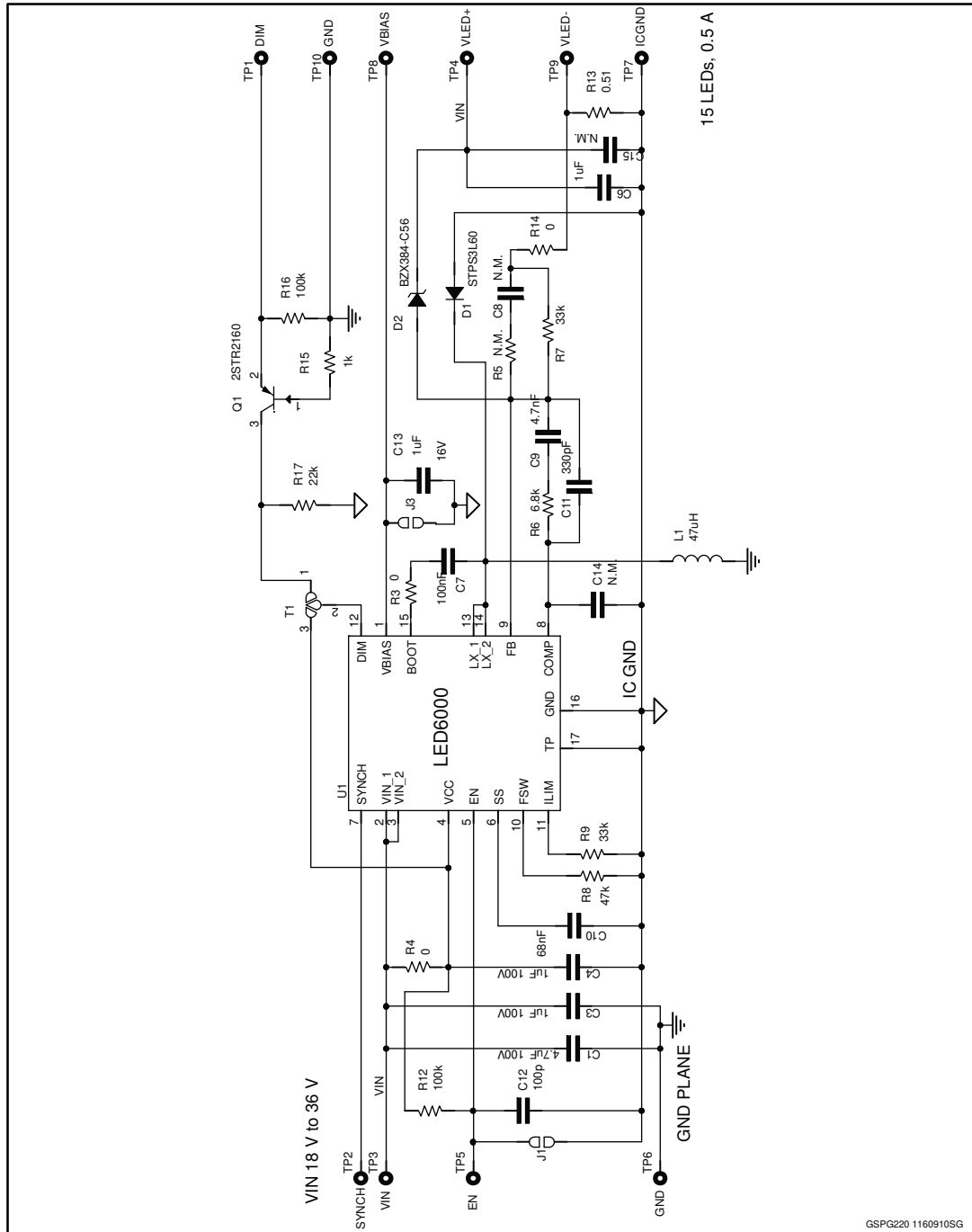

GSPG220 1160910SG

2 Revision history

Table 1: Document revision history

Date	Version	Changes
25-Jan-2016	1	Initial release.

IMPORTANT NOTICE – PLEASE READ CAREFULLY

STMicroelectronics NV and its subsidiaries ("ST") reserve the right to make changes, corrections, enhancements, modifications, and improvements to ST products and/or to this document at any time without notice. Purchasers should obtain the latest relevant information on ST products before placing orders. ST products are sold pursuant to ST's terms and conditions of sale in place at the time of order acknowledgement.

Purchasers are solely responsible for the choice, selection, and use of ST products and ST assumes no liability for application assistance or the design of Purchasers' products.

No license, express or implied, to any intellectual property right is granted by ST herein.

Resale of ST products with provisions different from the information set forth herein shall void any warranty granted by ST for such product.

ST and the ST logo are trademarks of ST. All other product or service names are the property of their respective owners.

Information in this document supersedes and replaces information previously supplied in any prior versions of this document.

© 2016 STMicroelectronics – All rights reserved