

DC Brushed Motor Driver

36V 1 Channel (1A/2A/3A)

DC Brushed Motor Driver

BD621x0AEFJ Evaluation Board

Introduction

This user's guide will provide the necessary steps to operate the Evaluation Board of ROHM's BD621x0AEFJ DC Brushed Motor Driver. This document includes the external parts, operating procedures and application data.

Description

This Evaluation Board was developed for ROHM's family of DC Brushed Motor Driver: BD62130AEFJ (3A), BD62120AEFJ (2A) and BD62110AEFJ (1A).

BD621x0AEFJ are built-in 1 channel H bridge motor drivers for DC brushed motors. This family of driver can drive high efficiency by a PWM signal directly to input pins. There are built in protection circuits in this IC. Each protection circuit operation contributes to set high reliability.

Application

Small appliances (Vacuum cleaners), Factory Automation, Robotics, Point of Sales (POS) machines, Gaming Machines, Scanners, Printers (Multi-function Printer, Laser Printer, Inkjet Printer, Photo Printer, FAX, Mini Printer), Plain Paper Copier (PPC), and any application that requires motor drivers for DC Brushed Motor.

Evaluation board operating condition (default setting)

Table 1. Evaluation board operating condition (default setting)

Parameter	Power supply voltage *1			Unit	Output current	Peak output current	Unit
	Min	Typ	Max		Max	Max	
BD62110AEFJ	8	-	28	V	1	2	A
BD62120AEFJ	8	-	28	V	2	3	A
BD62130AEFJ	8	-	28	V	3	4	A

*1 This indicates the voltage near the VCC pin. Be careful of voltage drop by the impedance of power line.

Evaluation board

The name shown on the PCB denotes which variant of the ROHM motor driver chip is mounted.

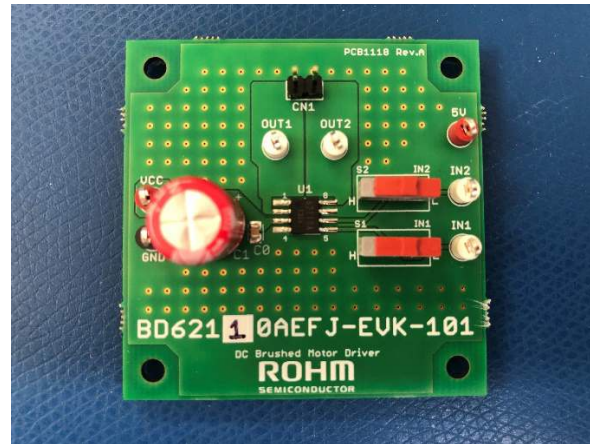

Figure 1. Top view of BD62110AEFJ-EVK-101

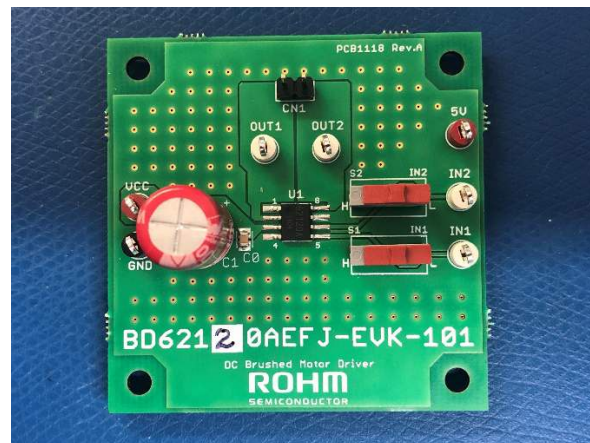

Figure 2. Top view of BD62120AEFJ-EVK-101



Figure 3. Top view of BD62130AEFJ-EVK-101

Evaluation board setup

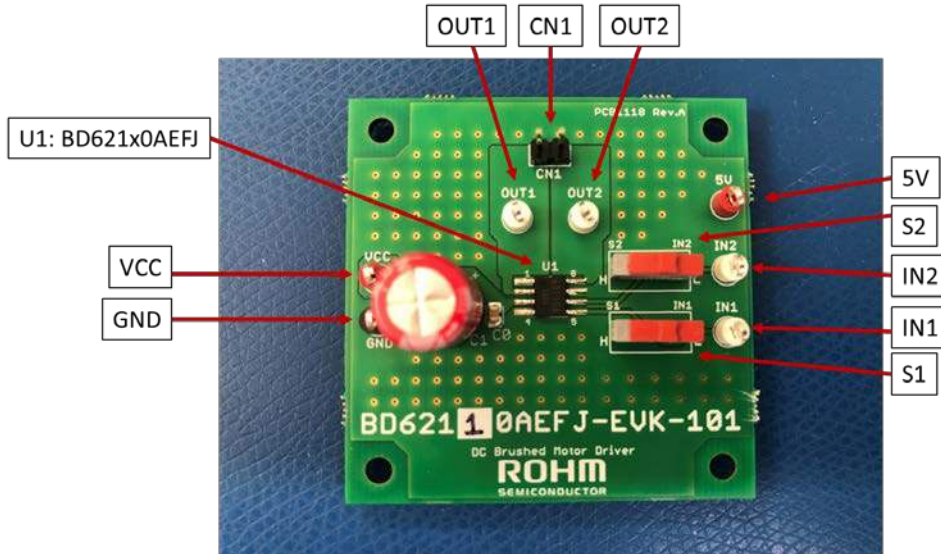

Figure 4. Evaluation board setup – test points, connectors, and switches S1 and S2

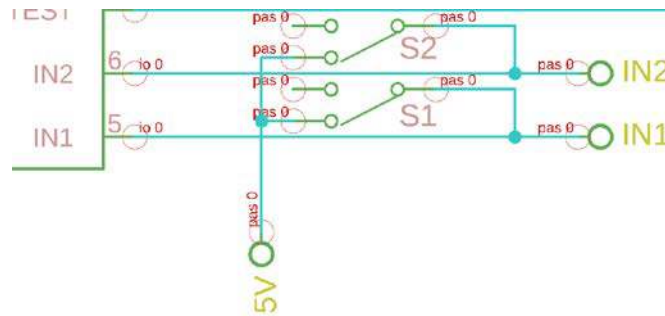

Figure 5. Evaluation board setup – Switches S1 and S2 are used to connect IN1 and IN2 pin to either 5V (“H”) or as open (“L”). When connected as open (“L”) and internal pulldown resistor will pull IN1 and IN2 to ground if nothing is connected to IN1 and IN2 test points.

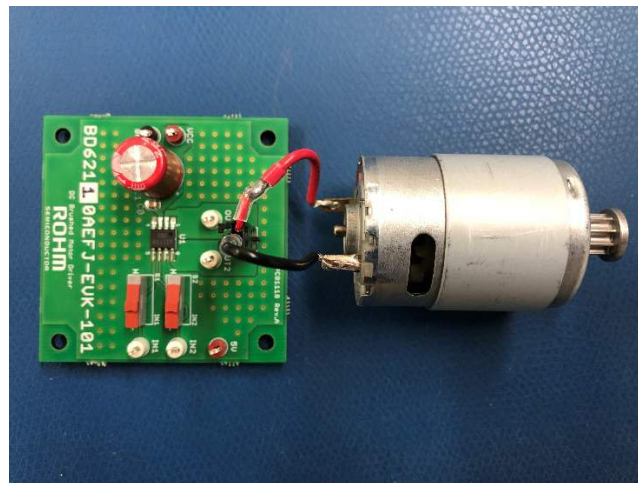

Figure 6. Evaluation board setup – connection to a DC brushed motor via connector CN1

Function explanation: Input and Output Table

Table 2. Input and Output operation table

Input		Output		State
IN1	IN2	OUT1	OUT2	
L	L	OPEN	OPEN	STOP
H	L	H	L	FORWARD
L	H	L	H	REVERSE
H	H	L	L	BRAKE

Function explanation: Slow and Fast Decay external PWM operation

Table 3. Slow and Fast Decay

SLOW DECAY (forward rotation)

Input		Output		State
IN1	IN2	OUT1	OUT2	
H	L	H	L	ON
H	H	L	L	SLOW DECAY
H	L	H	L	ON
H	H	L	L	SLOW DECAY
H	L	H	L	ON

FAST DECAY (synchronous rectification, forward rotation)

Input		Output		State
IN1	IN2	OUT1	OUT2	
H	L	H	L	ON
L	H	L	H	FAST DECAY
H	L	H	L	ON
L	H	L	H	FAST DECAY
H	L	H	L	ON

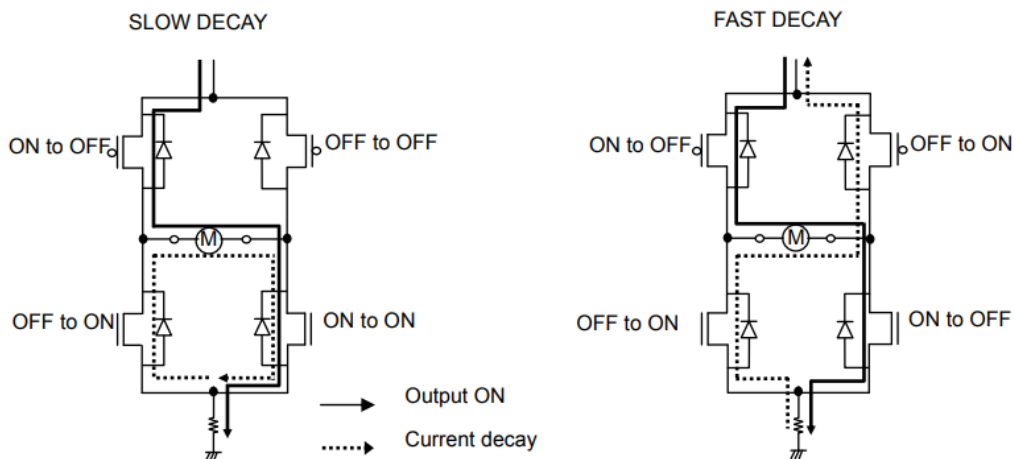

Operating procedure: Using Switches to control IN1 and IN2

1. Connect a DC brushed motor to connector CN1 (or to OUT1 and OUT2 test points) using wires.
2. Connect power supply between VCC and GND test points.
3. Connect a separate 5V to 5V test point.
4. Operate the switches "S1" and "S2" based on Input and Output operation shown in Table 2.

Operating procedure: Using external PWM signal to control IN1 and IN2

1. Connect a DC brushed motor to connector CN1 (or to OUT1 and OUT2 test points) using wires.
2. Connect power supply between VCC and GND test points.
3. Ensure that the switches S1 and S2 are pointed towards the "L" position (right side) so that IN1 and IN2 are not connected to 5V. See Figure 5 for description.
4. Connect an external microcontroller to IN1 and IN2 test points.
5. Operate the DC brushed motor based on Table 3 suggestion.

Pin configuration

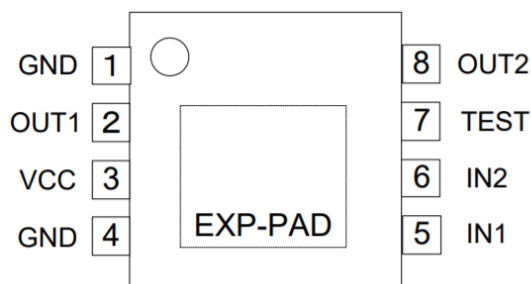

Figure 7. Pin configuration

Table 4. Pin Descriptions

Pin No.	Pin Name	Function	Pin No.	Pin name	Function
1	GND	Ground terminal	5	IN1	H bridge control terminal
2	OUT1	H bridge output terminal	6	IN2	H bridge control terminal
3	VCC	Power supply terminal	7	TEST	Test terminal (Connected to GND)
4	GND	Ground terminal	8	OUT2	H bridge output terminal

Evaluation board schematic

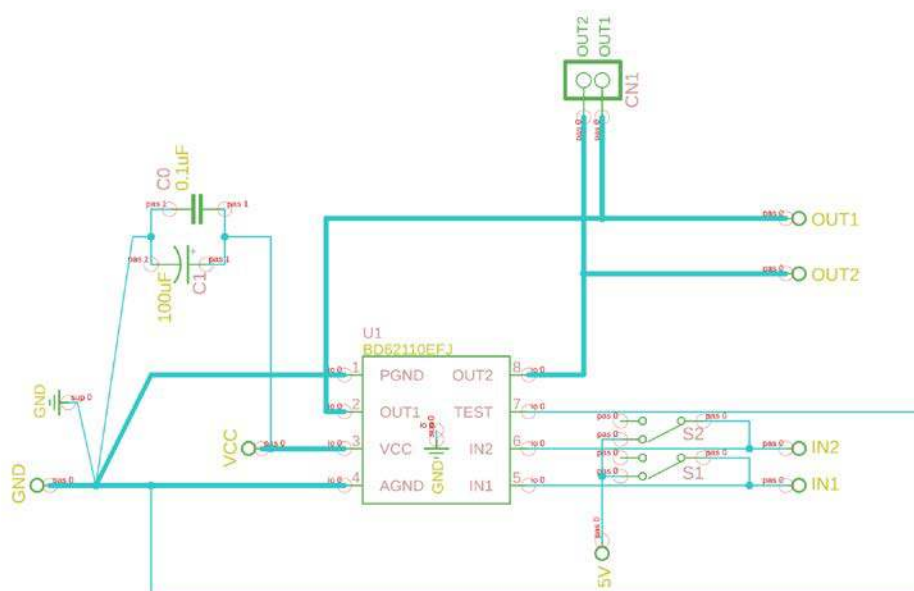

Figure 8. Evaluation board schematic

Parts list

Table 5. Parts list

Reference	Value	Description	Package Reference	MFG	PART NUMBER
C0	0.1µF	CAP CER 0.1UF 50V X7R 0805	0805 (2012 Metric)	WURTH	885012207098
C1	100µF 63V 20%	CAP ALUM 100UF 20% 63V RADIAL	5.0mm lead spacing, 10mm diameter	WURTH	860010775014
CN1	JUMPER	CONN HEADER VERT 2POS 2.54MM	2 position 0.100" (2.54mm)	WURTH	61300211121
S1, S2	SPDT On-On	SWITCH SLIDE SPDT 500MA 12V	2.54mm lead spacing, 10mm body length	WURTH	450301014042
TP_VCC, TP_5V	Test_Pad	Test_Pad_Compact_Red	1.6mm hole	KEYSTONE	5005
TP_GND	Test_Pad	Test_Pad_Compact_Black	1.6mm hole	KEYSTONE	5006
TP_OUT1, TP_OUT2, TP_IN1, TP_IN2	Test_Pad	Test_Pad_Compact_White	1.6mm hole	KEYSTONE	5007
U1	BD62110AEFJ-E2 BD62120AEFJ-E2 BD62130AEFJ-E2	36V, DC Brushed Motor Driver (1A/2A/3A)	HTTSOP-8J	ROHM	BD62110AEFJ-E2 BD62120AEFJ-E2 BD62130AEFJ-E2

Board layout

Evaluation board PCB information

Material	FR-4
Board thickness	1.575mm
Copper thickness	1 oz
Number of layers	2
Board size	50X50mm
Minimum copper width	0.300mm
Minimum air gap	0.350mm
Minimum hole size	0.300mm

The layout of BD621x0AEFJ-EVK-101 is shown below.

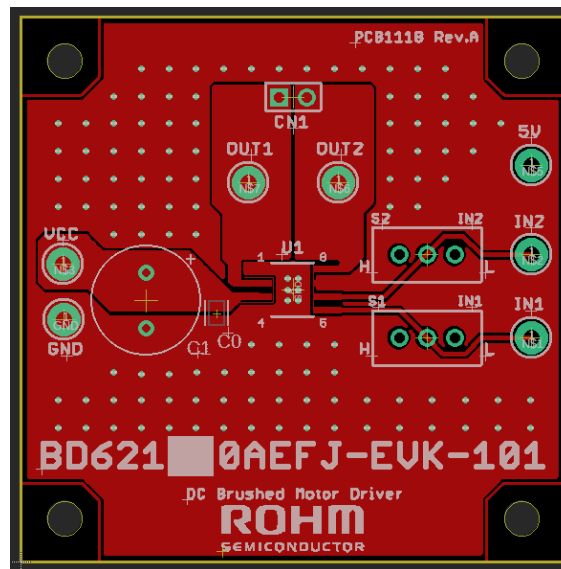

Figure 9. Top Layer and Top Silk Screen

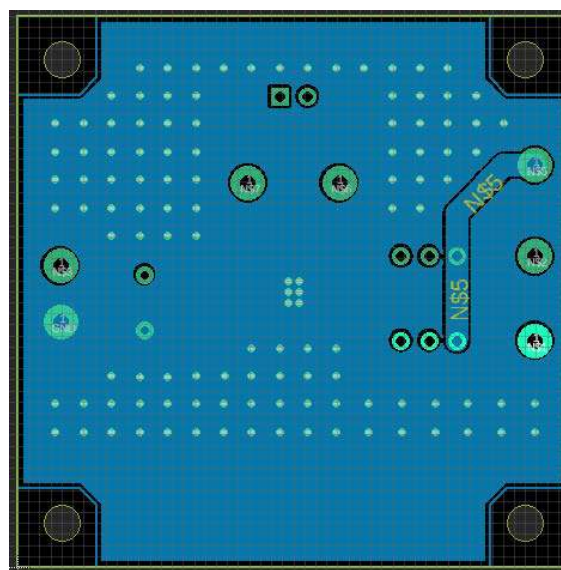

Figure 10. Bottom Layer

Revision history

Date	Revision number	Description
May 1, 2022	001	Initial release

Notes

- 1) The information contained herein is subject to change without notice.
- 2) Before you use our Products, please contact our sales representative and verify the latest specifications :
- 3) Although ROHM is continuously working to improve product reliability and quality, semiconductors can break down and malfunction due to various factors.
Therefore, in order to prevent personal injury or fire arising from failure, please take safety measures such as complying with the derating characteristics, implementing redundant and fire prevention designs, and utilizing backups and fail-safe procedures. ROHM shall have no responsibility for any damages arising out of the use of our Products beyond the rating specified by ROHM.
- 4) Examples of application circuits, circuit constants and any other information contained herein are provided only to illustrate the standard usage and operations of the Products. The peripheral conditions must be taken into account when designing circuits for mass production.
- 5) The technical information specified herein is intended only to show the typical functions of and examples of application circuits for the Products. ROHM does not grant you, explicitly or implicitly, any license to use or exercise intellectual property or other rights held by ROHM or any other parties. ROHM shall have no responsibility whatsoever for any dispute arising out of the use of such technical information.
- 6) The Products specified in this document are not designed to be radiation tolerant.
- 7) For use of our Products in applications requiring a high degree of reliability (as exemplified below), please contact and consult with a ROHM representative : transportation equipment (i.e. cars, ships, trains), primary communication equipment, traffic lights, fire/crime prevention, safety equipment, medical systems, servers, solar cells, and power transmission systems.
- 8) Do not use our Products in applications requiring extremely high reliability, such as aerospace equipment, nuclear power control systems, and submarine repeaters.
- 9) ROHM shall have no responsibility for any damages or injury arising from non-compliance with the recommended usage conditions and specifications contained herein.
- 10) ROHM has used reasonable care to ensure the accuracy of the information contained in this document. However, ROHM does not warrants that such information is error-free, and ROHM shall have no responsibility for any damages arising from any inaccuracy or misprint of such information.
- 11) Please use the Products in accordance with any applicable environmental laws and regulations, such as the RoHS Directive. For more details, including RoHS compatibility, please contact a ROHM sales office. ROHM shall have no responsibility for any damages or losses resulting non-compliance with any applicable laws or regulations.
- 12) When providing our Products and technologies contained in this document to other countries, you must abide by the procedures and provisions stipulated in all applicable export laws and regulations, including without limitation the US Export Administration Regulations and the Foreign Exchange and Foreign Trade Act.
- 13) This document, in part or in whole, may not be reprinted or reproduced without prior consent of ROHM.



Thank you for your accessing to ROHM product informations.
More detail product informations and catalogs are available, please contact us.

ROHM Customer Support System

<http://www.rohm.com/contact/>