



- Wide 2:1 Input Voltage Range
- High efficiency up to 88%
- 1500 VDC Isolation
- Over Current Protection
- No load consumption  $\leq 0.12W$
- Operating Temperature  $-40^{\circ}C$  to  $+85^{\circ}C$
- Output Over Voltage protection
- Continuous Short Circuit Protection
- Input Under Voltage Protection
- Remote On/Off control

## Models Single output



Model	Input Voltage (V)	Output Voltage (V)	Output Current max (A)	Isolation (VDC)	Max Capacitive Load ( $\mu F$ )	Efficiency (%)
AM10C-2405S-NZ	18-36	5	2	1500	2200	83
AM10C-2412S-NZ	18-36	12	0.83	1500	470	87
AM10C-2415S-NZ	18-36	15	0.66	1500	330	88
AM10C-2424S-NZ	18-36	24	0.41	1500	100	88

NOTE: All specifications in this datasheet are measured at an ambient temperature of  $25^{\circ}C$ , humidity  $<75\%$ , nominal input voltage and at rated output load unless otherwise specified.

## Input Specifications

Parameters	Nominal	Typical	Maximum	Units
Voltage range	24 Vin	18-36		VDC
Filter		Pi		
Absolute Maximum Rating (1s)	24 Vin		-0.7 - 50	VDC
No Load Input Current	24 Vin		12	mA
Input reflected ripple current	24 Vin	40		mA
Input Under voltage protection	24 Vin	15.5		VDC
Startup time	Nominal input, resistive load	10		ms
Remote On/Off Control	On Off	3.5-12VDC or leave open 0-1.2VDC or connect to GND, idle current 6-10mA		

## Isolation Specifications

Parameters	Conditions	Typical	Maximum	Units
Tested I/O voltage	60 sec, $<1mA$	1500		VDC
Resistance	500VDC		$>1000$	MOhm
Capacitance	I/O, 100KHz/0.1V	1000		pF

## Output Specifications

Parameters	Conditions	Typical	Maximum	Units
Voltage accuracy	5% to 100% load	$\pm 1$	$\pm 3$	%
Over voltage protection		110-160		% of Vout
Over current protection		110-190		% of Iout
Short Circuit protection		Continuous		
Short circuit restart		Auto-Recovery		
Line voltage regulation	Full load, LL to HL		$\pm 0.5$	% of Vin
Load voltage regulation	5% to 100% load		$\pm 1$	%
Temperature coefficient	100% load		$\pm 0.03$	%/ $^{\circ}C$
Ripple & Noise	20MHz Bandwidth, 5-100% load		100	mV p-p
Transient recovery time	25% load step change		500	$\mu s$
Transient recovery deviation	25% load step change		$\pm 5$	%

## General Specifications

Parameters	Conditions	Typical	Maximum	Units
Switching frequency	100% load	350		KHz
Operating temperature	See derating curve	-40 to +85		°C
Storage temperature		-55 to +125		°C
Maximum case temperature			100	°C
Cooling	Free air convection			
Humidity			95	% RH
Case material	Aluminum Alloy			
Weight	Pin mountable	15		g
Dimensions (L x W x H)	Pin mountable	1 x 1 x 0.46 inches	25.40 x 25.40 x 11.70 mm	
MTBF	>1,000,000 hours (MIL-HDBK -217F, Ground Benign, t=+25°C)			
Maximum soldering temperature	1.5mm from case for 10 sec		300	°C

## Environmental Specifications

Parameters		
Vibration	Test mode	10-55Hz
	Acceleration	10G, 30min one cycle, every axis tested

## Safety Specifications

Parameters		
Standards	Designed to meet IEC/EN/UL60950-1 EN 55022, class B (with the recommended EMC circuit)	
	Electrostatic Discharge Immunity	IEC 61000-4-2, Contact ±4KV, Criteria B
	RF, Electromagnetic Field Immunity	IEC 61000-4-3, 10V/m, Criteria A
	Electrical Fast Transient / Burst Immunity	IEC 61000-4-4, ±2KV, Criteria B (with the recommended EMC circuit)
	Surge Immunity	IEC 61000-4-5, ±2KV, Criteria B (with the recommended EMC circuit)
	RF, Conducted Disturbance Immunity	IEC 61000-4-6, 3 Vrms, Criteria A
	Voltage dips, Short Interruptions & Voltage variations Immunity	IEC 61000-4-29: 0-70%, Criteria B

## Dimensions

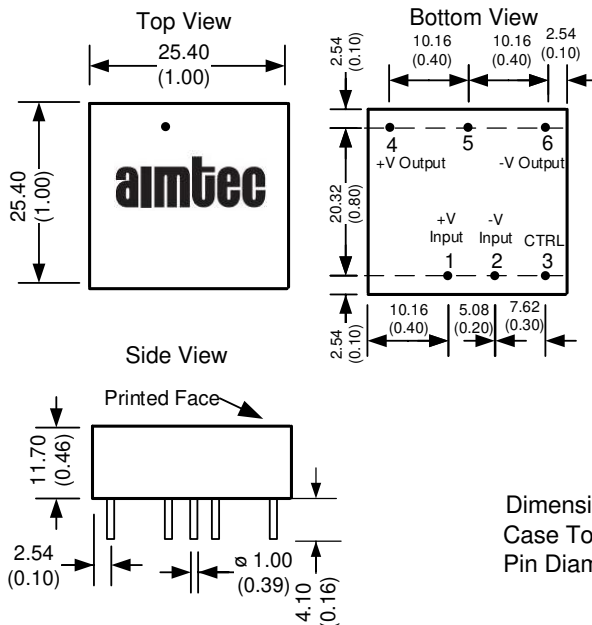

Dimensions mm (inch)  
Case Tolerance ±0.50 (±0.02)  
Pin Diameter 1.0 ± 0.10 (0.04 ± 0.004)

## Pin Out Specifications

Pin	Single
1	+V Input
2	-V Input
3	On/Off Control
4	+V Output
5	No pin
6	-V Output

## Derating

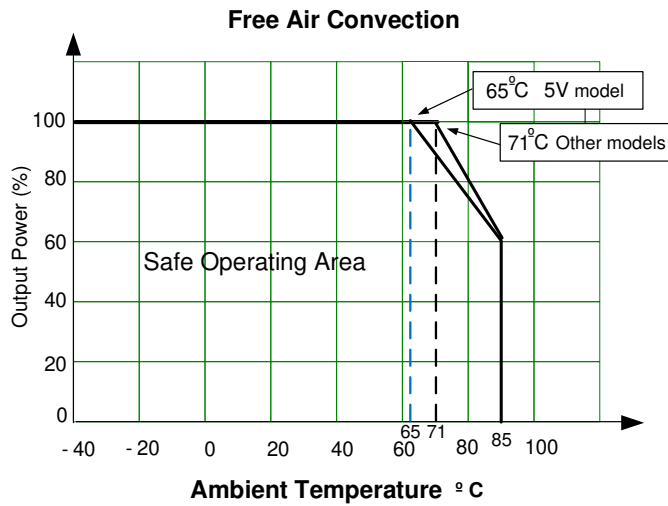

## Recommended EMC Circuits

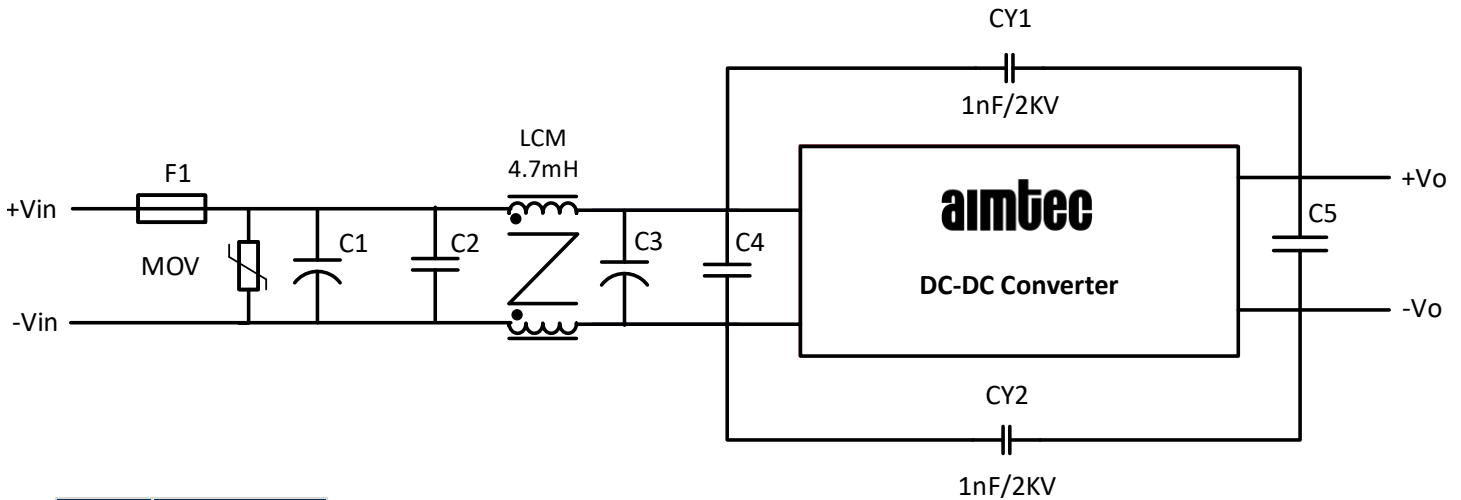

	24V input
MOV	S20K30
C1	680μF/50V
C2	1μF/50V
C3	330μF/50V
C4	4.7μF/50V
C5	10μF/50V

**NOTE:** 1. Datasheets are updated as needed and as such, specifications are subject to change without notice. Once printed or downloaded, datasheets are no longer controlled by Aimtec; refer to [www.aimtec.com](http://www.aimtec.com) for the most current product specifications. 2. Product labels shown, including safety agency certifications on labels, may vary based on the date manufactured. 3. Mechanical drawings and specifications are for reference only. 4. All specifications are measured at an ambient temperature of 25°C, humidity < 75%, nominal input voltage and at rated output load unless otherwise specified. 5. Aimtec may not have conducted destructive testing or chemical analysis on all internal components and chemicals at the time of publishing this document. CAS numbers and other limited information are considered proprietary and may not be available for release. 6. This product is not designed for use in critical life support systems, equipment used in hazardous environments, nuclear control systems or other such applications which necessitate specific safety and regulatory standards other than the ones listed in this datasheet. 7. Warranty is in accordance with Aimtec's standard Terms of Sale available at [www.aimtec.com](http://www.aimtec.com).