

# High Precision 4-Terminal Power Current Sensing Resistors with TCR as low as $\pm 3 \text{ ppm}/^\circ\text{C}$ Maximum, Tolerance to $\pm 0.5 \%$ and Load Life Stability $\pm 0.02 \%$ (200 ppm) at $25^\circ\text{C}$ , 2000 h at Rated Power

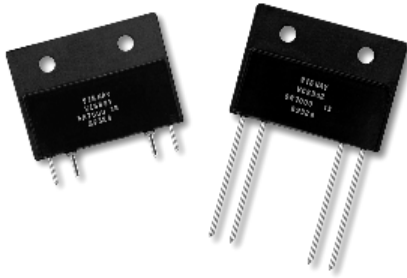

## INTRODUCTION

The VCS301 and VCS302 offer precision resistors as low as  $5 \text{ m}\Omega$  with a temperature coefficient down to  $3 \text{ ppm}/^\circ\text{C}$  maximum and unmatched long term stability. The 4 terminal current sensing resistors, when mounted on a heat sink, can sustain  $10 \text{ W}$  continuously without an appreciable change in resistance ( $0.15 \%$  maximum). The typical  $50 \%$  power derating specification associated with other technologies is not necessary. A choice of lead configurations is available.

Our application engineering department is available to advise and make recommendations. For non-standard technical requirements and special applications, please contact us.

## FEATURES

- Temperature coefficient of resistance (TCR): down to  $\pm 3 \text{ ppm}/^\circ\text{C}$  max. (see table 2)
- Tolerance: to  $\pm 0.5 \%$  (see table 1)
- Power rating (heat-sinked):  $10 \text{ W}$
- Load life stability:  $\pm 0.02 \%$  (200 ppm) at  $25^\circ\text{C}$ , 2000 h at rated power
- Resistance range:  $0.005 \Omega$  to  $0.25 \Omega$
- Vishay Foil resistors are not restricted to standard values; specific "as required" values can be supplied at no extra cost or delivery (e.g.  $0R123$  vs.  $0R1$ )
- Non inductive, non capacitive design
- Rise time:  $1.0 \text{ ns}$  effectively no ringing
- Thermal EMF:  $0.05 \mu\text{V}/^\circ\text{C}$  typical
- Voltage coefficient:  $< 0.1 \text{ ppm}/\text{V}$
- Non inductive:  $0.08 \mu\text{H}$
- Non hot spot design
- Terminal finish: lead (Pb)-free or tin/lead alloy
- Compliant to RoHS directive 2002/95/EC
- Prototype quantities available in just 5 working days or sooner. For more information, please contact [foil@vishaypg.com](mailto:foil@vishaypg.com)
- For better performances, please contact application engineering



RoHS\*  
COMPLIANT

**TABLE 1 - CHARACTERISTICS**

MODEL NUMBER	RESISTANCE RANGE	TOLERANCE (1)	POWER RATING (2) at $+25^\circ\text{C}$	MAXIMUM CURRENT (2)
VCS301, VCS302	$0.005 \Omega < R < 0.1 \Omega$	$\pm 1 \%$	$10 \text{ W}$ on heat sink (3)	$15 \text{ A}$
	$0.1 \Omega \leq R < 0.25 \Omega$	$\pm 0.5 \%$	or $3 \text{ W}$ in free air	

### Notes

1. Tighter tolerance is available - for more details contact application engineering
2. The lower of the two limitations (power or current) is decisive
3. Heatsink - aluminum ( $6''$  length x  $4''$  width x  $2''$  height x  $0.04''$  thick)

**TABLE 2 - TCR CHART (MAXIMUM)**

(0 °C TO + 60 °C)		
$\geq 0.005 \Omega$	to $< 0.01 \Omega$	$\pm 15 \text{ ppm}/^\circ\text{C}$
$\geq 0.01 \Omega$	to $< 0.05 \Omega$	$\pm 10 \text{ ppm}/^\circ\text{C}$
$\geq 0.05 \Omega$	to $< 0.1 \Omega$	$\pm 5 \text{ ppm}/^\circ\text{C}$
$\geq 0.1 \Omega$	to $< 0.25 \Omega$	$\pm 3 \text{ ppm}/^\circ\text{C}$

**FIGURE 1 - POWER DERATING CURVE**

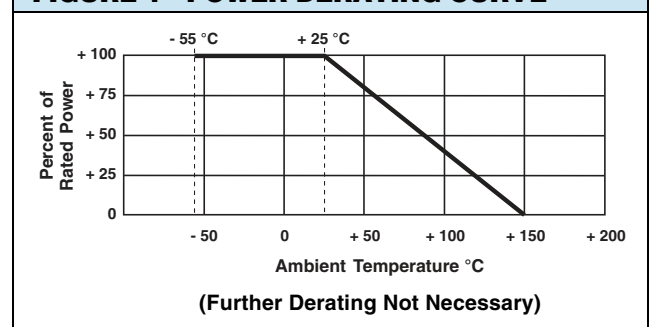

\* Pb containing materials are not RoHS compliant, exemptions may apply

**FIGURE 2 - DIMENSIONS** in inches (millimeters) **AND SCHEMATIC**

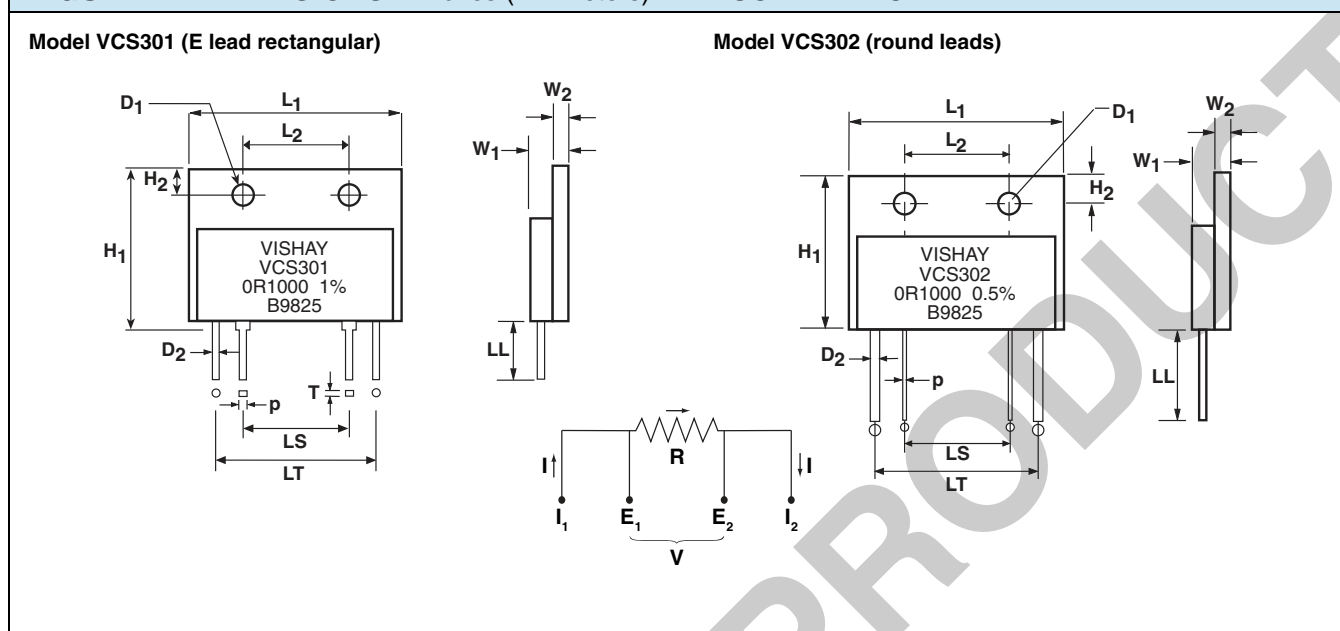

MODEL	L <sub>1</sub> ± 0.008 (± 0.20)	L <sub>2</sub> ± 0.008 (± 0.20)	H <sub>1</sub> MAXIMUM	H <sub>2</sub> ± 0.008 (± 0.20)	W <sub>1</sub> MAXIMUM	W <sub>2</sub> MAXIMUM	LL MINIMUM	LS ± 0.020 (± 0.51)	LT ± 0.020 (± 0.51)	D <sub>1</sub> NOMINAL	D <sub>2</sub> NOMINAL	P NOMINAL	T NO
VCS301	1.340 (34.04)	0.701 (17.81)	1.063 (27.00)	0.197 (5.00)	0.210 (5.33)	0.087 (2.21)	0.216 (5.49)	0.689 (17.50)	1.083 (27.51)	0.138 (3.51)	0.040 (1.02)	0.040 (1.02)	0.016 (0.41)
VCS302	1.340 (34.04)	0.701 (17.81)	1.024 (26.01)	0.197 (5.00)	0.210 (5.33)	0.087 (2.21)	1.000 (25.40)	0.689 (17.50)	1.083 (27.51)	0.138 (3.51)	0.040 (1.02)	0.032 (0.81)	-

**TABLE 3 - VISHAY VCS301, VCS302 PERFORMANCE**

TEST OR CONDITION	VCS301, VCS302 PERFORMANCE <sup>(1)</sup>	
	TYPICAL ΔR LIMITS	MAXIMUM ΔR LIMITS
Thermal Shock	0.01 %	0.02 %
Short Time Overload (5 x Rated Power for 5 s)	0.01 %	0.02 %
Terminal Strength	0.02 %	0.05 %
High Temperature Exposure (2000 h at 150 °C)	0.02 %	0.05 %
Moisture Resistance	0.03 %	0.05 %
Low Temperature Storage (24 h at - 55 °C)	0.005 %	0.01 %
Shock (Specified Pulse)	0.01 %	0.02 %
Vibration (High Frequency)	0.01 %	0.02 %
Load Life (Rated Power, + 25 °C, 2000 h)	0.02 %	0.05 %
Resistance Tolerance	0.5 %	1 %
Thermal EMF	0.2 μV/°C max. (E terminal)	
Weight	8.1 g maximum	

**Notes**

- ΔR's plus additional 0.0005 Ω for measurement error
- All measurements done in free air

**TABLE 4 - GLOBAL PART NUMBER INFORMATION (1)**

**NEW GLOBAL PART NUMBER: Y09590R25000D9L (preferred part number format)**

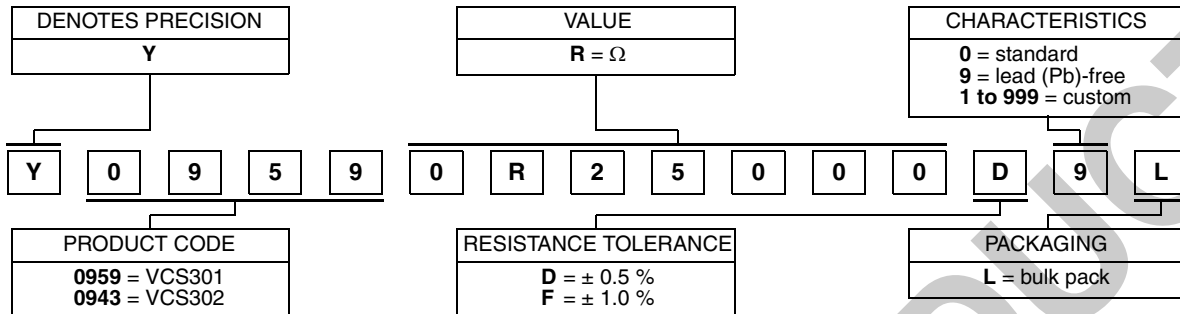

FOR EXAMPLE: ABOVE GLOBAL ORDER Y0959 0R25000 D 9 L:

TYPE: VCS301  
VALUE: 0.25 Ω  
ABSOLUTE TOLERANCE: ± 0.5 %  
TERMINATION: lead (Pb)-free  
PACKAGING: bulk

**HISTORICAL PART NUMBER: VCS301T 0R2500 D B (will continue to be used)**

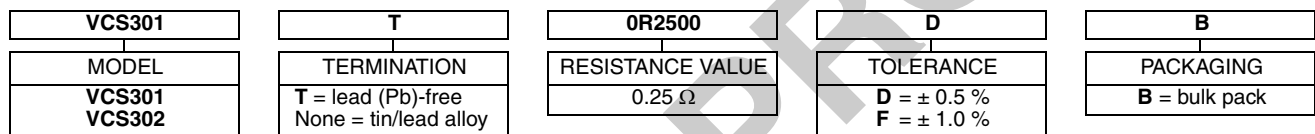

**Note**

(1) For non-standard requests, please contact application engineering

## Disclaimer

ALL PRODUCTS, PRODUCT SPECIFICATIONS AND DATA ARE SUBJECT TO CHANGE WITHOUT NOTICE.

Vishay Precision Group, Inc., its affiliates, agents, and employees, and all persons acting on its or their behalf (collectively, "VPG"), disclaim any and all liability for any errors, inaccuracies or incompleteness contained herein or in any other disclosure relating to any product.

The product specifications do not expand or otherwise modify VPG's terms and conditions of purchase, including but not limited to, the warranty expressed therein.

VPG makes no warranty, representation or guarantee other than as set forth in the terms and conditions of purchase. **To the maximum extent permitted by applicable law, VPG disclaims (i) any and all liability arising out of the application or use of any product, (ii) any and all liability, including without limitation special, consequential or incidental damages, and (iii) any and all implied warranties, including warranties of fitness for particular purpose, non-infringement and merchantability.**

Information provided in datasheets and/or specifications may vary from actual results in different applications and performance may vary over time. Statements regarding the suitability of products for certain types of applications are based on VPG's knowledge of typical requirements that are often placed on VPG products. It is the customer's responsibility to validate that a particular product with the properties described in the product specification is suitable for use in a particular application. You should ensure you have the current version of the relevant information by contacting VPG prior to performing installation or use of the product, such as on our website at [vpgsensors.com](http://vpgsensors.com).

No license, express, implied, or otherwise, to any intellectual property rights is granted by this document, or by any conduct of VPG.

The products shown herein are not designed for use in life-saving or life-sustaining applications unless otherwise expressly indicated. Customers using or selling VPG products not expressly indicated for use in such applications do so entirely at their own risk and agree to fully indemnify VPG for any damages arising or resulting from such use or sale. Please contact authorized VPG personnel to obtain written terms and conditions regarding products designed for such applications.

Product names and markings noted herein may be trademarks of their respective owners.

Copyright Vishay Precision Group, Inc., 2014. All rights reserved.