



FOCUS LCDs
LCDs MADE SIMPLE®

Ph. 480-503-4295 | NOPP@FocusLCDs.com

TFT | OLED | CHARACTER | GRAPHIC | UWVD | SEGMENT | CUSTOM

TFT Display Module

Part Number

E104RB-RS1000-N

Overview:

- 10.4-inch TFT (288.92x41.5mm)
- 24-bit RGB Interfaces
- 1024x100 pixels
- 12:00 Viewing Angle
- White LED back-light
- Transmissive/ Normally White
- No Touch Panel
- 1000 NITS
- Controllers: HX8282, HX8678
- RoHS Compliant

Description

This is a color active matrix TFT (Thin Film Transistor) LCD (Liquid Crystal Display) that uses amorphous silicon TFT as a switching device. This model is composed of a transmissive type TFT LCD Panel, driver circuit and a backlight unit. The resolution of the 10.4" TFT LCD contains 1024(RGB)x100 pixels and can display up to 16.7M colors.

TFT Features

Low Input Voltage: 3.3V

Display Colors: 16.7M

TFT Interface: 24-bit RGB

General Information Items	Specification	Unit	Note
	Main Panel		
TFT Display area (AA)	264.192(H) x 25.8(V) (10.4 inch)	mm	-
Driver Element	TFT active matrix	-	-
Display Colors	16.7M	colors	-
Number of pixels	1024(RGB)x100	dots	-
TFT Pixel arrangement	RGB vertical stripe	-	-
Pixel Pitch	0.258(H)x0.258(V)	mm	-
Viewing angle	12:00	o'clock	-
Display mode	Transmissive, Normally white	-	-
TFT Controller	HX8282, HX8678	-	-
Operating temperature	0-+50	°C	-
Storage temperature	-10-+60	°C	-

Mechanical Information

Item		Min	Typ.	Max	Unit	Note
Module Size	Horizontal (H)		288.92		mm	-
	Vertical (V)		41.5		mm	-
	Depth (D)		6.89		mm	-
	Weight		97		g	

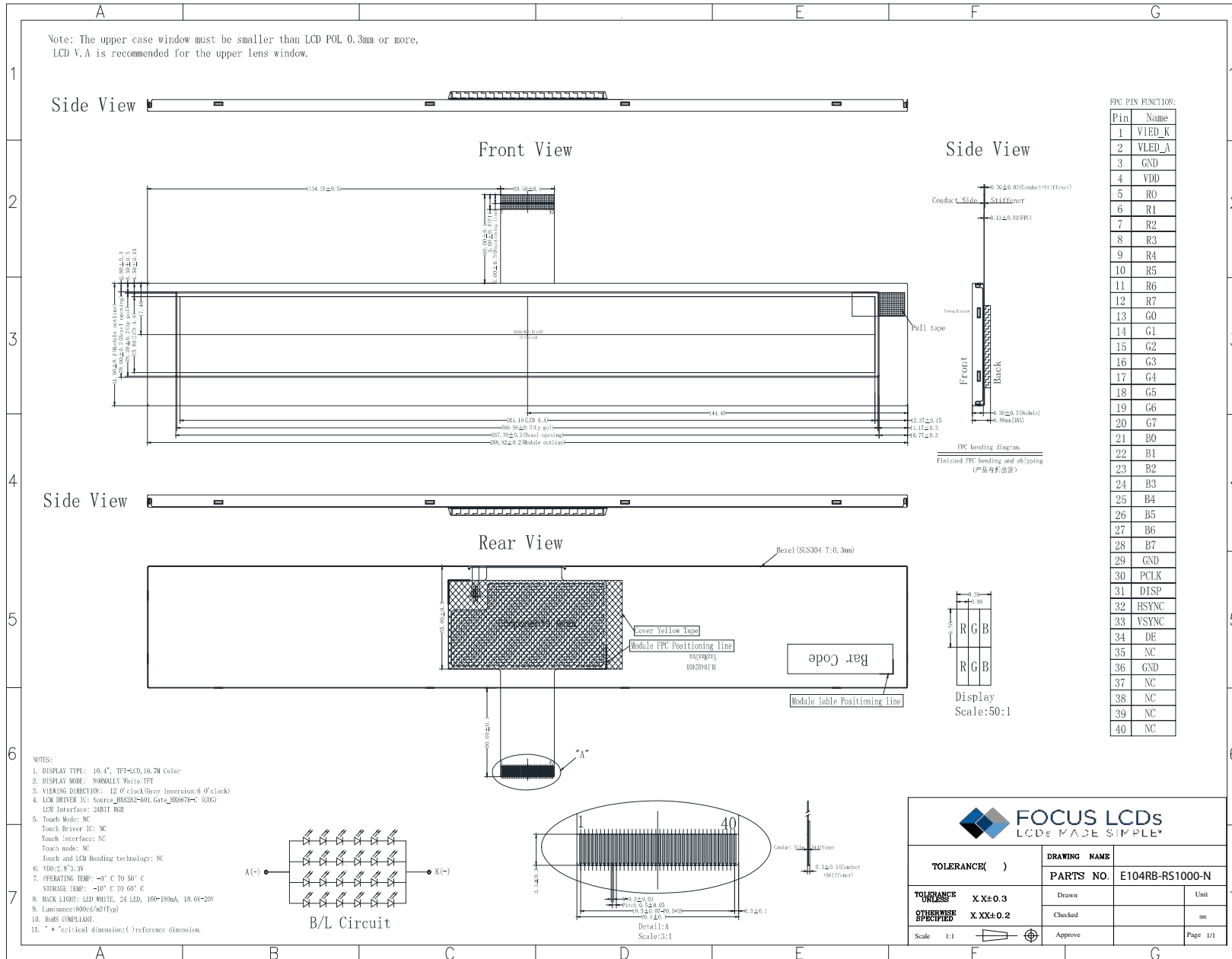

2. Input Terminal Pin Assignment

2.1 TFT

NO.	Symbol	Description	I/O
1	LEDK	Cathode pin of the backlight	P
2	LEDA	Anode pin of the backlight	P
3	GND	Ground	P
4	VDD	Input voltage	P
5-12	R0-R7	8-bit red data bus for the parallel RGB interface.	I/O
13-20	G0-G7	8-bit green data bus for the RGB parallel interface.	I/O
21-28	B0-B7	8-bit blue data bus for the RGB parallel interface	I/O
29	GND	Ground	P
30	PCLK	Pixel clock signal for the RGB interface	I
31	DISP	Display power control pin. H=power on. L=power off	I
32	HSYNC	Horizontal sync signal for the RGB interface. Negative polarity.	I
33	VSYNC	Vertical sync signal. Negative polarity.	I
34	DE	Data enable signal, active high.	I
35	NC		
36	GND	Ground	P
37	NC		
38	NC		
39	NC		
40	NC		

3. LCD Optical Characteristics

3.1 Optical Specifications

Item	Symbol	Condition	Min	Typ.	Max	Unit	Note	
Color Gamut	S	Normal viewing angle $\theta=0$	--	42	--	%	(3)	
Contrast Ratio	CR		300	500	--	%	(2)	
Response Time	Rising		T_R	--	25	50	ms	(4)
	Falling		T_F					
Color Filter Chromaticity	White		W_x	0.271	0.311	0.351		(5)(6)
			W_y	0.298	0.338	0.378		
	Red		R_x	0.522	0.562	0.602		
			R_y	0.296	0.336	0.376		
	Green		G_x	0.304	0.344	0.464		
			G_y	0.513	0.553	0.593		
	Blue	B_x	0.111	0.151	0.291			
		B_y	0.098	0.138	0.178			
Viewing Angle	Hor.	Θ_L	CR \geq 10	--	60	--	degrees	(1)(6)
		Θ_R		--	60	--		
	Ver.	Θ_T		--	60	--		
		Θ_B		--	50	--		
Option View Direction	12:00						(1)	

Optical Specification Reference Notes:

(1) Definition of Viewing Angle: The viewing angle is the angle at which the contrast ratio is greater than 10. The viewing angles are determined for the horizontal or 3,9 o'clock direction and the vertical or 6,12 o'clock direction with respect to the optical axis which is normal to the LCD surface.

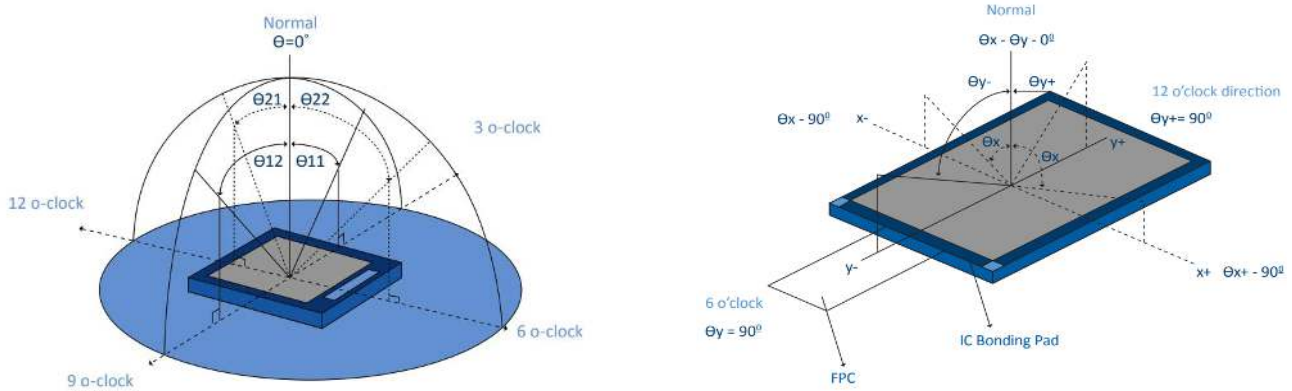

(2) Definition of Contrast Ratio (Cr): measured at the center point of panel. The contrast ratio (Cr) measured on a module, is the ratio between the luminance (Lw) in a full white area (R=G=B=1) and the luminance (Ld) in a dark area (R=G=B=0).

$$Cr = \frac{Lw}{Ld}$$

(3) Definition of transmittance (T%): The transmittance of the panel including the polarizers is measured with electrical driving. The equation for transmittance Tr is:

$$Tr = \frac{I_t}{I_o} \times 100\%$$

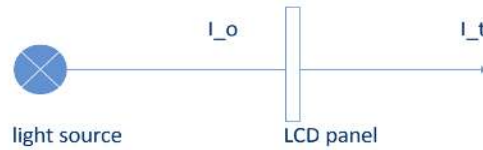

Io = the brightness of the light source.
 It = the brightness after panel transmission

(4) Definition of Response Time (Tr, Tf): The rise time 'Tr' is defined as the time for luminance to change from 90% to 10% as a result of a change of the electrical condition. The fall time 'Tf' is defined as the time for luminance to change from 10% to 90% as a result of a change of the electrical condition.

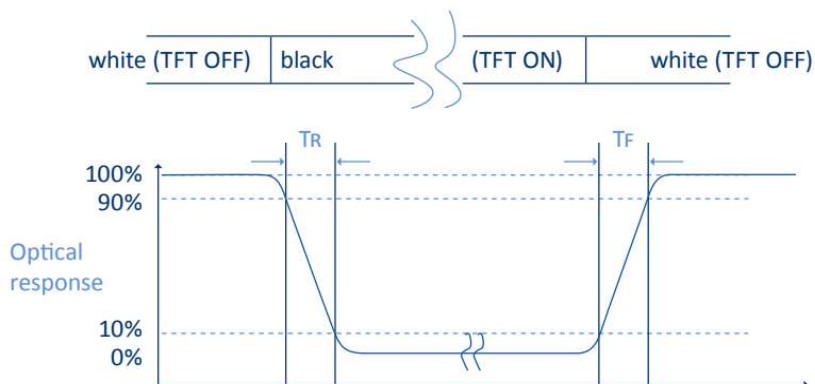

(5) Definition of Color Gamut:

Measuring machine CFT-01. NTSC's Primaries: $R(x,y,Y), G(x,y,Y), B(x,y,Y)$. FPM520 of Westar Display Technologies, INC., which utilized SR-3 for Chromaticity and BM-5A for other optical characteristics. The color chromaticity shall be calculated from the spectral data measured with all pixels first in red, green, blue and white. Measurements shall be made at the center of the panel.

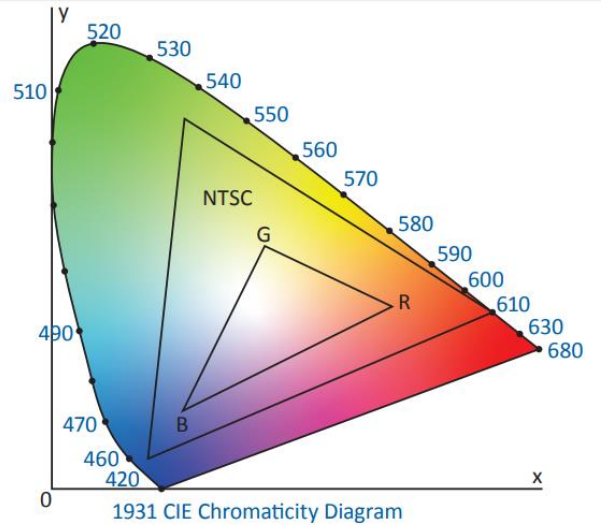
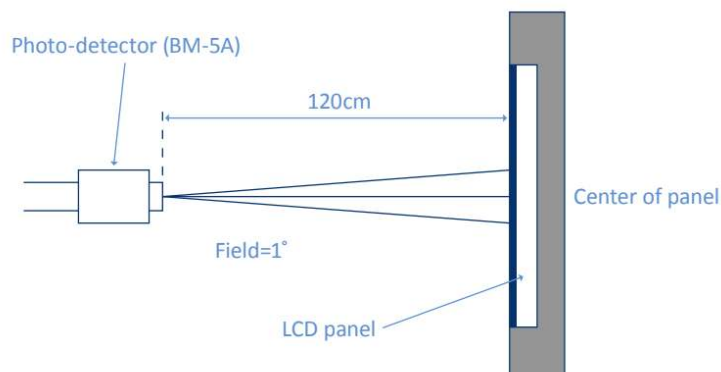
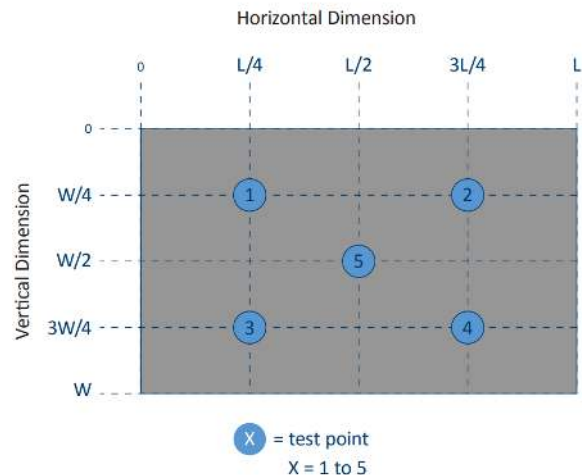
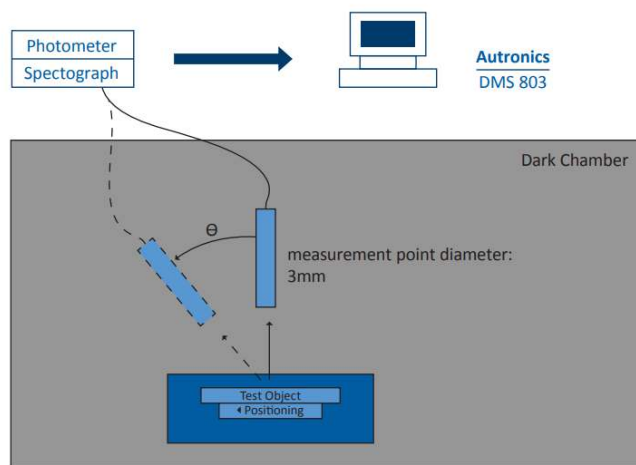

Fig. 1931 CIE chromacity diagram

$$\text{Color gamut: } S = \frac{\text{Area of RGB triangle}}{\text{Area of NTSC triangle}} \times 100\%$$

(6) Definition of Optical Measurement Setup:

The LCD module should be stabilized at a given temperature for 20 minutes to avoid abrupt temperature change during measuring. In order to stabilize the luminance, the measurement should be executed after lighting backlight for 20 minutes.



4. TFT Electrical Characteristics

4.1 Absolute Maximum Rating (Ta=25 °C, VSS=0V)

Characteristics	Symbol	Min	Max	Unit
Digital Supply Voltage	VCI	-0.5	3.96	V
Operating Temperature	TOP	0	+50	°C
Storage Temperature	TST	-10	+60	°C

NOTE: If the absolute maximum rating of the above parameters is exceeded, even momentarily, the quality of the product may be degraded. Absolute maximum ratings specify the values which the product may be physically damaged if exceeded. Be sure to use the product within the range of the absolute maximum ratings.

4.2 DC Electrical Characteristics

Characteristics	Symbol	Min	Typ.	Max	Unit	Note
Digital Supply Voltage	VDD	2.3	3.3	3.6	V	
Normal Mode Current	IDD	--	70	140	mA	
Level Input Voltage	V _{IH}	0.7VDD	--	VDD	V	
	V _{IL}	GND	--	0.3VDD	V	

4.3 LED Backlight Characteristics

The backlight system is edge lighting type with 12 chips white LED.

Item	Symbol	Min	Typ.	Max	Unit	Note
Forward Current	I _F	80	--	160	mA	
Forward Voltage	V _F	18.6	--	20	V	
LCM Luminance	LV	500	900	1000	cd/m ²	Note 3
LED lifetime	Hr	50000	--	--	hour	Note1 & 2
Uniformity	AV _g	80	--	--	%	Note 3

Note 1: LED lifetime (Hr) can be defined as the time in which it continues to operate under the condition: Ta=25 ±3 °C, typical IL value indicated in the above table until the brightness becomes less than 50%.

Note 2: The “LED lifetime” is defined as the module brightness decrease to 50% original brightness at Ta=25°C and IL = 160mA. The LED lifetime could be decreased if operating IL is larger than 160mA. The constant current driving method is suggested.

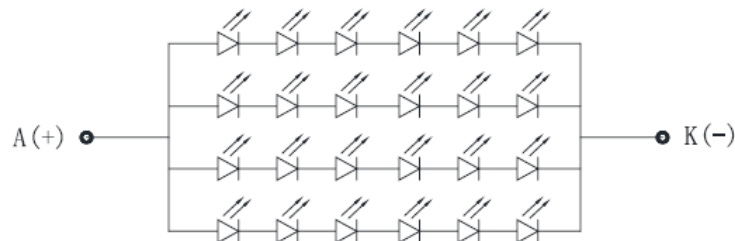

Note 3: Luminance Uniformity of these 9 points is defined as below:

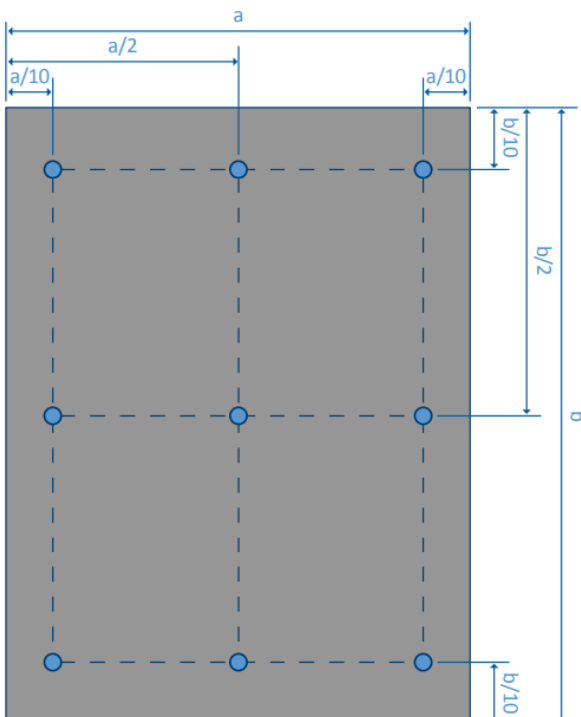

$$\text{Luminance} = \frac{\text{Total Luminance of 9 points}}{9}$$

$$\text{Uniformity} = \frac{\text{minimum luminance in 9 points(1-9)}}{\text{maximum luminance in 9 points(1-9)}}$$

5. AC Characteristics

5.1 RGB Data Bus Timing Signals

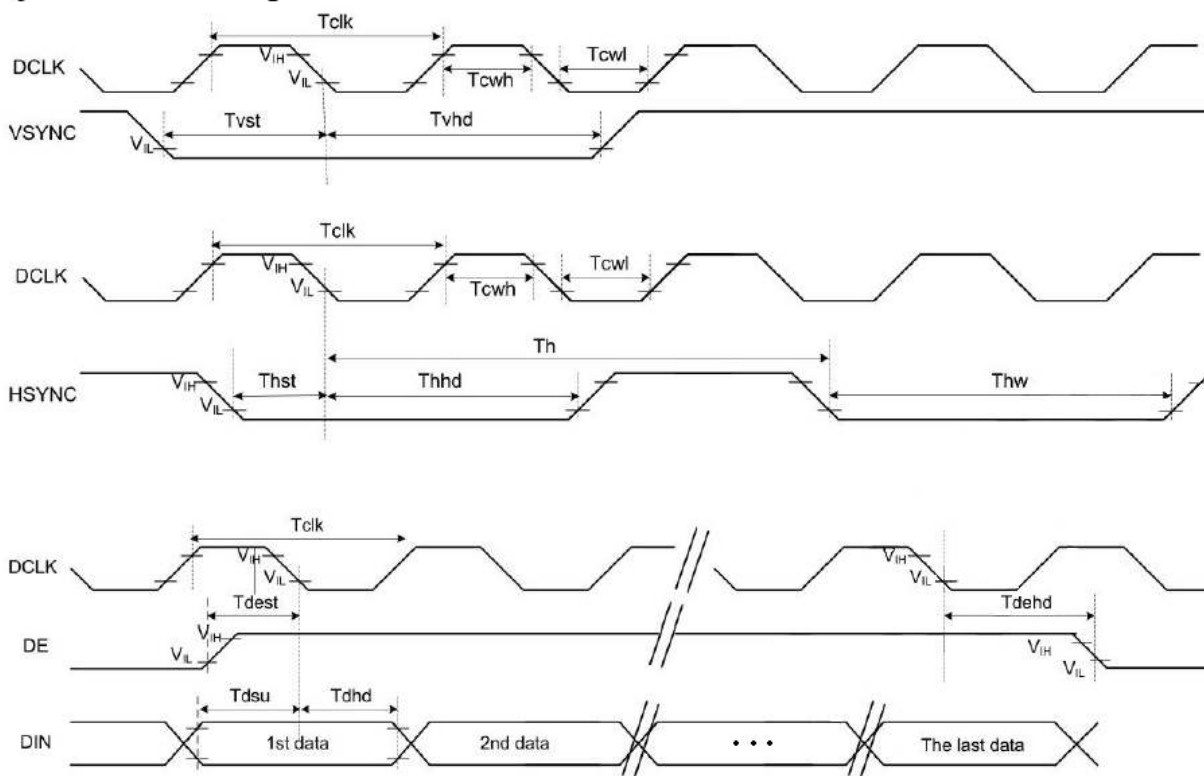

Item	Symbol	Min.	Typ.	Max.	Unit	Conditions
CLK Pulse Duty	T_{clk}	40	50	60	%	
HSYNC Width	T_{hw}	2	-	-	DCLK	
HSYNC Period	T_h	55	60	65	us	
VSYNC Setup Time	T_{vst}	5	-	-	ns	
VSYNC Hold Time	T_{vhd}	5	-	-	ns	
HSYNC Setup Time	T_{hst}	5	-	-	ns	
HSYNC Hold Time	T_{hhd}	5	-	-	ns	
Data Setup Time	T_{dsu}	5	-	-	ns	
Data Hold Time	T_{dhd}	5	-	-	ns	
DE Setup Time	T_{dest}	5	-	-	ns	
DE Hold Time	T_{dehd}	5	-	-	ns	

5.2 RGB SYNC Mode

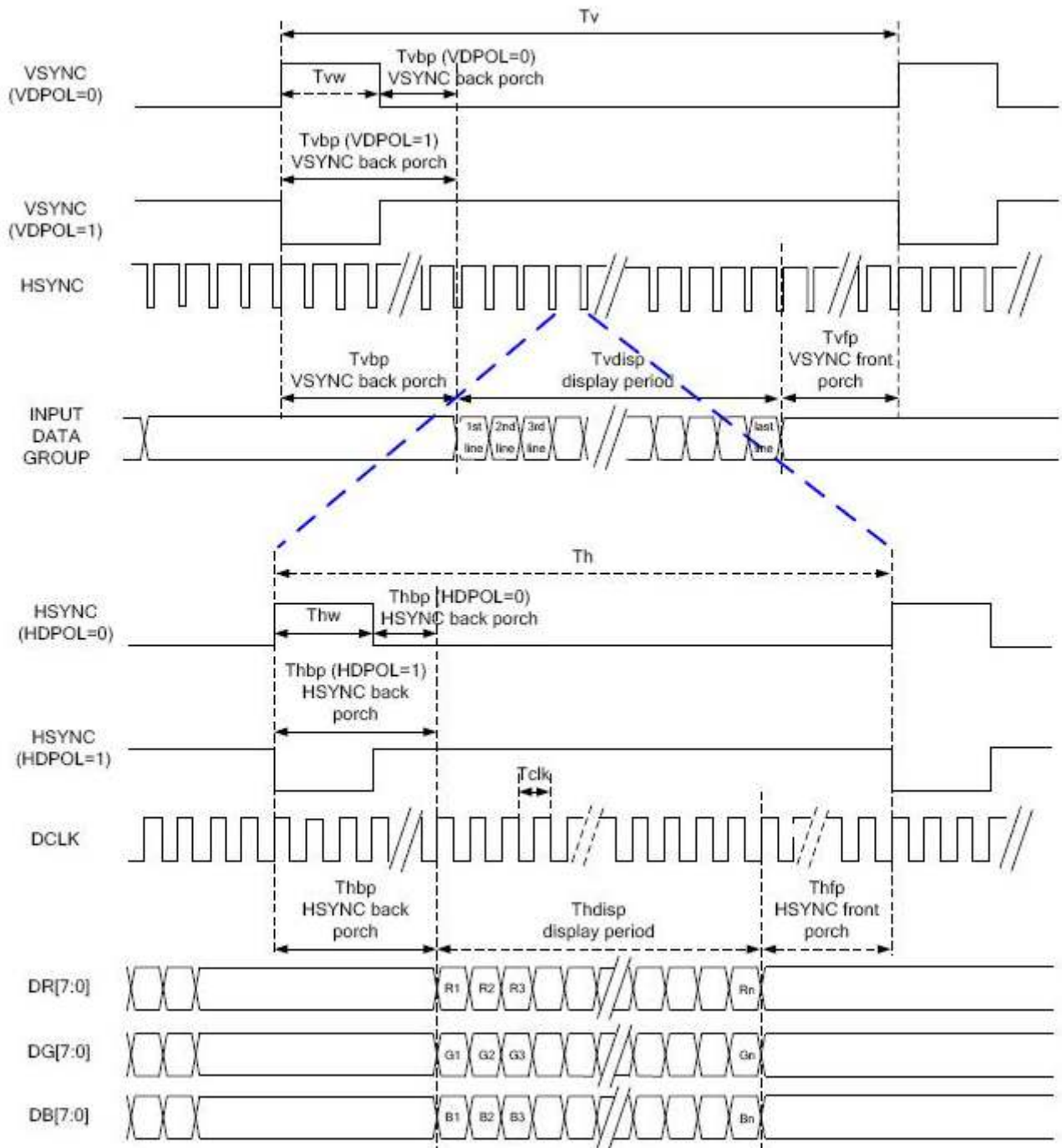

5.3 RGB SYNC-DE Mode

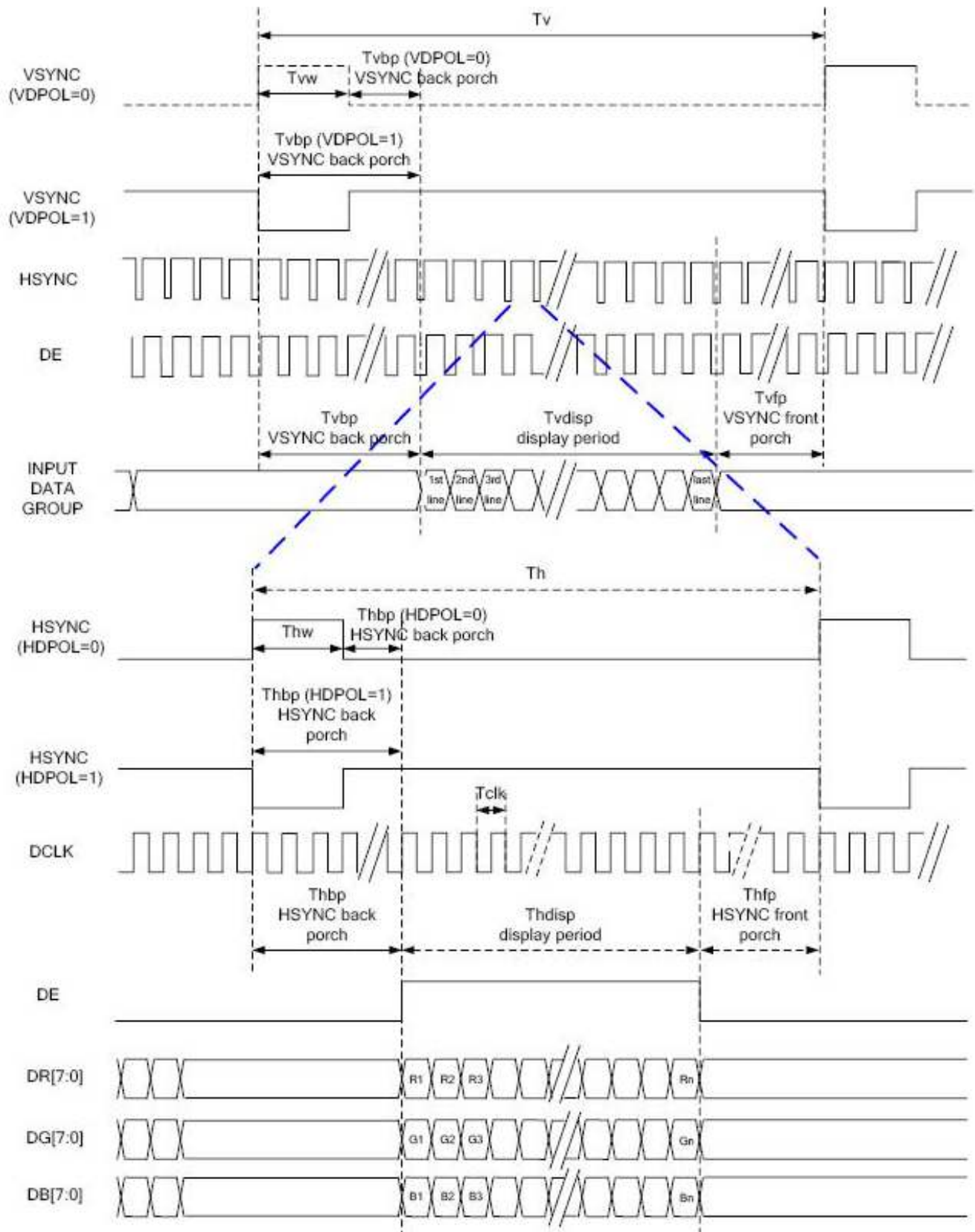

5.4 DE Mode

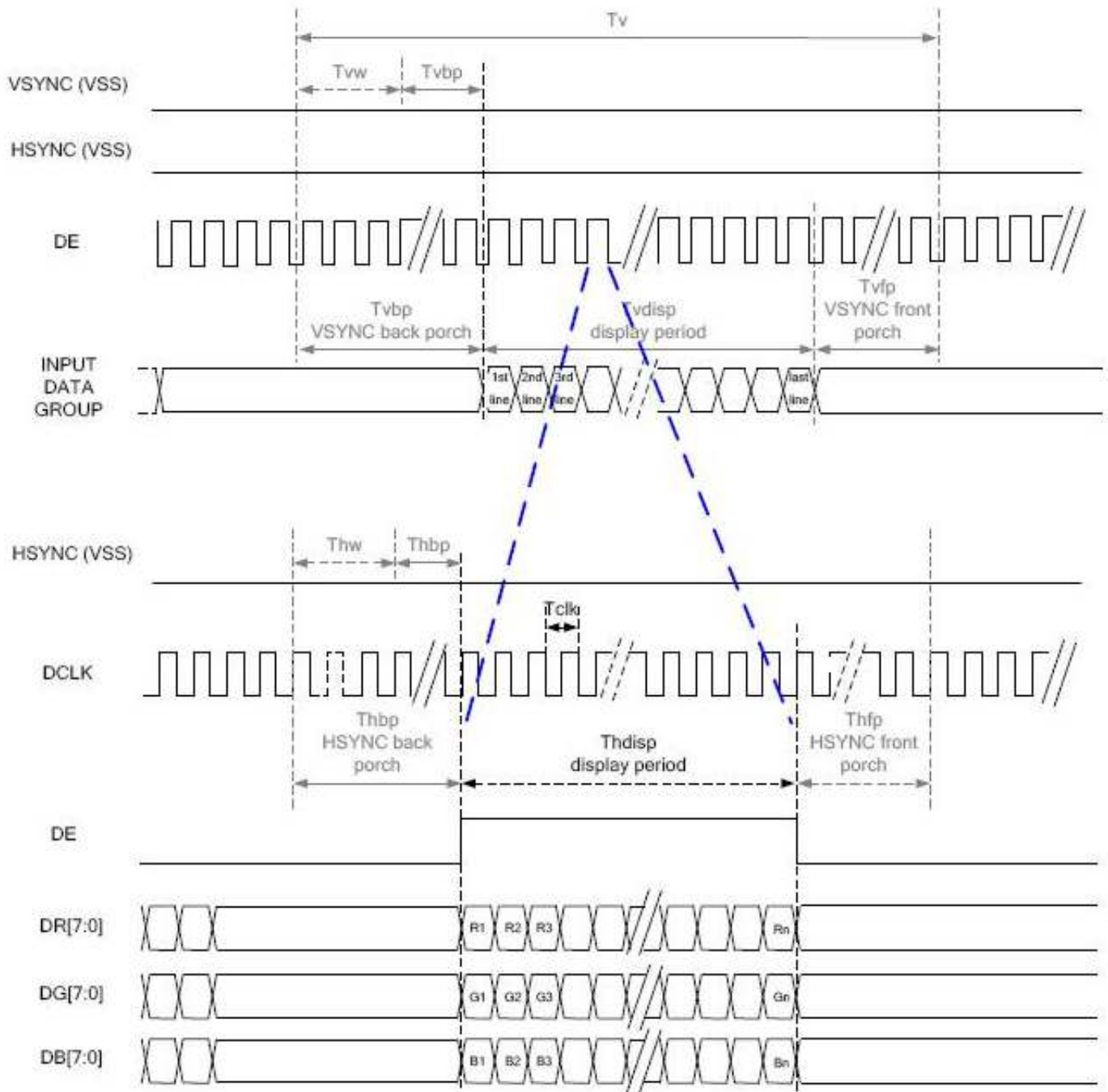

RGB Mode Selection	DCLK	HSYNC	VSYNC	DE
SYNC-DE Mode	Input	Input	Input	Input
SYNC Mode	Input	Input	Input	GND
DE Mode	Input	GND	GND	Input

5. 时序图. 时序图

Item	Symbol	Min.	Typ.	Max.	Unit	
Frame Rate	--	--	60.2	--	I ↑	
5/[Y C] ← 5 [H]	C_{DCLK}	--	21	--	MHz	
Horizontal	Total Line	α_H	--	1344	--	5/[Y
	Active Pixels	α_{Hact}	1024			5/[Y
	. Line α_{HPW}	α_{HPW}	--	158	--	5/[Y
	Pulse Width	α_{HBP}	--	1	--	5/[Y
	Front Porch	α_{HFP}	--	161	--	5/[Y
Vertical	Total Time	$\alpha_{\uparrow\downarrow}$	--	258	--	H
	Active Lines	α_{Vact}	130			H
	. Line α_{VPW}	α_{VPW}	--	21	--	H
	Pulse Width	α_{VBP}	--	2	--	H
	Front Porch	α_{VFP}	--	105	--	H

Note: Back porch is NOT included pulse width

6. Cautions and Handling Precautions

6.1 Handling and Operating the Module

1. When the module is assembled, it should be attached to the system firmly. Do not warp or twist the module during assembly work.
2. Protect the module from physical shock or any force. In addition to damage, this may cause improper operation or damage to the module and back-light unit.
3. Note that polarizer is very fragile and could be easily damaged. Do not press or scratch the surface.
4. Do not allow drops of water or chemicals to remain on the display surface. If you have the droplets for a long time, staining and discoloration may occur.
5. If the surface of the polarizer is dirty, clean it using some absorbent cotton or soft cloth.
6. The desirable cleaners are water, IPA (Isopropyl Alcohol) or Hexane. Do not use ketene type materials (ex. Acetone), Ethyl alcohol, Toluene, Ethyl acid or Methyl chloride. It might permanent damage to the polarizer due to chemical reaction.
7. If the liquid crystal material leaks from the panel, it should be kept away from the eyes or mouth. In case of contact with hands, legs, or clothes, it must be washed away thoroughly with soap.
8. Protect the module from static; it may cause damage to the CMOSICs.
9. Use fingerstalls with soft gloves in order to keep display clean during the incoming inspection and assembly process.
10. Do not disassemble the module.
11. Protection film for polarizer on the module shall be slowly peeled off just before use so that the electrostatic charge can be minimized.
12. Pins of I/F connector shall not be touched directly with bare hands.
13. Do not connect, disconnect the module in the "Power ON" condition.
14. Power supply should always be turned on/off by the item Power On Sequence & Power Off Sequence.

6.2 Storage and Transportation.

1. Do not leave the panel in high temperature, and high humidity for a long time. It is highly recommended to store the module with temperature from 0 to 35 °C and relative humidity of less than 70%
2. Do not store the TFT-LCD module in direct sunlight.
3. The module shall be stored in a dark place. When storing the modules for a long time, be sure to adopt effective measures for protecting the modules from strong ultraviolet radiation, sunlight, or fluorescent light.
4. It is recommended that the modules should be stored under a condition where no condensation is allowed. Formation of dewdrops may cause an abnormal operation or a failure of the module. In particular, the greatest possible care should be taken to prevent any module from being operated where condensation has occurred inside.
5. This panel has its circuitry FPC on the bottom side and should be handled carefully in order not to be stressed.