

Standard 212-pin MCU card with **TM4C129XNCZAD**

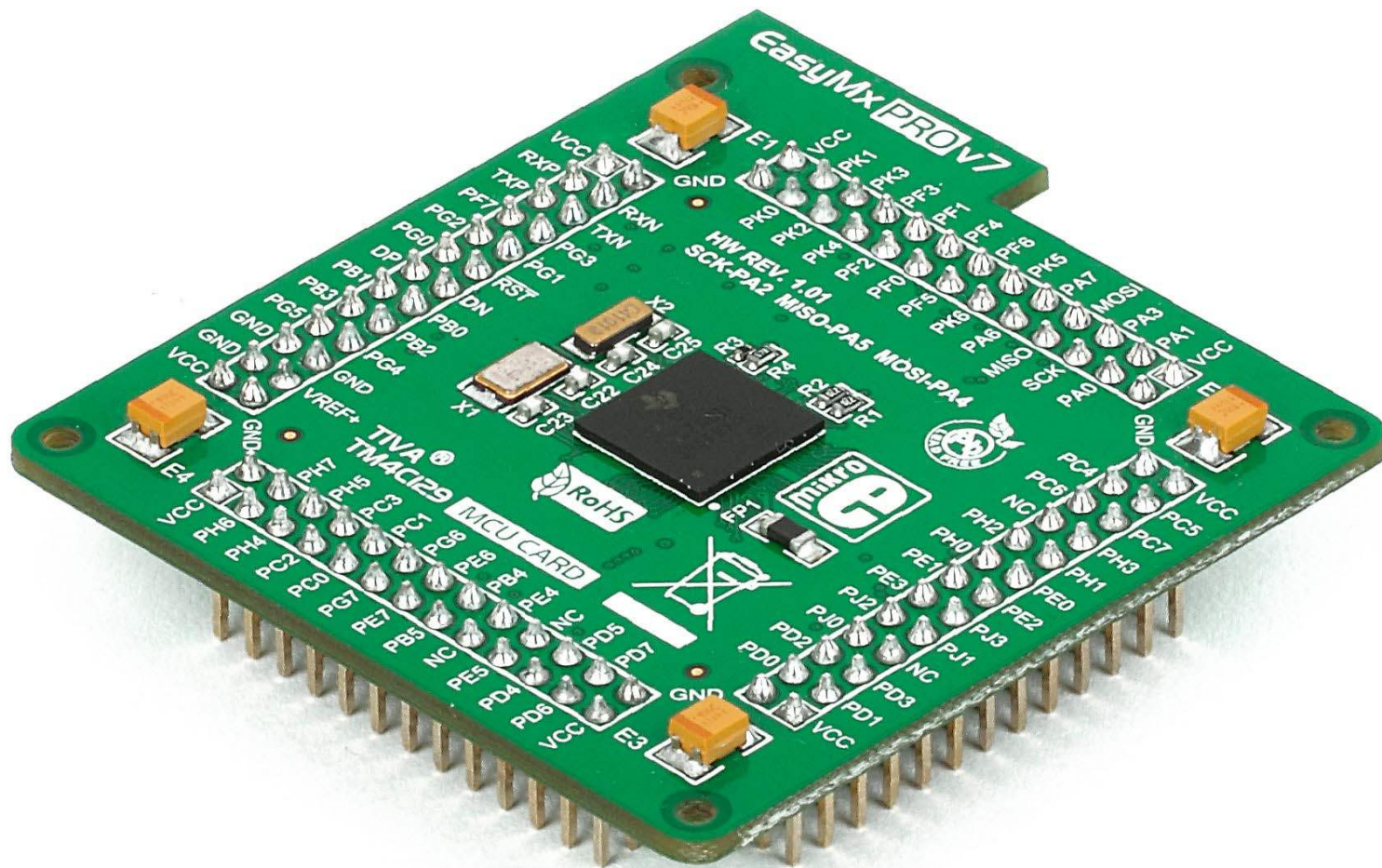

Card information

The **Default MCU card** that comes with the EasyMx PRO™ v7 package is shown on **Figure 1**. It contains **TM4C129XNCZAD** microcontroller which is loaded with on-chip modules and is a great choice for both beginners and professionals. After testing and building the final program, this card can also be taken out of the board socket and used in your final device.

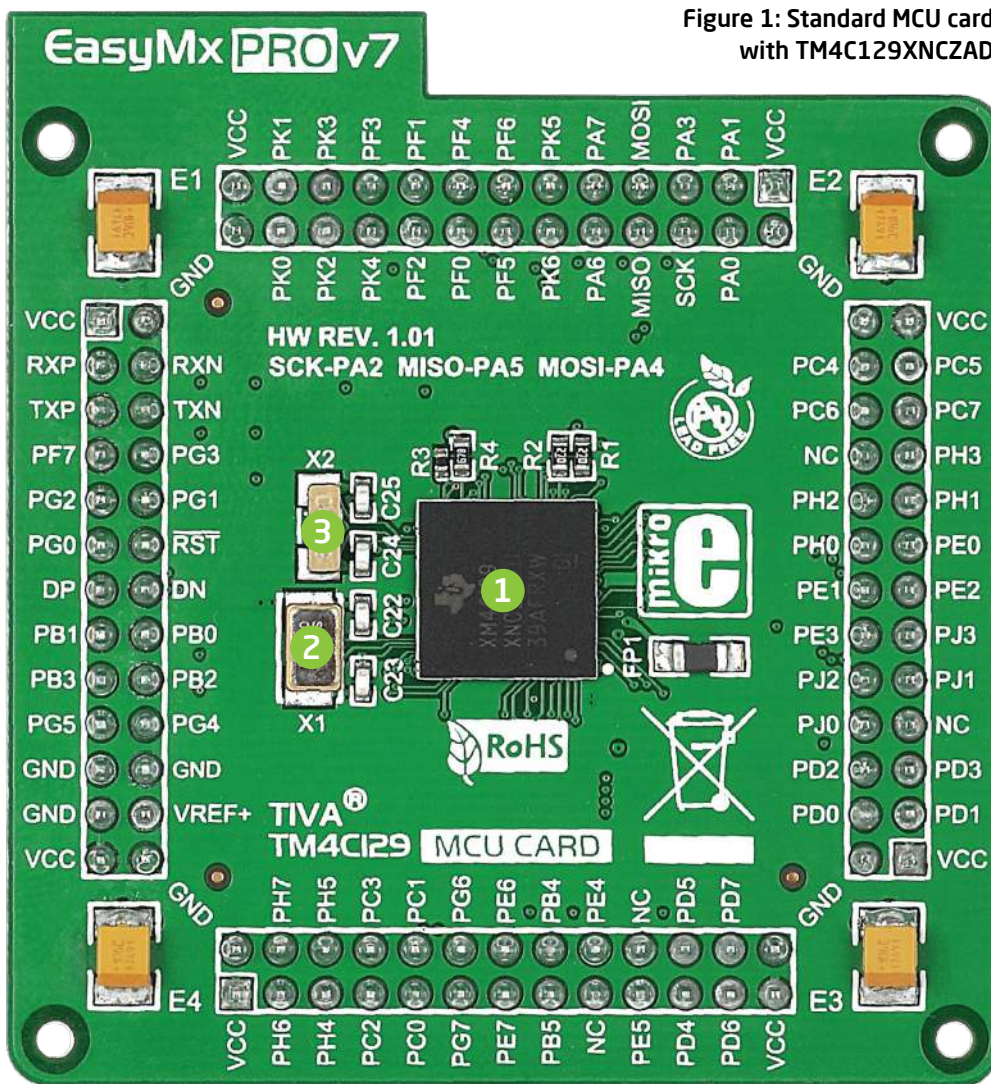

- 1** **TM4C129XNCZAD** is the default chip of EasyMx PRO™ v7 for Tiva™ C Series. It belongs to ARM® Cortex™-M4F family. It operates at **120MHz**, has **1024 KB** of Flash memory, **256 KB** of single-cycle System SRAM, integrated Ethernet controller with PHY, **USB 2.0** (OTG, Host, Device), 140 General purpose **I/O pins**, 7x16/32-bit **timers**, 2x12-bit **A/D** (24 channels), a 12-bit **D/A**, 8x**UARTs**, internal Real time clock (**RTC**), 10x**I2C**, 4x**SPI** and 2x**CAN** controllers. It has Serial wire debug (SWD) and JTAG interfaces for programming and debugging.
- 2** **25MHz crystal oscillator**. We carefully chose the most convenient crystal value that provides clock frequency which can be used directly, or with the PLL multipliers to create higher MCU clock value. MCU card also contains 32.768 kHz crystal oscillator which provides external clock for RTCC module.
- 3** **32.768-kHz external crystal oscillator** which provides external clock for the internal hibernation module.

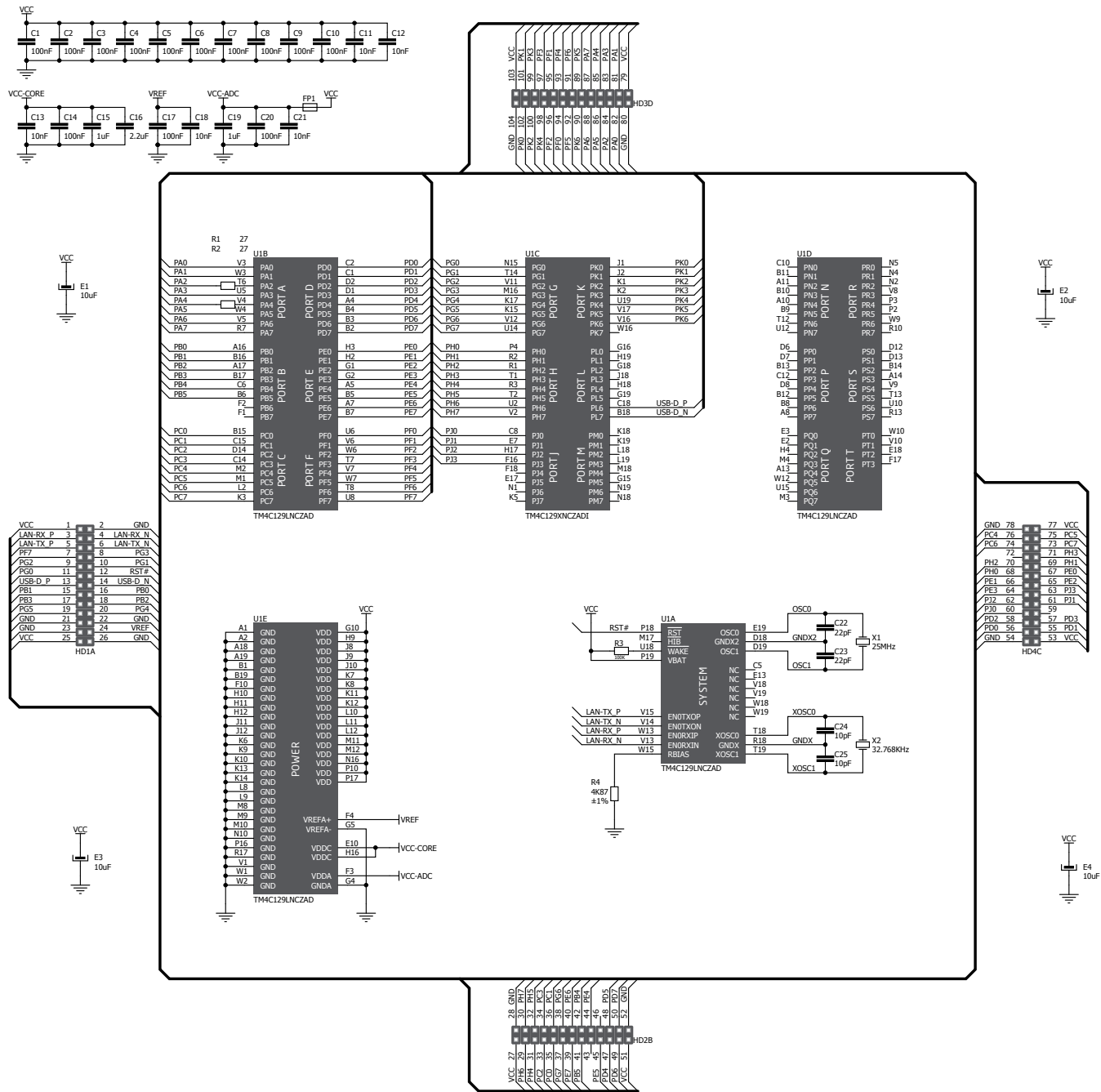

Figure 2: MCU card schematic

Card dimensions

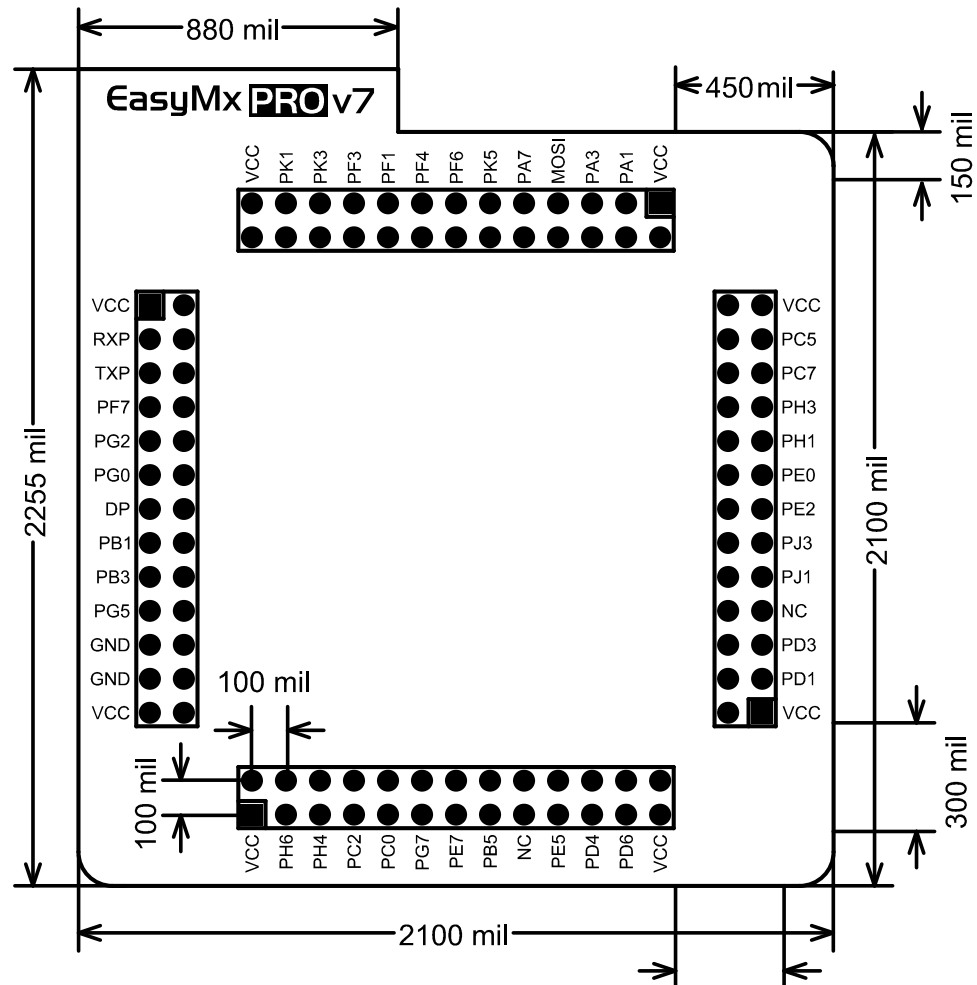
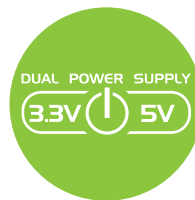
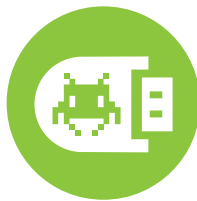

Figure 3: MCU card dimensions. Values are in mils.



If you want to learn more about our products, please visit our website at www.mikroe.com

If you are experiencing some problems with any of our products or just need additional information, please place your ticket at www.mikroe.com/support

If you have any questions, comments or business proposals,
do not hesitate to contact us at office@mikroe.com