

**CATALOG # 15EF1F**

|       |         |         |
|-------|---------|---------|
| ECD # | APPRVD. | DATE    |
|       | KAW     | 22NOV06 |

**SAFETY ORGANIZATIONS**

THIS FILTER HAS BEEN FORMALLY RECOGNIZED, CERTIFIED OR APPROVED BY THE LISTED AGENCY. THEREFORE, ALL TEST/REQUIREMENTS SPECIFIED IN THE LATEST REVISION OF THE FOLLOWING AGENCY STANDARDS HAVE BEEN MET:

- UL RECOGNIZED: UL 1283
- CSA CERTIFIED: CSA 22.2, # 8
- VOE APPROVED: EN 133200

**OPERATING SPECIFICATIONS**

LINE CURRENT/VOLTAGE: 15 AMP, 120/250VAC,  
10 AMP/40°C, 250VAC

LINE FREQUENCY: 50-60Hz

MAXIMUM LEAKAGE CURRENT,  
EACH LINE TO GROUND: 0.21mA @ 120V, 60Hz  
0.37mA @ 250V, 50Hz

OPERATING AMBIENT TEMP. RANGE: -10°C TO +40°C @ RATED CURRENT, I<sub>r</sub>.

IN AN AMBIENT, T<sub>0</sub>, HIGHER THAN 40°C, THE MAXIMUM OPERATING CURRENT, I<sub>0</sub>, IS AS FOLLOWS:

$$I_0 = I_r \sqrt{\frac{100 - T_0}{60}}$$

**RELIABILITY SPECIFICATIONS:**

STORAGE TEMPERATURE: -40°C TO +85°C  
HUMIDITY: 21 DAYS @ 40°C 95% RH.  
CURRENT OVERLOAD TEST: 6 TIMES I<sub>r</sub> FOR 8 SECONDS

**TEST SPECIFICATIONS:**

INDUCTANCE: 0.27mH NOMINAL  
CAPACITANCE: (MEASURED @ 1KHz, 0.250VAC MAX., 25°C±1°C)  
LINE TO GROUND: 0.0054µF ±20%  
LINE TO LINE: 0.0484µF ±20%  
DISCHARGE RESISTOR: 1.5MΩ  
L/G AND L/L I.R.:  
NO DISCHARGE RESISTOR: 6000MΩ (MIN.) @ 100VDC, 20°C AND 50% RH

**RECOMMENDED RECEIVING INSPECTION HIPOT:**

LINE TO GROUND: 1500VAC OR 2250VDC FOR 1 MINUTE  
LINE TO LINE: 1450VDC FOR 1 MINUTE

**FILTER APPROVAL:**

THE BEST WAY TO SELECT AND QUALIFY A FILTER IS FOR YOUR ENGINEERING TO TEST THE UNIT IN YOUR EQUIPMENT.

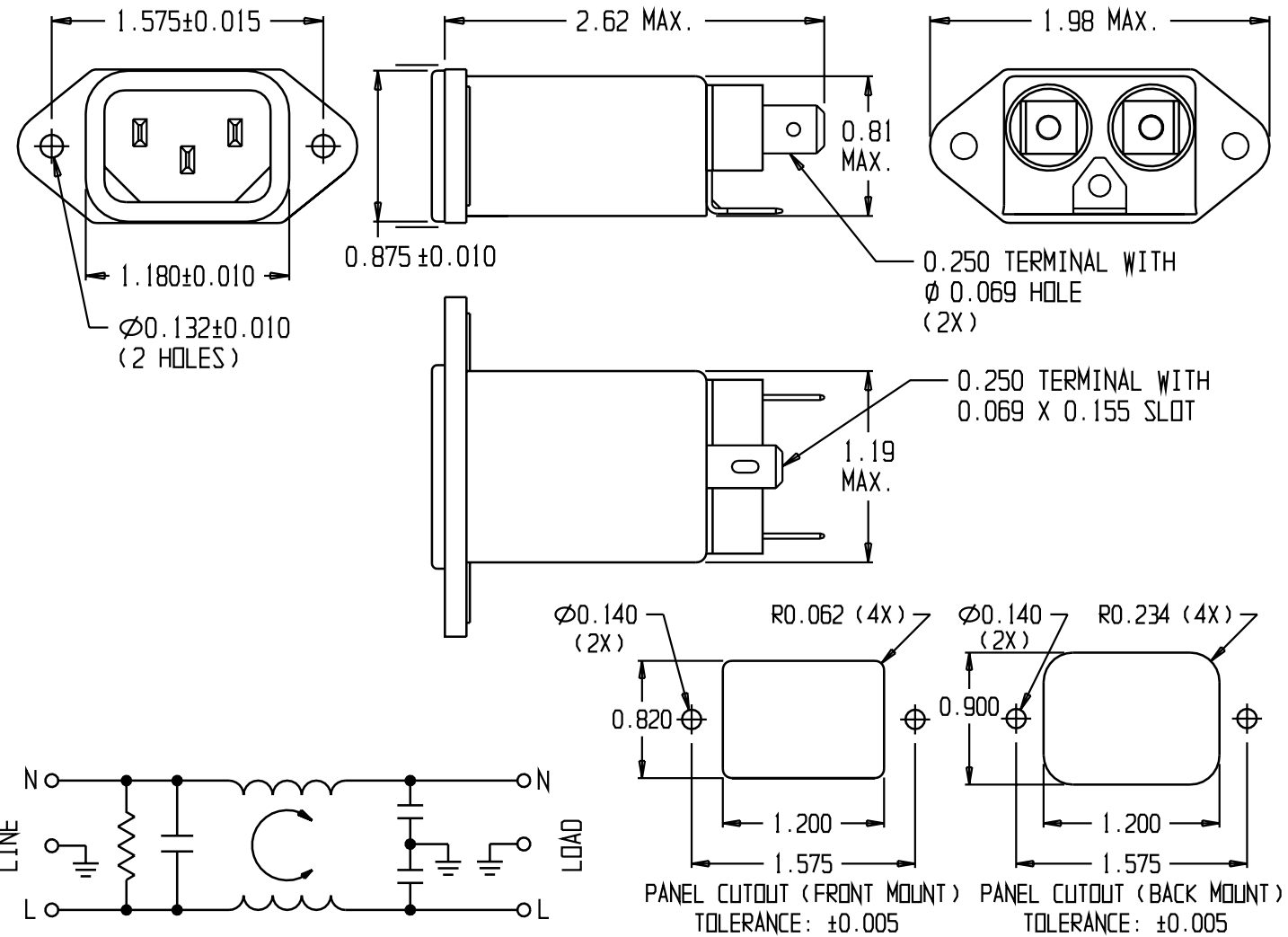

**50Ω- 50Ω (MINIMUM) INSERTION LOSS**

| FREQUENCY MHz | 0.150 | 0.50 | 1.0 | 5.0 | 10 | 20 | 30 |  |  |  |  |
|---------------|-------|------|-----|-----|----|----|----|--|--|--|--|
| COMMON dB     | -     | 6    | 12  | 20  | 25 | 28 | 25 |  |  |  |  |
| DIFF. dB      |       | 6    | 12  | 15  | 40 | 40 | 45 |  |  |  |  |

THIRD ANGLE PROJECTION

UNLESS OTHERWISE SPECIFIED, TOLERANCE TO BE ±.025 MATERIAL & FINISH: AS SUPPLIED

This document is proprietary to CORCOM INC. and is not to be reproduced nor used for manufacturing purposes except on CORCOM'S prior written consent.

**tyco** Electronics **corcom**  
620 S. BUTTERFIELD ROAD MUNDLEIGH IL 60060

**CUSTOMER DRAWING 15EF1F**

|                   |            |               |             |      |
|-------------------|------------|---------------|-------------|------|
| TYCO: 0-6609015-9 | SCALE: NTS | DATE: 23APR97 | CATALOG NO. | REV. |
| DRW. BY: JF       | ORIG: KAW  |               | 15EF1F      | B    |