

Proper use guidelines

Cumulative trauma disorders can result from the prolonged use of manually powered hand tools. Hand tools are intended for occasional use and low-volume applications. A wide selection of powered application equipment is available for extended-use production operations.

Figure 1: Heavy Head Hand Tools 59239-4, 59239-8, 59287-2, and 525692

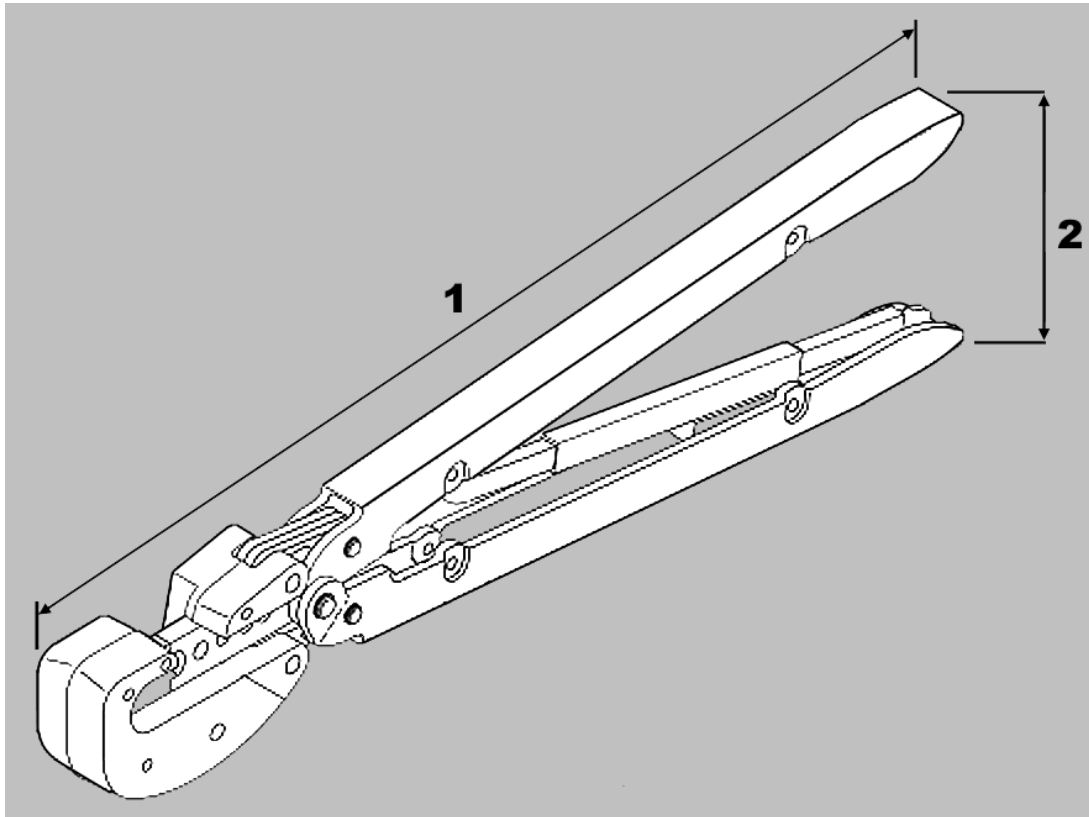

- 1** 304.8 [12.00] approximate
- 2** 76.2 [3.00] approximate

1 Introduction

Heavy Head Hand Tools (HHHT) 525692, 59239-4, 59239-8, and 59287-2 are the tool and die set shown in Figure 1. These tools are designed to crimp the product listed in Table 1 onto the wire also listed.

For other tools accompanied by this instruction sheet, follow the instructions for the tool used to crimp the same wire size.



NOTE

Dimensions in this instruction sheet are in millimeters with [inches in brackets]. Figures are for reference only and are not drawn to scale.

Read these instructions thoroughly before crimping connectors.

Table 1: Crimping specifications

Tool	Product		Wire			
	Type	Insulation color code	Type	Size (AWG)	Insulation diameter mm [in.]	
59239-4 59239-8 525692	PIDG™ vinyl and nylon terminal	Yellow	Solid or stranded copper	12-10	5.84-6.35 [.230-.250]	
	PIDG vinyl and nylon splice PLASTI-GRIP™ terminal	Yellow with black stripes		16-14 (heavy duty)		
	59239-4 59239-8 525692	PIDG insulation restring nylon terminal	Yellow with 3 yellow stripes	Stranded copper	12	2.41-5.08 [.095-.200]
			Yellow with 3 brown stripes		10	3.02-5.08 [.119-200]
	59239-4 59239-8 525692	PIDG radiation resistant terminal and splice	Natural with yellow stripe	Stranded copper	12-10	6.60 [.260] maximum
					16-14 (heavy duty)	
59239-4 59239-8 525692	Spare wire cap 328309	Yellow	Stranded copper	12-10	5.33 [.210] maximum	
59287-2	PIDG vinyl and nylon terminal	Yellow	Solid or stranded copper	12-10	6.99-7.62 [.275-.300]	
	PIDG vinyl and nylon splice PLASTI-GRIP terminal	Yellow with black stripe		16-14 (heavy duty)		

2 Description

Each tool consists of a head containing two stationary crimping dies (anvils), two movable crimping dies (indenters), a locator, an insulation crimping adjustment pin, and handles with a ratchet. See Figure 2.

Figure 2: Tool components

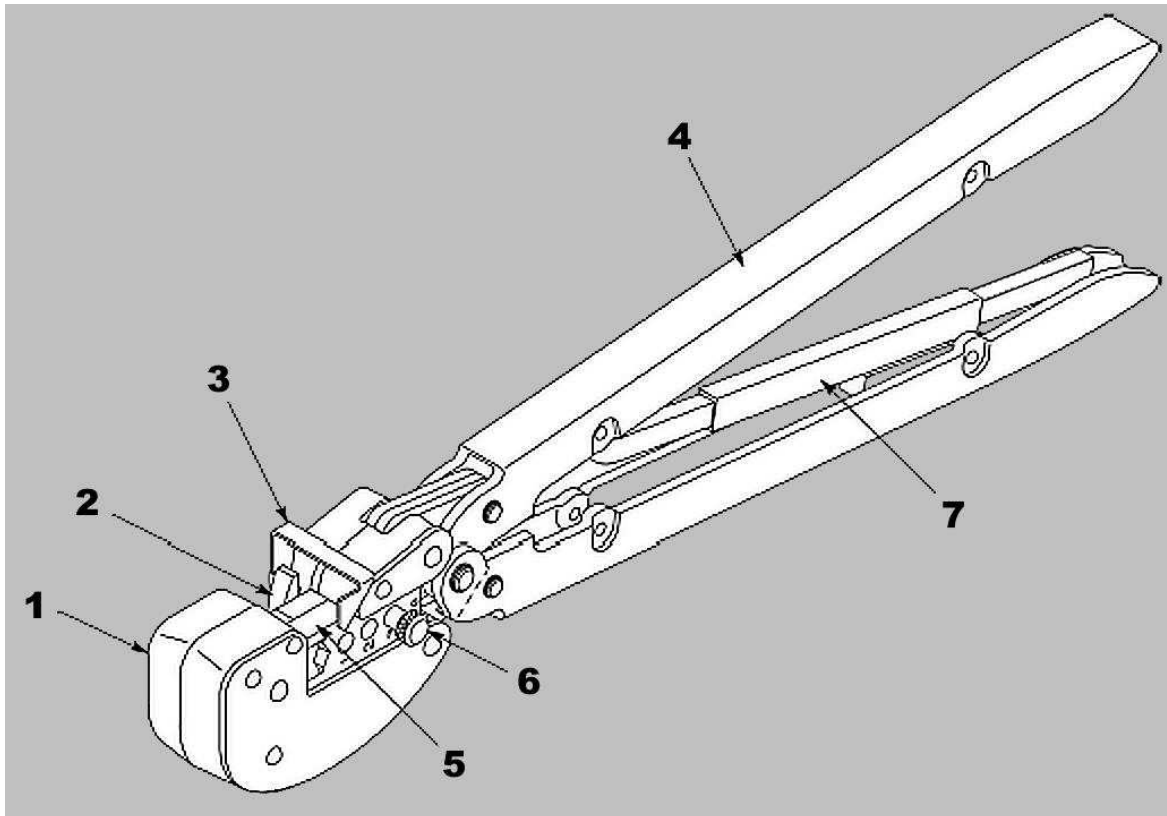

- | | |
|--------------------------------------------|---------------------------------------------|
| 1 Head | 5 Movable crimping dies (indenters) |
| 2 Stationary crimping dies (anvils) | 6 Insulation crimping adjustment pin |
| 3 Locator | 7 Ratchet |
| 4 Handle | |

These tools are members of the CERTI-CRIMP™ hand crimping tool family. The ratchet on these tools ensures full crimping of the product. After it is engaged, the ratchet does not release until the handles have been **fully** closed.

When closed, the crimping dies form a crimping chamber with two sections: an insulation barrel section and a wire barrel section. The insulation barrel section crimps the insulation barrel of the product onto the wire insulation. Simultaneously, the wire barrel section crimps the wire barrel of the product onto the wire conductors.

The crimping dies bottom before the ratchet releases. This design ensures maximum electrical and tensile performance of the crimp. **Do not** re-adjust the ratchet.

The locator positions the product in the crimping chamber. The insulation crimping adjustment pin is used to regulate the height of the insulation crimp.

Tool handles are colored yellow to correspond to the color code of the product. Each tool produces a dot code (one dot) on the crimp to correspond to the given wire size range. Refer to Figure 3.

Figure 3: Product color code

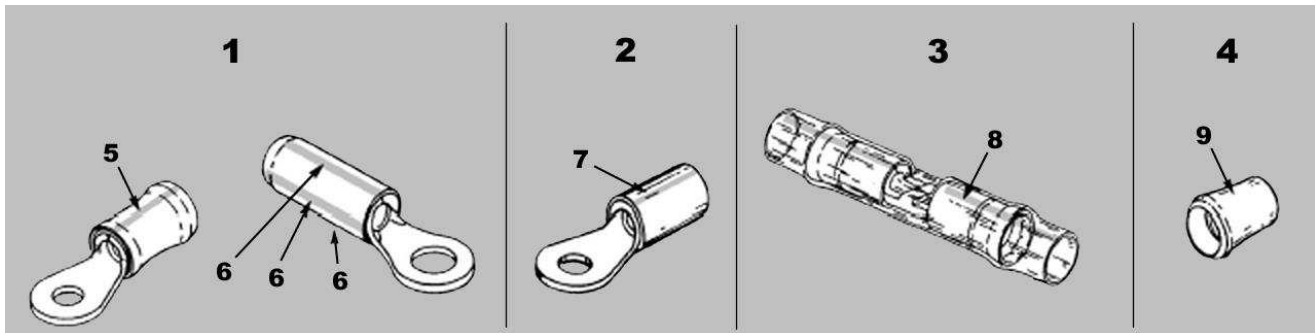

- 1** PIDG terminals
- 2** PLASTI-GRIP terminal
- 3** PIDG butt splice
- 4** Spare wire cap
- 5** Color stripe on heavy duty and radiation resistant
- 6** Three equally space color stripes on insulation restricting
- 7** Color stripe on heavy duty
- 8** Color stripe on radiation resistant
- 9** Color of insulation

3 Crimping

Make sure that the insulation color code of the product matches the color of the tool handles (see Figure 3).

3.1 Stripping the wire

Strip the wire within the dimensions listed in Table 2. **Do not** nick or damage the wire conductors.



CAUTION
Do not use wire with nicked or missing conductors.

Figure 4: Wire strip length

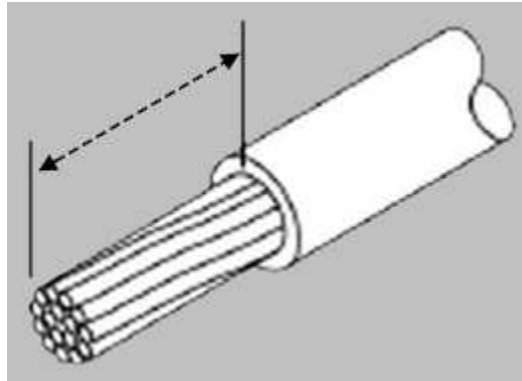
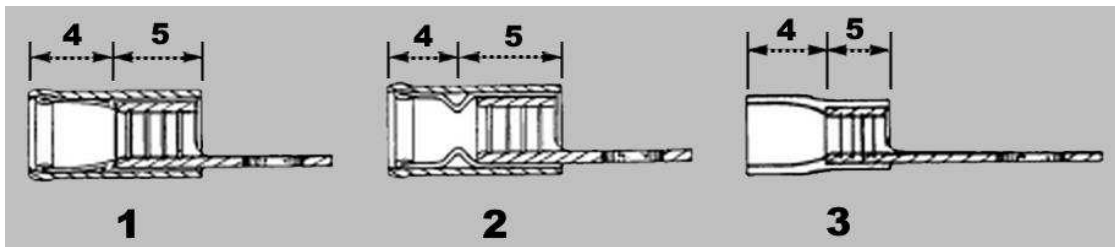

Table 2: Strip length by product

Product	Strip length
PIDG vinyl and nylon terminal PLASTI-GRIP terminal PIDG radiation resistant terminal	7.94-8.73 [.312-.344]
PIDG insulation restricting nylon terminal	9.65-10.4 [.380-.410]
PIDG vinyl and nylon splice PIDG radiation resistant splice Spare wire cap	8.64-9.65 [.340-.380]

3.2 Crimping a terminal

Figure 5: Terminal types



- 1** PIDG terminal
- 2** PIDG insulation-restricting terminal
- 3** PLASTI-GRIP terminal
- 4** Insulation barrel
- 5** Wire barrel

To crimp a terminal, complete the following steps.

1. Insert the insulation crimp adjustment pin in the proper position as described in section 4.
2. Open the crimping dies by closing the tool handles until the ratchet releases, then allow the handles to open **fully**.
3. Place the terminal in the crimping chamber so that the wire barrel butts against the locator (Figure 6).

Figure 6: Positioning the terminal

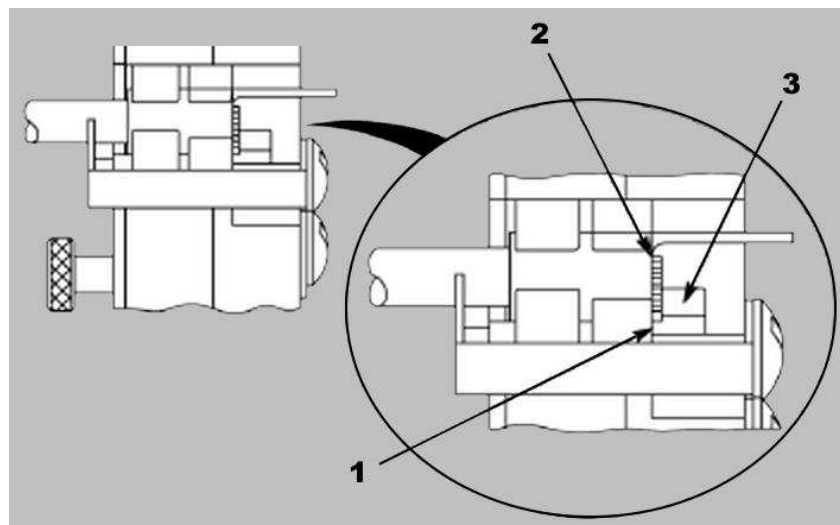

- 1** Wire barrel against locator
- 2** End of wire conductors against locator
- 3** Locator

4. Close the tool handles until the terminal is held firmly in place. **Do not** deform the terminal.
5. Insert a properly stripped wire into the terminal wire barrel until the end of the wire conductor(s) butts against the locator.
6. Complete the crimp by closing the tool handles until the ratchet releases.
7. Release the tool handles, allow the handles to open **fully**, and remove the crimped terminal.
8. Inspect the crimp as described in sections 4.1 and 4.3. Do not use terminals that fail to meet the required conditions.

3.3 Crimping a butt splice

Figure 7: Butt splice

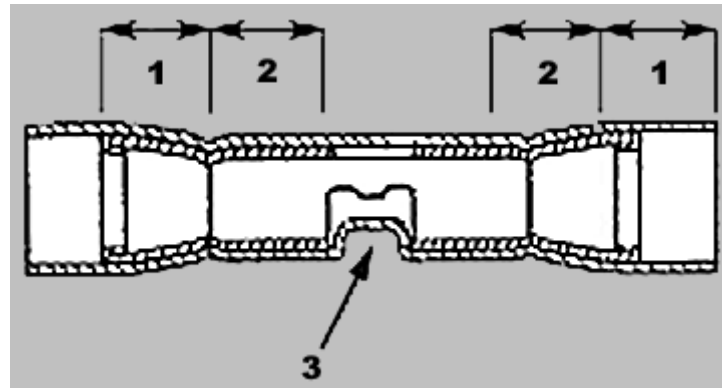

- 1 Insulation barrel
- 2 Wire barrel
- 3 Window indentation

To crimp a butt splice, complete the following steps.

1. Open the crimping dies by closing the tool handles until the ratchet releases, then allow the handles to open **fully**.
2. Depress the locator. Position the splice in the crimping chamber so that window indentation of the splice rests over the locator (Figure 8).

Figure 8: Positioning the butt splice

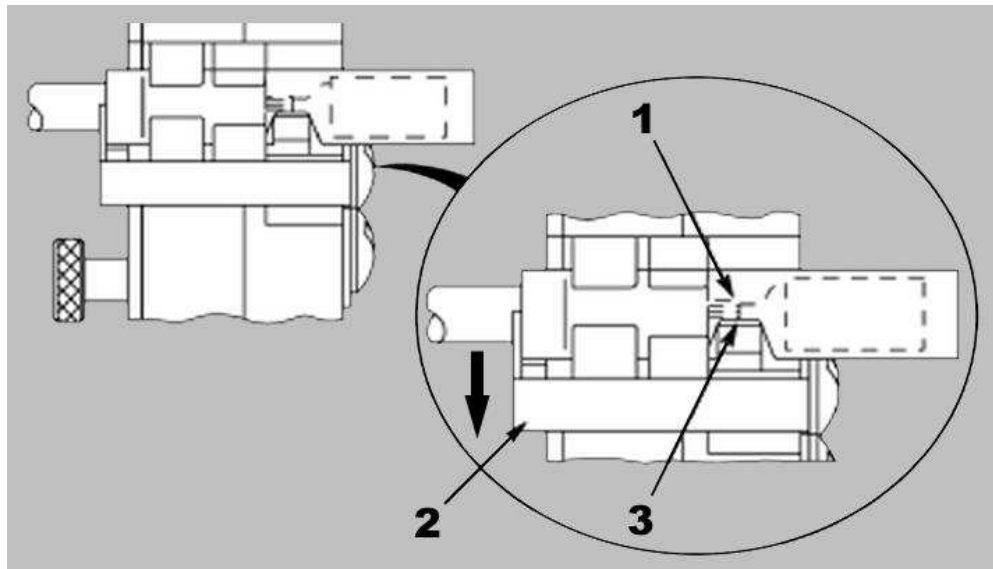

- 1 End of wire conductors against splice wire stop
- 2 Locator depressed
- 3 Splice window indentation over locator

3. Close the tool handles until the splice is held firmly in place. **Do not** deform the splice.
4. Insert a properly stripped wire into the wire barrel of the splice until the end of the wire conductor butts against the splice wire stop.
5. Complete the crimp by closing the tool handles until the ratchet releases.

6. Release the tool handles and allow the handles to open **fully**.
7. Remove the crimped splice.
8. Turn the splice around, depress the locator, and position the splice in the crimping chamber so that the window indent of the splice seats over the locator. Follow steps 3 through 6.
9. Inspect the crimp as described in section 4.2. Do not use splices that fail to meet the required conditions.

3.4 Crimping a spare wire cap

Figure 9: Wire barrel of spare wire cap

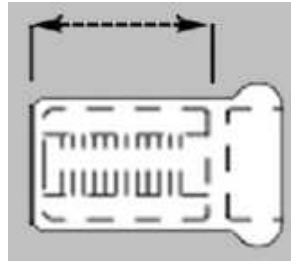

1. Place the tool insulation adjustment pins in the position 3.
2. Close the tool handles until the crimping dies partially close, but leave enough space for the spare wire cap to be inserted in the crimping chamber.
3. Depress the locator so that the end of the spare wire cap rests against the recessed surface of the locator (Figure 10).

Figure 10: Positioning the spare wire cap

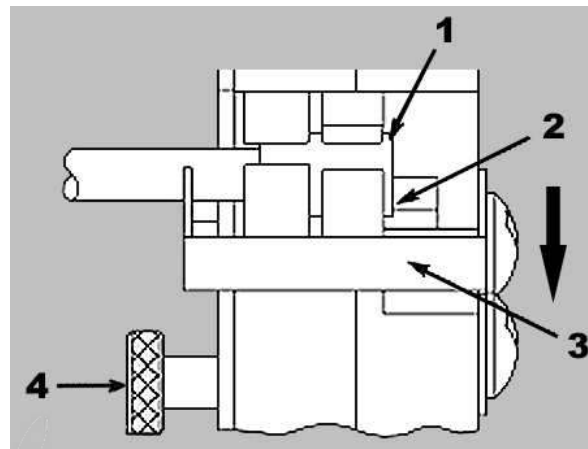

- 1** Wire conductors bottomed in spare wire cap
- 2** End of spare wire cap against recessed surface of locator
- 3** Locator depressed
- 4** Insulation pin in position 3

4. Close the tool handles until the spare wire cap is held firmly in place. **Do not** deform the spare wire cap.
5. Insert a properly stripped wire into the spare wire cap until the wire conductor(s) bottoms.
6. Hold the wire in position, and complete the crimp by closing the tool handles until the ratchet releases.
7. Release the tool handles, allow the handles to open **fully**, and remove the crimped spare wire cap.
8. Inspect the crimp as described in section 4.4. Do not use caps that fail to meet the required conditions.

4 Inspecting the crimp

4.1 PIDG or PLASTI-GRIP terminal

Inspect the crimp for the features shown in Figure 11. Do not use a terminal that has any of the features shown in Figure 12.

Figure 11: Features of a good crimp (terminal)

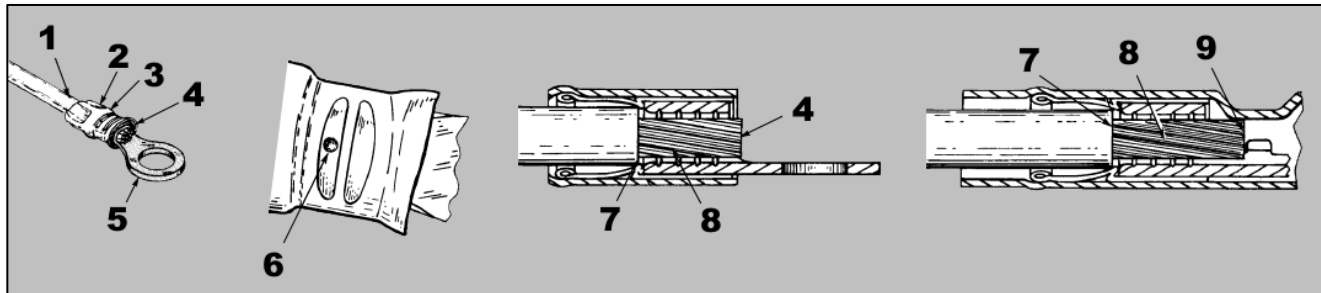

- 1 Insulation barrel is in firm contact with wire insulation
- 2 Correct color code, dot code, and tool combination
- 3 Crimp is centered on wire barrel
- 4 End of conductor is flush with (or extends beyond) end of terminal wire barrel
- 5 Wire size is within range stamped under terminal tongue
- 6 Dot code (one dot) is present
- 7 Wire insulation does not enter wire barrel
- 8 No nicked or missing conductor strands
- 9 End of conductor butts against wire stop

Figure 12: Features of a poor crimp (terminal)

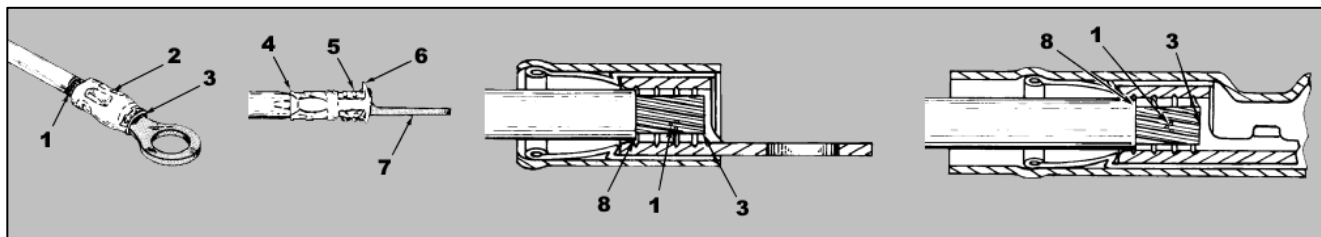

- 1 Nicked or missing conductor strands
- 2 Crimp not centered on wire barrel (terminal was not against locator)
- 3 End of conductor not flush with (or extending beyond) end of terminal wire barrel (check strip length)
- 4 Wire insulation is extruded (insulation crimp is too tight)
- 5 Wrong color code and dot code combination
- 6 Excess flash or extruded insulation (wrong tool or terminal, or damaged dies)
- 7 Wire range stamped here
- 8 Wire insulation enters wire barrel

4.2 PIDG butt splice

For a PIDG butt splice, inspect the crimp for the features shown in Figure 13. Do not use a splice that has any of the features of a poor crimp.

Figure 13: Inspecting a butt splice

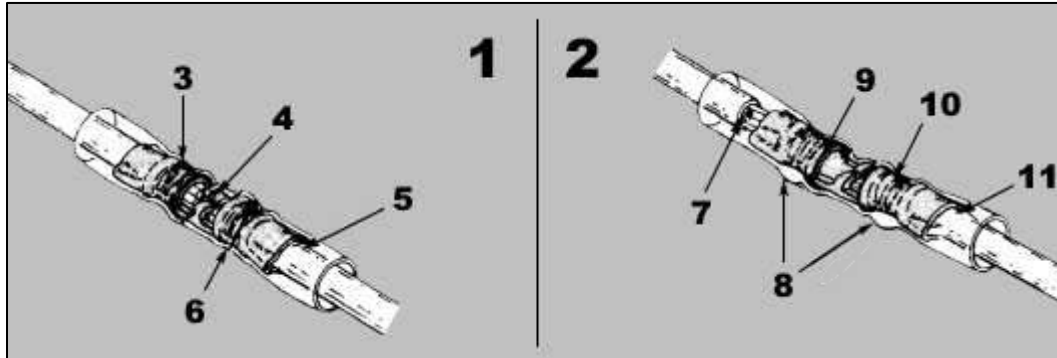

- 1** Features of a good crimp
- 2** Features of a poor crimp
- 3** Crimp is centered on wire barrel
- 4** End of conductor butts against wire stop
- 5** Insulation barrel is in firm contact with wire insulation
- 6** Correct color code, dot code, and tool combination
- 7** Nicked or missing conductor strands
- 8** Excess flash or extruded insulation (wrong tool or splice, or damaged dies)
- 9** End of conductor not flush with (or extending beyond) end of terminal wire barrel (check strip length)
- 10** Wrong color code and dot code combination
- 11** Wire insulation is extruded (insulation crimp is too tight)

4.3 PIDG insulation-restricting terminal

Inspect the crimp for the features shown in Figure 14. Do not use a terminal that has any of the features of a poor crimp.

Figure 14: Inspecting a PIDG insulation-restricting terminal

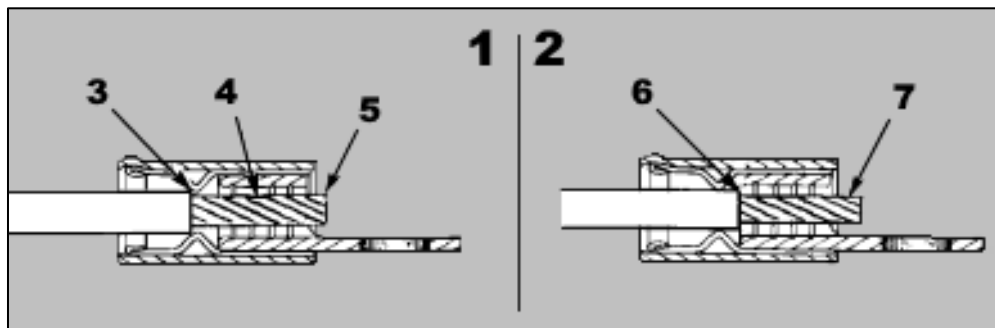

- 1** Features of a good crimp
- 2** Features of a poor crimp
- 3** Wire insulation does not enter wire barrel
- 4** No nicked or missing conductor strands
- 5** Conductor can extend slightly beyond wire barrel
- 6** Wire insulation enters wire barrel
- 7** Nicked or missing conductor strands

4.4 Spare wire cap

Inspect the crimp for the features shown in Figure 15. Do not use a cap that has any of the features of a poor crimp.

Figure 15: Inspecting a spare wire cap

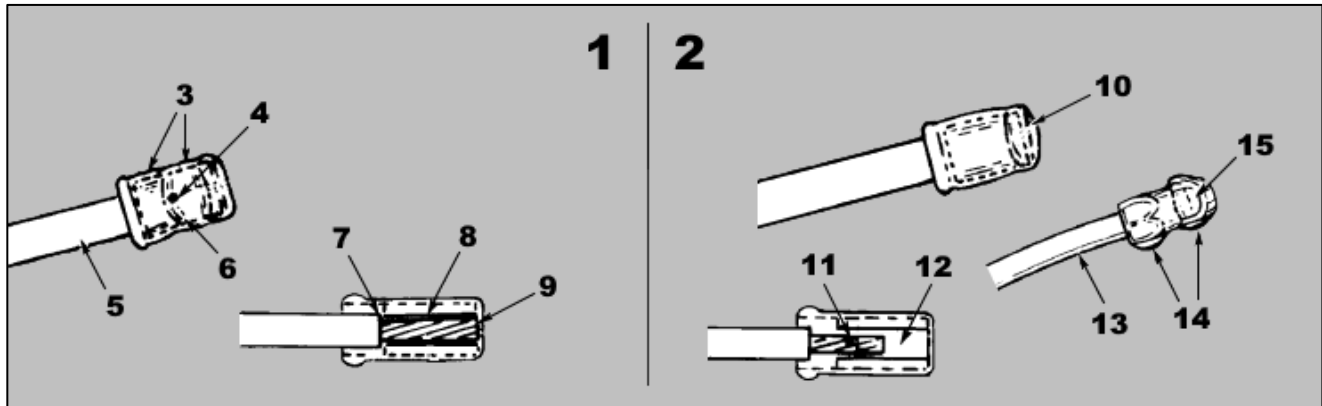

- 1** Features of a good crimp
- 2** Features of a poor crimp
- 3** No flash or extruded insulation
- 4** Correct color code, dot code, and tool combination
- 5** Correct wire size
- 6** Full width of crimp is over wire barrel of cap
- 7** Wire insulation does not enter wire barrel
- 8** No nicked or missing conductor strands
- 9** End of conductor is bottomed in cap
- 10** Part of crimp is off end of wire barrel (cap was not bottomed in *recess* of locator)
- 11** Nicked or missing conductor strands
- 12** End of conductor is not bottomed in cap
- 13** Wrong wire size
- 14** Excess flash or extruded insulation (wrong tool or damaged dies)
- 15** Wrong color code and dot code combination

5 Adjusting the insulation crimp

The insulation crimping adjustment pin (Figure 16) has three positions:

1. Tight
2. Medium
3. Loose

Figure 16: Insulation crimping adjustment pin

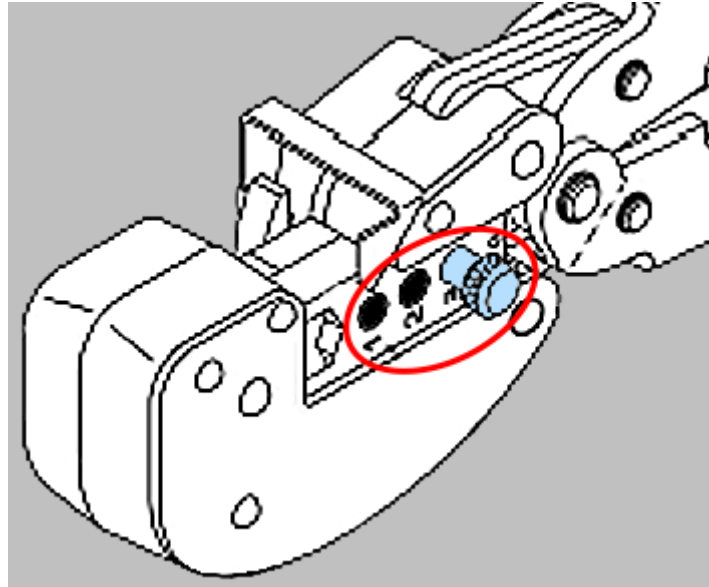

To adjust the grip resulting from the crimp of the insulation barrel, proceed as follows.

5.1 PIDG terminal and splice

PIDG terminals and splices feature a wire insulation grip.

1. Insert the insulation crimp adjustment pin into position 3. Refer to Figure 1.
2. Place the terminal or splice into the crimping chamber as described in section 3.
3. Insert an unstripped wire into only the insulation barrel of the terminal or splice.
4. Close the tool handles until the ratchet releases.
5. Release the tool handles, and allow the handles to open fully. Remove the crimped terminal or splice.
6. Check the insulation barrel crimp by bending the wire back and forth once. The terminal or splice should retain its grip on the wire insulation. If it does not, insert each insulation crimp adjustment pin into the next position (position 2).
7. Repeat steps 2 through 6 until the correct insulation barrel grip is attained. Do not use a tighter position than is necessary.

5.2 PLASTI-GRIP terminal

PLASTI-GRIP terminals and splices feature a wire insulation support only. Ideally, the terminal or splice insulation should be in contact with the wire insulation.

Insert the insulation crimp adjustment pin into the appropriate position (see Table 3).

Table 3: Positions for the insulation crimp adjustment pins

Insulation diameter of wire	Pin position
Large	1
Medium	2
Small	3

6 Maintenance and inspection

6.1 Daily maintenance

Make each operator of the power unit aware of, and responsible for, the following daily maintenance requirements:

- Remove dust, moisture, and other contaminants with a clean, soft brush or soft, lint-free cloth. **Do not** use objects that could damage the dies or tool.
- Ensure that the retaining pins are in place and secured with retaining rings.
- Protect all pins, pivot points, and bearing surfaces with a **thin** coat of any good SAE 20 motor oil. **Do not** oil excessively.
- When the tool is not in use, keep the handles closed to prevent objects from becoming lodged in the dies.
- Remove all lubrication and accumulated film by immersing the tool (with handles partially closed) in a suitable commercial degreaser.
- Store the tool in a clean, dry area.

6.2 Lubrication

Lubricate all pins, pivot points, and bearing surfaces with SAE 20 motor oil as indicated in Table 4.

Table 4: Lubrication schedule

How tool is used	When to lubricate
In daily production	Daily
Daily (occasional)	Weekly
Weekly	Monthly

Wipe excess oil from the tool, particularly from the crimping area. Oil transferred from the crimping area onto terminations can affect the electrical characteristics of an application.

6.3 Periodic inspection

Regular inspections should be performed by quality control personnel. A record of scheduled inspections should remain with the dies or be supplied to personnel responsible for the dies. Recommendations call for at least one inspection per month. Base your inspection frequency on the amount of use, ambient working conditions, operator training and skill, and established company standards. Perform the inspection as follows:

- Close the tool handles until the ratchet releases and then allow them to open freely. If they do not open quickly and fully, the spring is defective and must be replaced. Refer to section 7, Replacement and repair.

**NOTE**

Some tools do not have handle return springs. This inspection does not apply to those tools.

- Inspect the tool and dies on a regular basis to ensure that they are not worn or damaged.
- Make sure that the die retaining screws are properly secured.
- Inspect the crimping chambers of the die assembly for flattened, chipped, cracked, worn, or broken areas.
- If damage or abnormal wear is evident, return the tool for evaluation and repair. Refer to section 7, Replacement and repair.

6.4 Gaging the crimping chamber

This inspection requires the use of plug gages conforming to the dimensions listed in Table 5. TE Connectivity does not manufacture or market these gages. For additional information regarding the use of plug gages, refer to instruction sheet [408-7424](#).

Figure 17: Recommended plug gage design for wire barrel section of crimping chamber

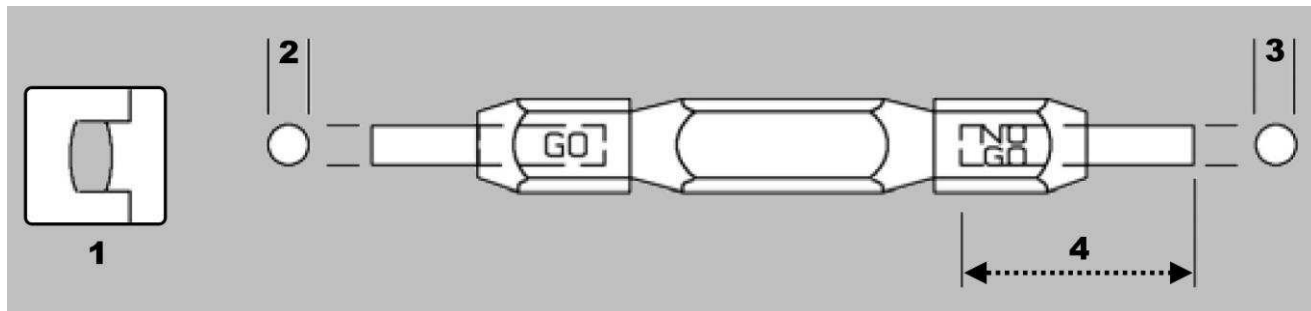

- 1 Die closure configuration
- 2 GO element dimension
- 3 NO GO element dimension
- 4 50.8 [2.0] minimum (typical)

Figure 18: Recommended plug gage design for insulation barrel section of crimping chamber

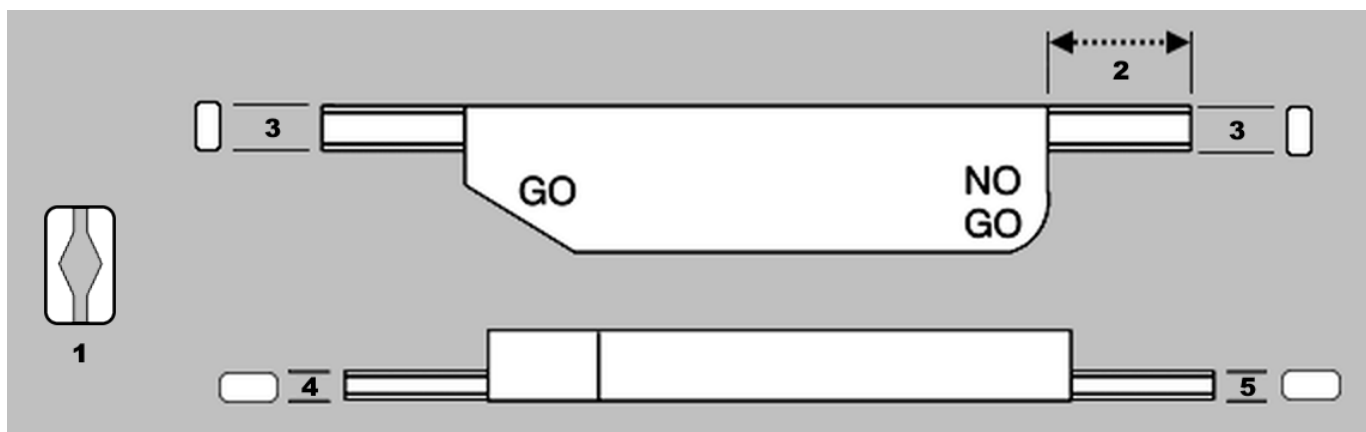

- 1 Die closure configuration
- 2 6.35 [.250] minimum (typical)
- 3 4.34 ± 0.13 [.171 \pm .005]
- 4 GO element dimension
- 5 NO GO element dimension

Table 5: Gage element dimensions

Section of crimping chamber	GO element	NO GO element
Wire barrel	4.293-4.300 [.1690-.1693]	4.442-4.445 [.1749-.1750]
Insulation barrel	1.626-1.633 [.0640-.0643]	2.131-2.134 [.0839-.0840]

To gage the crimping chamber, proceed as follows:



NOTE

If gaging the crimping chamber is not required, inspect the die closure using an alternate procedure (section 5, **Adjusting the insulation crimp**, and section 6.3, **Periodic inspection**).

1. Remove traces of oil or dirt from the crimping chamber and plug gage.
2. Insert each insulation crimp adjustment pin into position 1. (See Figure 16).
3. Close the tool handles until the crimping dies bottom, and hold in this position. **Do not** force beyond initial contact.
4. Press and hold the locator down.
5. Gage the wire barrel section of the crimping chamber by gently inserting the GO and NO GO elements as shown in Figure 19. Do not use force.
 - The GO element must pass completely through the crimping chamber.
 - The NO GO element can begin entry, but must not pass through the crimping chamber

Figure 19: Gaging the wire barrel section of the crimping chamber

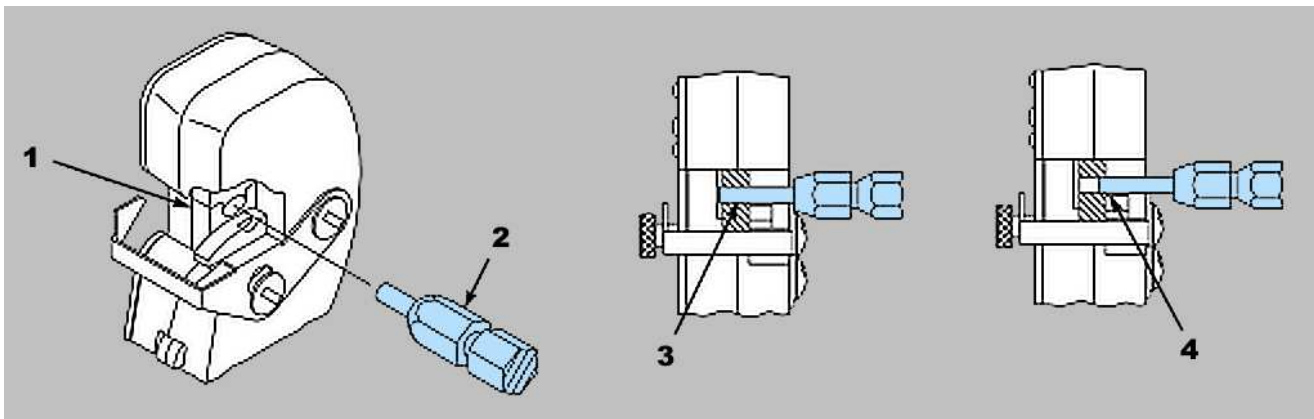

- 1 Crimping dies bottomed, but not under pressure
- 2 Plug gage
- 3 GO element must pass completely through crimping chamber
- 4 NO GO element can start entry, but must not pass completely through crimping chamber

6. Gage the insulation barrel section of the crimping chamber by gently inserting the GO and NO GO elements as shown in Figure 20.
 - The GO element must pass through the length of the section, but will stop against the wire barrel section.
 - The NO GO element can begin entry, but must not pass through the crimping chamber

Figure 20: Gaging the insulation barrel section of the crimping chamber

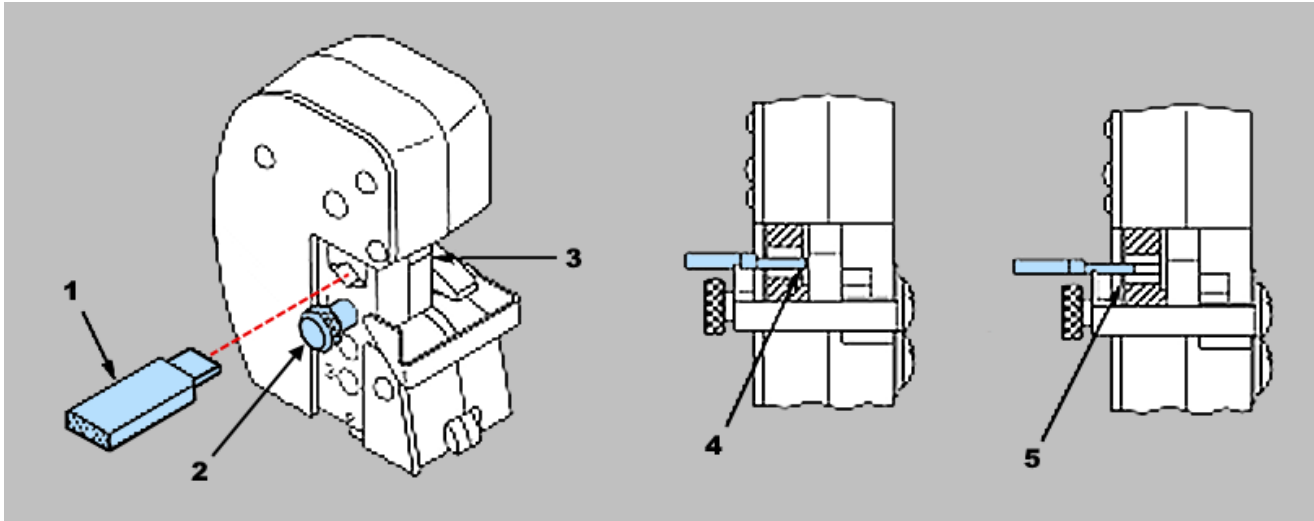

- 1 Plug gage
 - 2 Insulation crimp adjustment pin in position 1
 - 3 Crimping dies bottomed, but not under pressure
 - 4 GO element must pass completely through crimping chamber
 - 5 NO GO element can start entry, but must not pass completely through crimping chamber
- If the crimping chamber conforms to the gage inspection, the tool is considered dimensionally correct. Lubricate it with a **thin** coat of any good SAE 20 motor oil.
 - If not, return the tool for evaluation and repair. See section 6, **Replacement and repair**.

6.5 Inspecting the ratchet

Check the ratchet to ensure that the ratchet does not release prematurely, allowing the dies to open before they have fully bottomed. Proceed as follows:

1. Remove traces of oil or dirt from the bottoming surfaces of the dies.
 2. Obtain a 0.025 mm [.001 in.] shim that is suitable for checking the clearance between the bottoming surfaces of the dies.
 3. Select a terminal or splice and maximum size wire for the terminal or splice.
 4. Position the terminal or splice in the crimping chamber as described in section 3. Holding the wire in place, squeeze the tool handles together until the ratchet releases. Hold the tool handles in this position, maintaining just enough pressure to keep the dies closed.
- Check the clearance between the bottoming surfaces of the dies. If the clearance is 0.025 mm [.001 in.] or less, the ratchet is satisfactory. If clearance exceeds 0.025 mm [.001 in.], the ratchet is out of adjustment and must be repaired. See section 6, **Replacement and repair**.

7 Replacement and repair

The parts listed in Table 6 are customer-replaceable. Stock and control a complete inventory to prevent lost time when replacement of parts is necessary.

Figure 21: Replacement parts

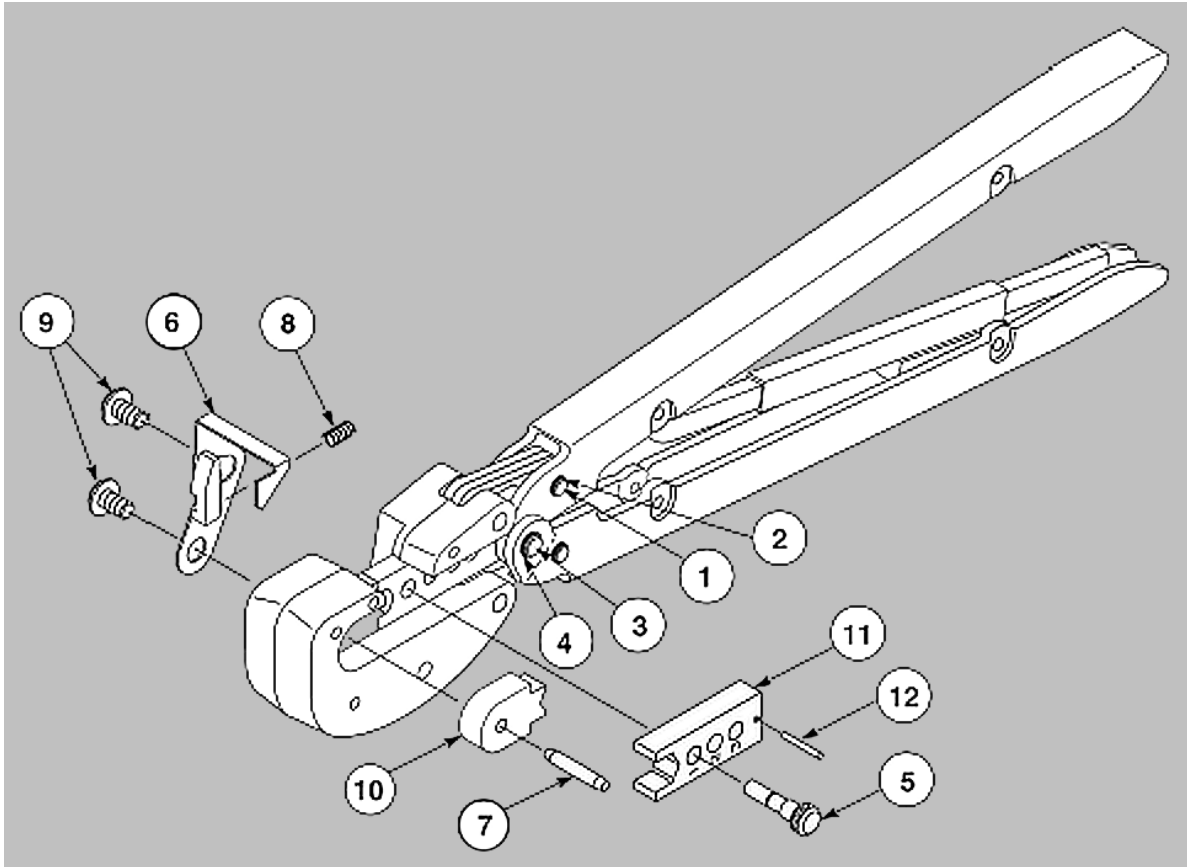

Table 6: Replacement part numbers

Item	59239-4 59239-8	59287-2	525692	Description	Quantity per tool
1	300388			Retaining pin	2
2	21045-3	525108		Retaining ring	4
3	300389			Retaining pin	1
4	21045-6			Retaining ring	2
5	303848-2			Adjustment pin assembly	1
6	306110-9	306110-4	306110-9	Stop locator	1
7	5-21028-7			Pin	1
8	7-59683-6			Spring	1
9	6-306131-4			Screw	2
10	306106-2	45891-8	306106-2	Stationary die (insulation)	1
11	306107-2	45888-7	306107-2	Moving die (insulation)	1
12	21028-4	21028-5	21028-4	Pin	1

Parts not listed in Table 6 should be replaced by TE Connectivity to ensure quality and reliability.

Order replacement parts through your TE representative. You can also order parts by any of the following methods:

- Go to TE.com and click the **Shop TE** link at the top of the page.
- Call 800-522-6752.
- Write to:

CUSTOMER SERVICE (038-035)
TE CONNECTIVITY CORPORATION
PO BOX 3608
HARRISBURG PA 17105-3608

For customer repair services, call 800-522-6752.

8 Revision summary

Since the last revision of this document, the following changes were made:

- Corrected Figure 18