

ON Semiconductor

Is Now

onsemi™

To learn more about onsemi™, please visit our website at
www.onsemi.com

onsemi and **onsemi** and other names, marks, and brands are registered and/or common law trademarks of Semiconductor Components Industries, LLC dba "**onsemi**" or its affiliates and/or subsidiaries in the United States and/or other countries. **onsemi** owns the rights to a number of patents, trademarks, copyrights, trade secrets, and other intellectual property. A listing of **onsemi** product/patent coverage may be accessed at www.onsemi.com/site/pdf/Patent-Marking.pdf. **onsemi** reserves the right to make changes at any time to any products or information herein, without notice. The information herein is provided "as-is" and **onsemi** makes no warranty, representation or guarantee regarding the accuracy of the information, product features, availability, functionality, or suitability of its products for any particular purpose, nor does **onsemi** assume any liability arising out of the application or use of any product or circuit, and specifically disclaims any and all liability, including without limitation special, consequential or incidental damages. Buyer is responsible for its products and applications using **onsemi** products, including compliance with all laws, regulations and safety requirements or standards, regardless of any support or applications information provided by **onsemi**. "Typical" parameters which may be provided in **onsemi** data sheets and/or specifications can and do vary in different applications and actual performance may vary over time. All operating parameters, including "Typicals" must be validated for each customer application by customer's technical experts. **onsemi** does not convey any license under any of its intellectual property rights nor the rights of others. **onsemi** products are not designed, intended, or authorized for use as a critical component in life support systems or any FDA Class 3 medical devices or medical devices with a same or similar classification in a foreign jurisdiction or any devices intended for implantation in the human body. Should Buyer purchase or use **onsemi** products for any such unintended or unauthorized application, Buyer shall indemnify and hold **onsemi** and its officers, employees, subsidiaries, affiliates, and distributors harmless against all claims, costs, damages, and expenses, and reasonable attorney fees arising out of, directly or indirectly, any claim of personal injury or death associated with such unintended or unauthorized use, even if such claim alleges that **onsemi** was negligent regarding the design or manufacture of the part. **onsemi** is an Equal Opportunity/Affirmative Action Employer. This literature is subject to all applicable copyright laws and is not for resale in any manner. Other names and brands may be claimed as the property of others.

**User Guide for
FEBFAN3240_001NDA
FEBFAN3241_001NDA
Evaluation Boards**

**FAN324x Smart Dual-Coil Relay Driver
Evaluation Board**

**Featured Fairchild Products:
FAN3240, FAN3241
(FAN324x)**

*Direct questions or comments
about this evaluation board to:
“Worldwide Direct Support”*

Fairchild Semiconductor.com

Table of Contents

1. Overview of the Evaluation Board.....	3
2. Photographs.....	4
3. Key Features of FAN324x.....	5
3.1. Applications.....	5
4. Specifications.....	6
5. Test Setup.....	6
6. Schematic.....	7
7. Bill of Materials (BOM).....	8
8. Test Results: FAN3240.....	9
8.1. Input Qualification.....	9
8.2. Operation with Qualified Inputs.....	10
8.3. Operation with Input Permanently HIGH.....	11
8.4. Enable / Disable Functionality.....	12
8.5. Noise on the Inactive Input.....	13
8.6. XOR Protection.....	14
9. Test Results: FAN3241.....	15
9.1. Input Qualification.....	15
9.2. Operation with Qualified Inputs.....	16
9.3. Operation with Input Permanently HIGH.....	17
9.4. Enable / Disable Functionality.....	18
9.5. Noise on the Inactive Input.....	19
9.6. XOR Protection.....	20
10. References.....	21
11. Ordering Information.....	21
12. Revision History.....	21

This user guide supports the FAN324x evaluation board for dual-coil relay-driving circuits. It should be used in conjunction with the [FAN3240/41 datasheet](#), which includes a section on the theory of product operation as well as the application information.

1. Overview of the Evaluation Board

The FAN324x “smart” dual-coil relay drivers are designed to drive bi-stable polarized latching relays that connect and disconnect electrical power in smart electronic meters. The FEBFAN324x_001NDA evaluation board is designed to evaluate any of the products in the FAN324x series, such as FAN3240 or FAN3241.

The output of the FAN324x is rated for operation with supply rails from 8 V to 60 V. The filter / timer block prevents inadvertent switching from noisy input signals by providing input-pulse qualification (t_{QUAL}) and maximum output pulse-width limit (t_{MAX}). The parameters are factory adjustable and additional configurations are available. XOR input protection is also provided to prevent both outputs from being on at the same time. The Under-Voltage Lockout (UVLO) function disables the outputs until the supply voltage is within the operating range.

The FAN324x has two separate driver channels for the relay-open and relay-close signals needed to operate dual-coil relays. One enable/disable pin allows shutdown of both channels independent of the input signals. An internal thermal shutdown (TSD) function is provided for thermal protection.

This FEBFAN324x_001NDA evaluation board uses a two-layer Printed Circuit Board (PCB). The size of the board is designed to be small enough to be evaluated in confined spaces of the meter. Its form factor is 45.72 x 20.32 mm (1.8 x 0.8 inches).

2. Photographs

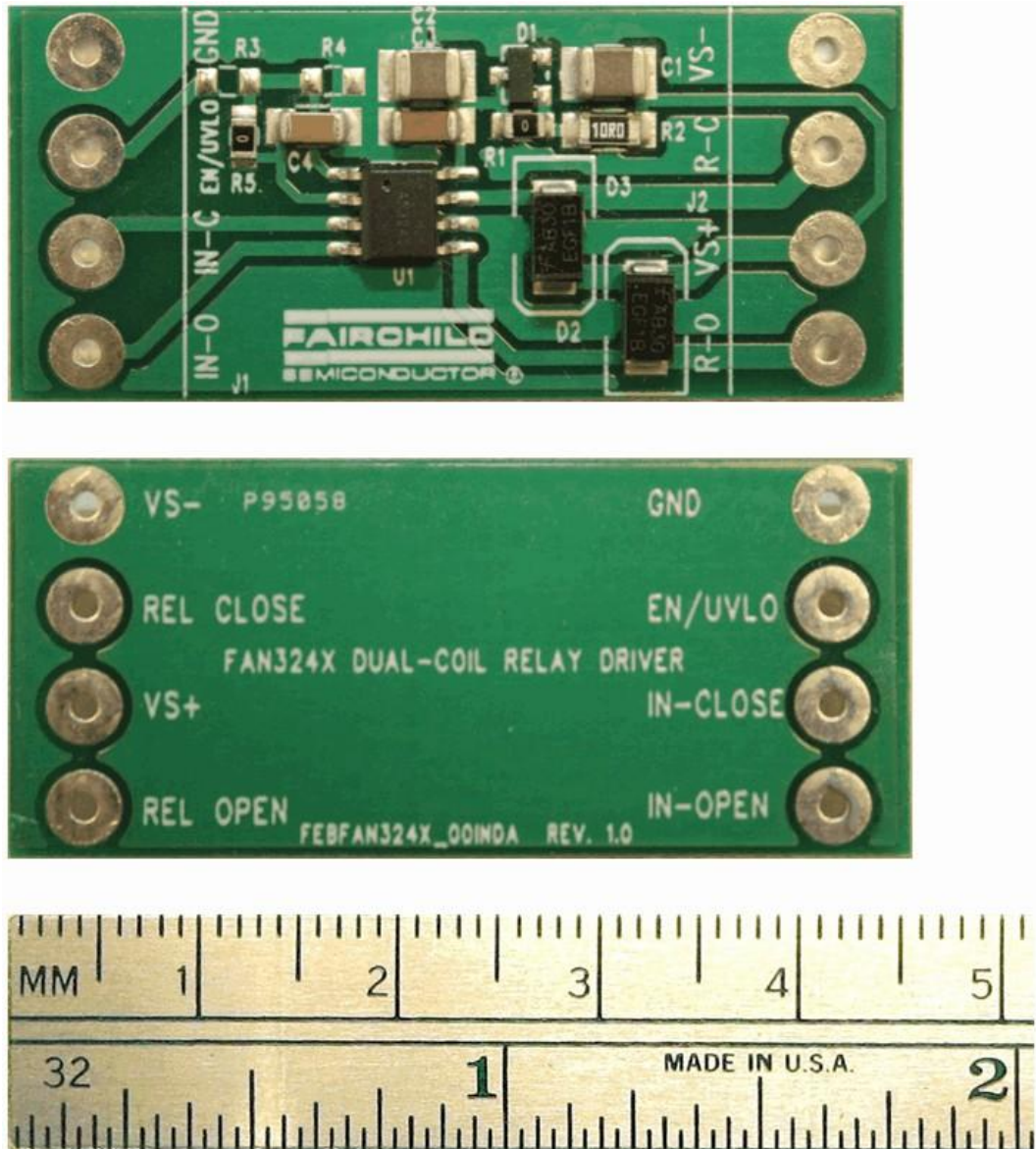

Figure 1. FEBFAN324x_001NDA, Top and Bottom View, 45.7 x 20.3 mm (1.8 x 0.8 inches)

3. Key Features of FAN324x

- 8-V to 60-V Operation Range for use with 12-V, 24-V, or 48-V Relays
- Strong DC Current to Break through Welded Contacts without External Switches
- Integrated Linear Regulator for Isolated or Non-Isolated Meter Power Designs
- Accurate Input Filter Time and XOR Input Protection
- Accurate Maximum Output Pulse Width
- Two Output Operating Modes:
 - Follow Input Width Up to Maximum Value
 - Fixed Maximum Output Pulse Width
- 3.3-V or 5-V Square-Wave Logic Input Signals
- Enable Pin for Operational Flexibility
- Internal Thermal Shutdown Protection (TSD)
- Rated from -40°C to $+105^{\circ}\text{C}$ Ambient

3.1. Applications

- Smart E-Meters
- Energy Generation & Distribution
- Building and Home Control
- Industrial Dual-Coil Relay-Driving Applications

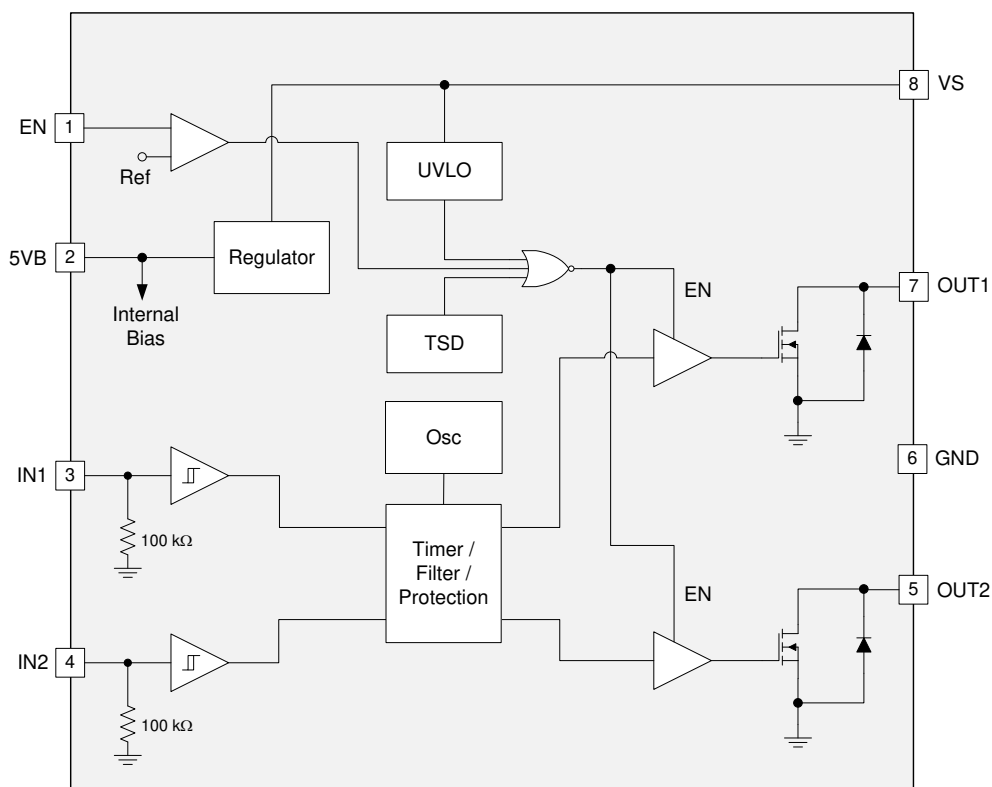

Figure 2. Block Diagram

4. Specifications

This evaluation board has been designed and optimized for the conditions in Table 1.

Table 1. Recommended Operating Conditions

Symbol	Parameter	Min.	Typ.	Max.	Unit
V_S	Output Supply Voltage Range	8		60	V
V_{EN}	Enable Voltage EN	0	3.3 to 5.0	5.5	V
V_{IN}	Input Voltage IN1, IN2	0	3.3 to 5.0	5.5	V
C_{VS}	Bypass Capacitor at VS Pin		1		μ F
C_{5VB}	Bypass Capacitor at 5VB Pin	100	220		nF
T_A	Operating Ambient Temperature	-40		+105	$^{\circ}$ C

5. Test Setup

Before applying power to the FEBFAN324X_001NDA evaluation board, the DC bias supply for V_S and a dual-coil relay load for outputs should be connected to the board as shown in Figure 3.

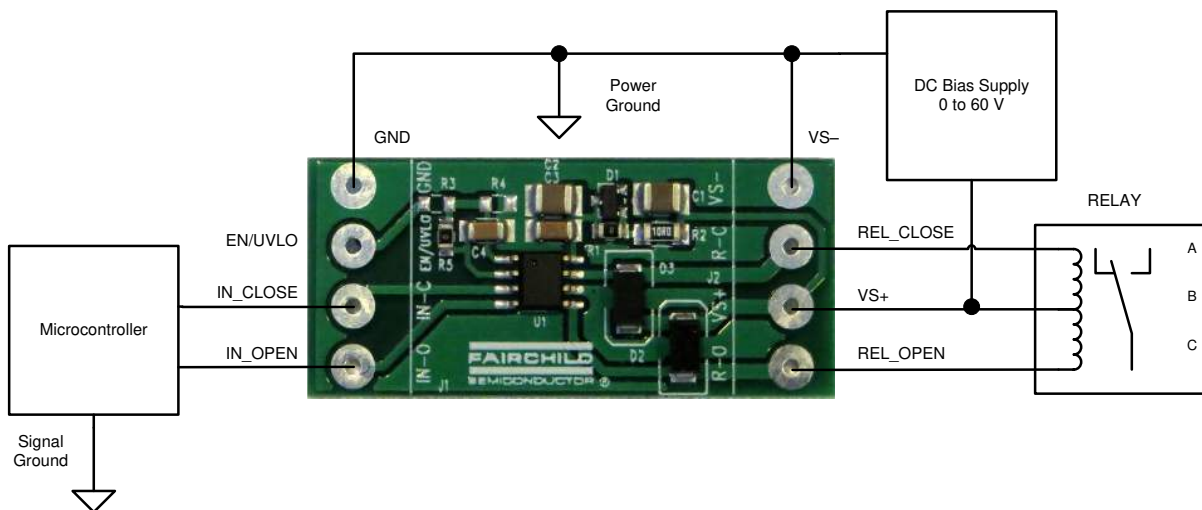

Figure 3. Recommended Test Set-Up

6. Schematic

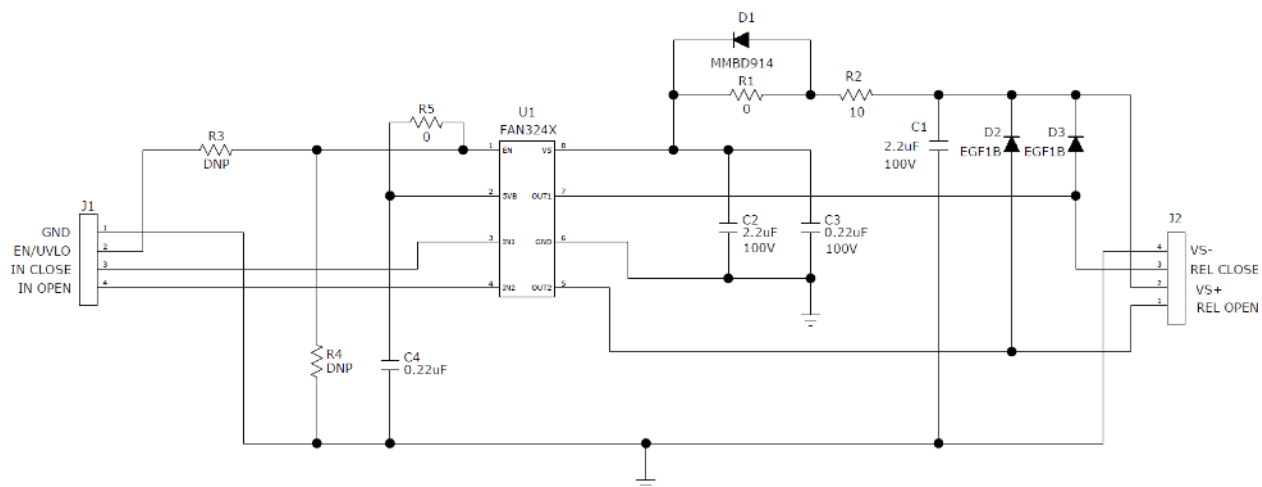

Figure 4. Evaluation Board Schematic

Note 1:

The IC is hardwired to be enabled by default and no connection is needed for the EN / UVLO pin. There are two ways to use the EN / UVLO pin.

- To control the IC and the board using the enable / disable operation. R5 must be removed first and the R3 (0 Ω) installed.
- To monitor and disable based on other vital voltages in the system, such as the supply voltage for the logic generating the control signals or the power rail of the relay. In this case, R5 must be removed and R3/R4 divider be added.

Note 2:

The board is built with D1 and R1 both populated. In this configuration, D1 is shorted out and the IC is running on of a filtered version of the relay bias voltage, VS. The filtering is provided by R2 and C2.

If the relay bias voltage is not stiff enough and it is anticipated that the VS voltage might collapse or drop below the UVLO turn-off threshold during switching, R1 should be removed. If R1 is removed, D1 is reverse biased and de-couples the IC bias power across C2 from the temporary low-voltage across the relay bias voltage bypass capacitor, C1.

Due to the very low operating current (I_{SUPPLY}) of the FAN324x drivers, the IC bias voltage can be kept above the UVLO turn-off threshold for an extended period of time (t_{HOLDUP}) given by the following relationship:

$$t_{HOLDUP} = C2 \cdot \frac{VS_{NOM} - V_{UVLO_OFF}}{I_{SUPPLY}} \quad (1)$$

7. Bill of Materials (BOM)

Item	Qty	Reference	Value	Part Number	Description	Manufacturer	Package
1	2	C1, C2	2.2 μ F	HMK325B7225KN-T	CAP, SMD, CERAMIC, 100 V, X7R	Taiyo Yuden	1210
2	1	C3	0.22 μ F	C3216X7R2A224K	CAP, SMD, CERAMIC, 100 V, X7R	TDK	1206
3	1	C4	0.22 μ F		CAP, SMD, CERAMIC, 6.3 V, X7R	STD	1206
4	1	D1		MMBD914	Diode, Standard, 100 V, 200 mA,	Fairchild Semiconductor	SOT-23
5	2	D2, D3		EGF1B	DIODE FAST REC 1 A 100 V	Fairchild Semiconductor	SMA
6	2	J1, J2	DNP	ED120/4DS	Terminal Block, 4 Pos,	On Shore Technology, Inc.	Thru-Hole
7	2	R1, R5	0 Ω		RES, SMD, 1/8 W	STD	805
8	1	R2	10 Ω		RES, SMD, 1/4 W	STD	1206
9	2	R3, R4	DNP		RES, SMD, 1/8 W	STD	805
10	1	U1		FAN3240TMX, FAN3241TMX, (or any product in the FAN324xTMX family)	Smart Dual-Coil Relay Driver	Fairchild Semiconductor	SOIC-8

Notes:

1. DNP = Do Not Populate
2. STD = Standard Component

8. Test Results: FAN3240

The following tests are for FAN3240 with these operational parameters:

- $t_{QUAL} = 15$ ms nominal
- $t_{MAX} = 150$ ms nominal
- Edge-triggered operation
- Output follows input up to t_{MAX} if input pulse width is greater than t_{QUAL}

The relay used for testing is K100A-10-024B024-R, a 100-A, 277-V_{AC}-rated, dual-coil, power-latching relay from KG Technologies with the coil voltage of 24 V (see [specification sheet](#)).



Figure 5. Power-Latching Relay

8.1. Input Qualification

All input pulses shorter than the set qualification time, t_{QUAL} , are ignored.

Both IN_1 and IN_2 pulse widths are shorter than the t_{QUAL} value of 15 ms; both are ignored and OUT_1 and OUT_2 remain off.

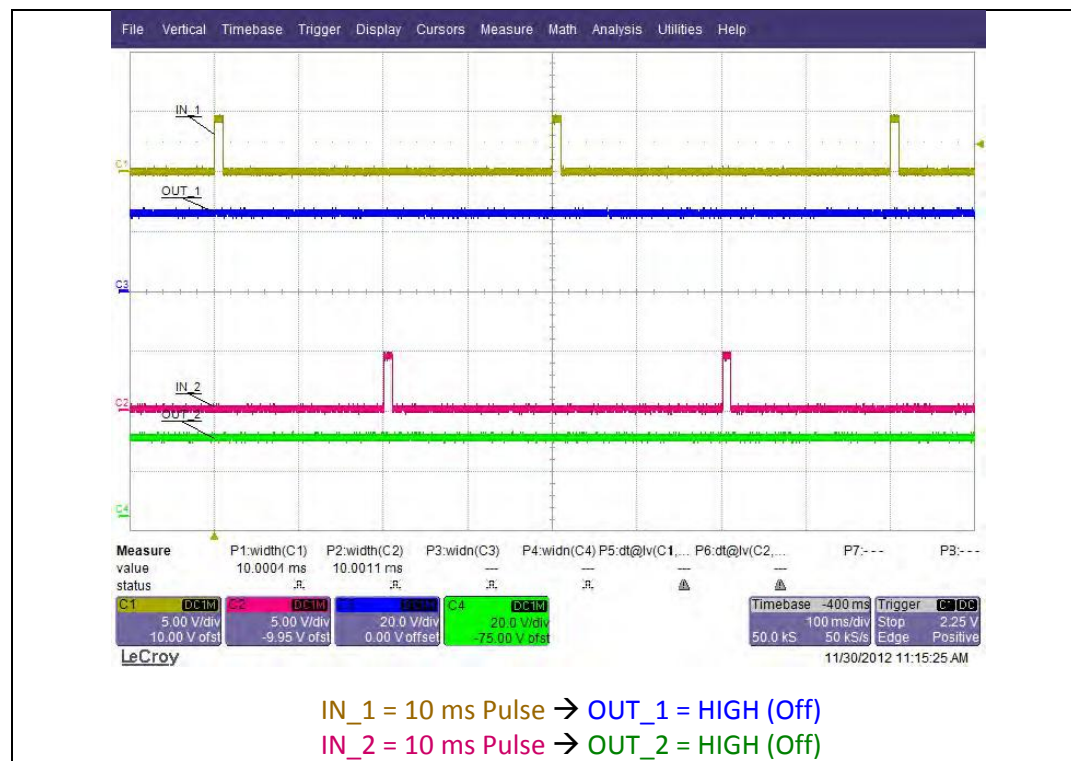

Figure 6. Input Qualification

8.2. Operation with Qualified Inputs

Input signals with a pulse width greater than t_{QUAL} are considered valid / qualified inputs.

Both IN_1 and IN_2 are qualified inputs as they are longer than t_{QUAL} . The outputs follow the input pulse width up to t_{MAX} . OUT_1 follows the input pulse width of 50 ms because it is shorter than t_{MAX} . However, OUT_2 pulse-width is terminated at t_{MAX} because the IN_2 pulse is longer than t_{MAX} .

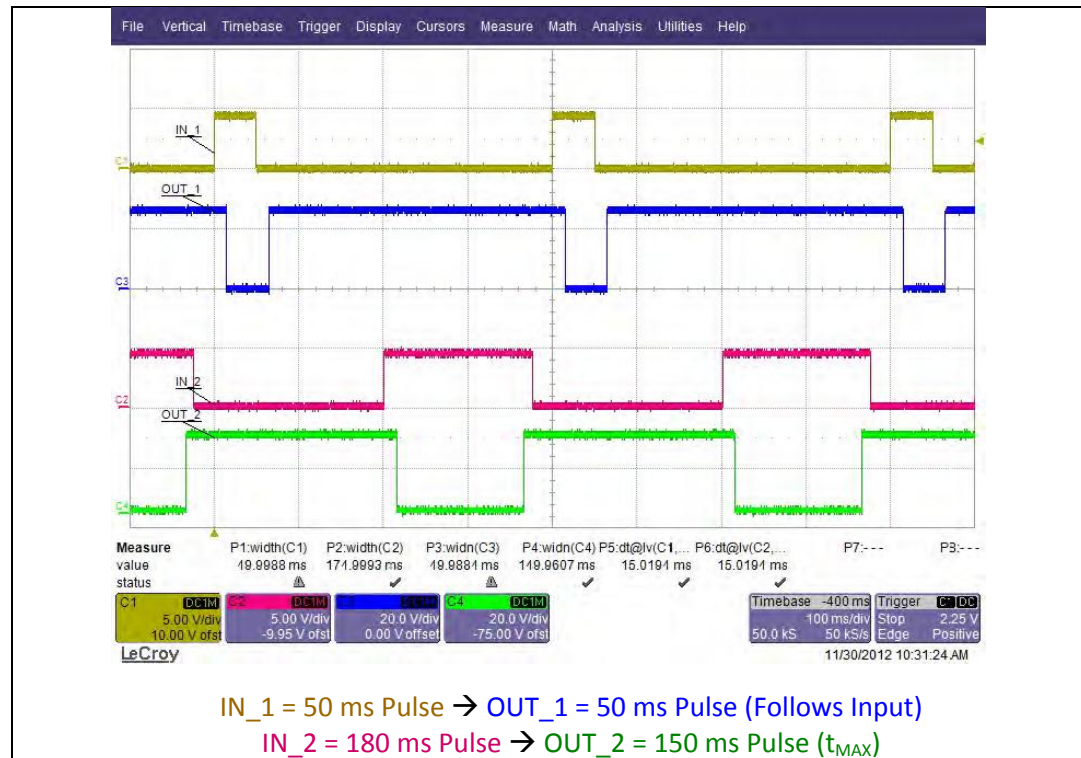

Figure 7. Operation with Qualified Inputs

8.3. Operation with Input Permanently HIGH

These tests are for a condition where the input pin gets stuck HIGH or is permanently HIGH from start, emulating a signal source failure or an assembly problem, such as a solder joint shorting the input pin to a voltage interpreted at the input as a logic HIGH signal.

As the IN_1 pulse width is longer than the maximum allowable pulse width (t_{MAX}), the OUT_1 pulse is terminated at t_{MAX} .

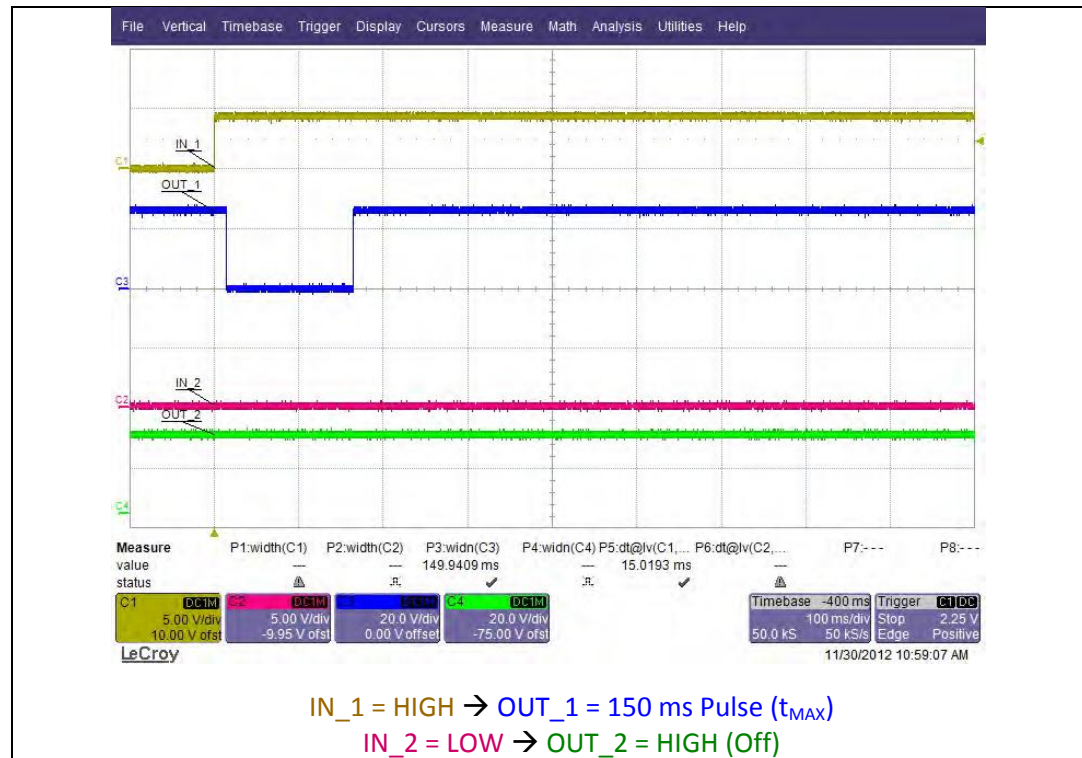

Figure 8. Input Longer than t_{MAX}

8.4. Enable / Disable Functionality

When the EN pin is pulled LOW, the IC must terminate any existing output pulse and prevent any further pulses to the relay drive outputs.

In the first input signal shown in Figure 9, note the IN_1 pulse width is longer than the maximum allowable pulse width (t_{MAX}) and the OUT_1 pulse has the maximum width of t_{MAX} . When the EN signal is pulled LOW during the second OUT_1 signal, the output pulse terminates immediately.

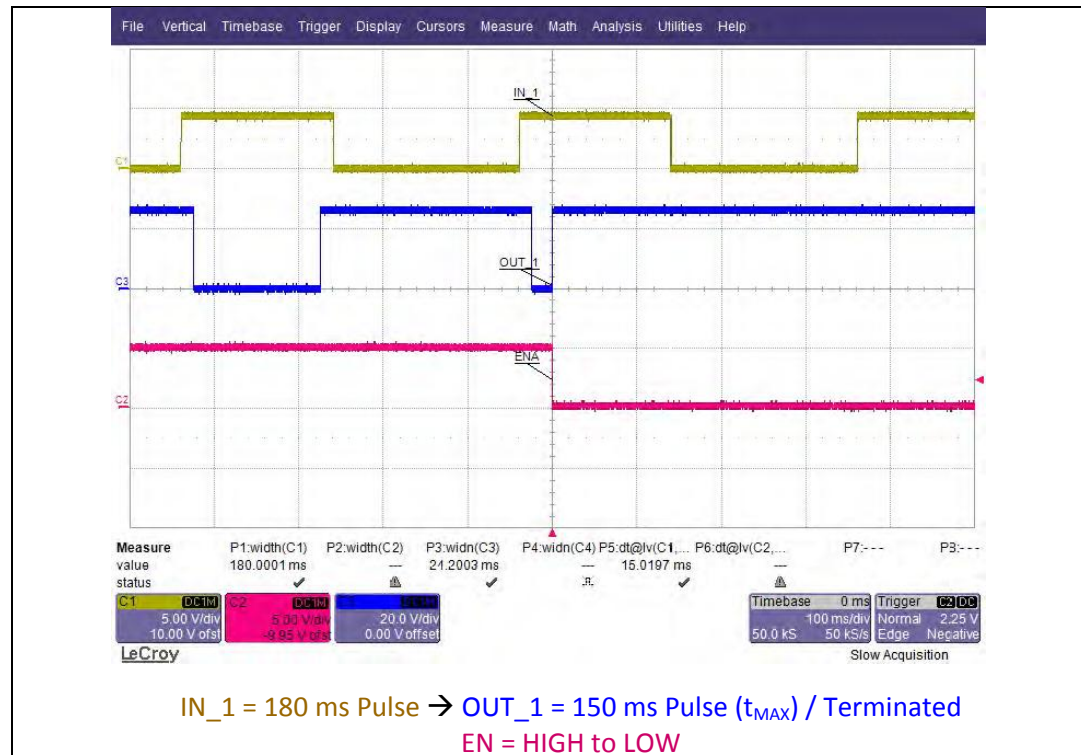

Figure 9. Enable / Disable Functionality

8.5. Noise on the Inactive Input

While one of the inputs receives a valid, qualified input; the other input might see significant noise level above the input threshold level. The noise can be especially strong right after the output of the IC turns on and drives the contactor switch.

The noise signature on IN_1 is ignored because its pulse width is shorter than t_{QUAL} .

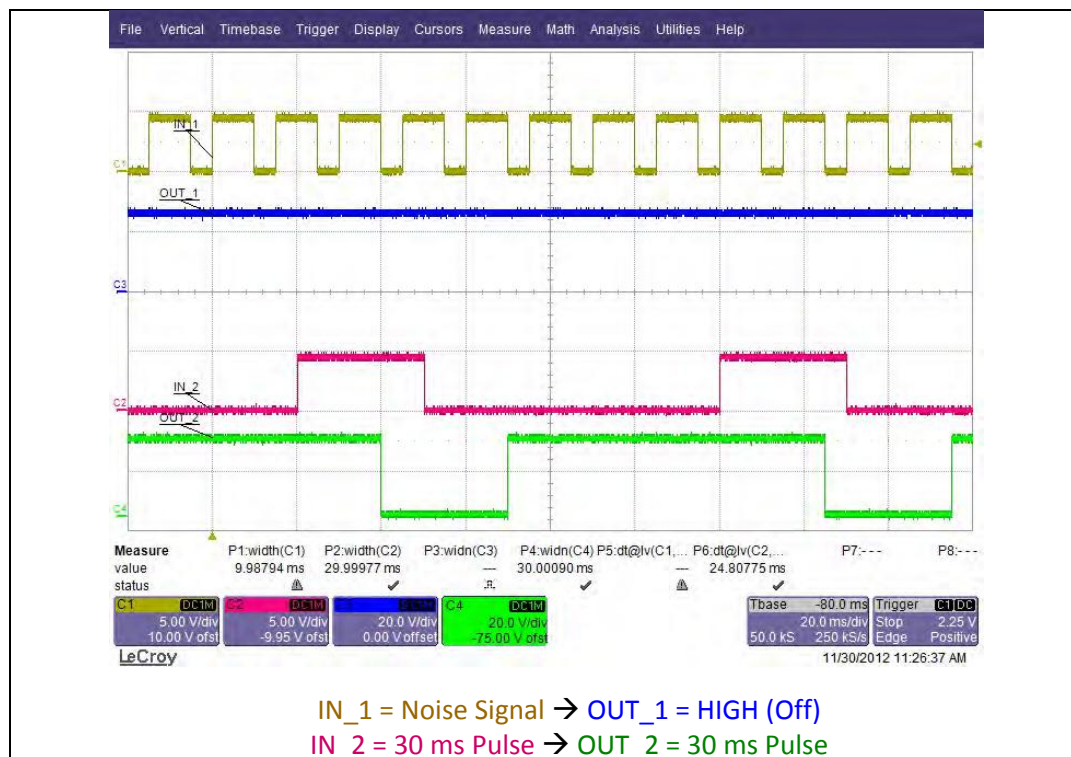

Figure 10. Noise on Inactive Input

8.6. XOR Protection

The XOR protection implemented in the FAN324x devices prohibits output pulses when two qualified input signals are received at the same time. The XOR protection works when both inputs are asserted together or a second qualified input is received while the first one is being qualified.

Both cases below show that the XOR protection prevents simultaneous drive signals being delivered to the two coils of the relay.

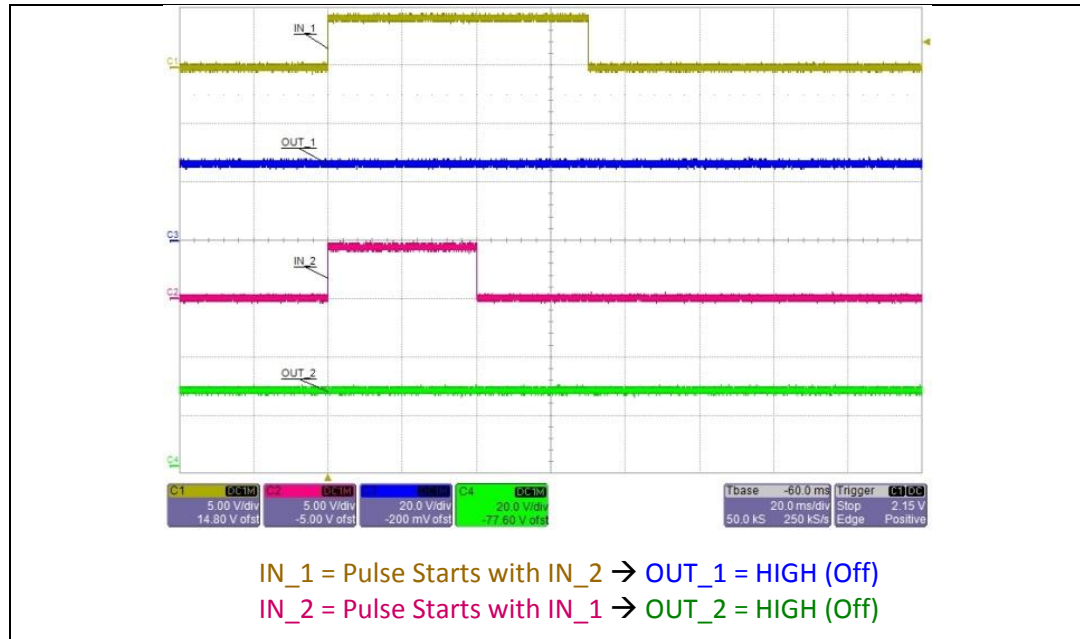

Figure 11. Simultaneous Insertion of Two Qualified Inputs

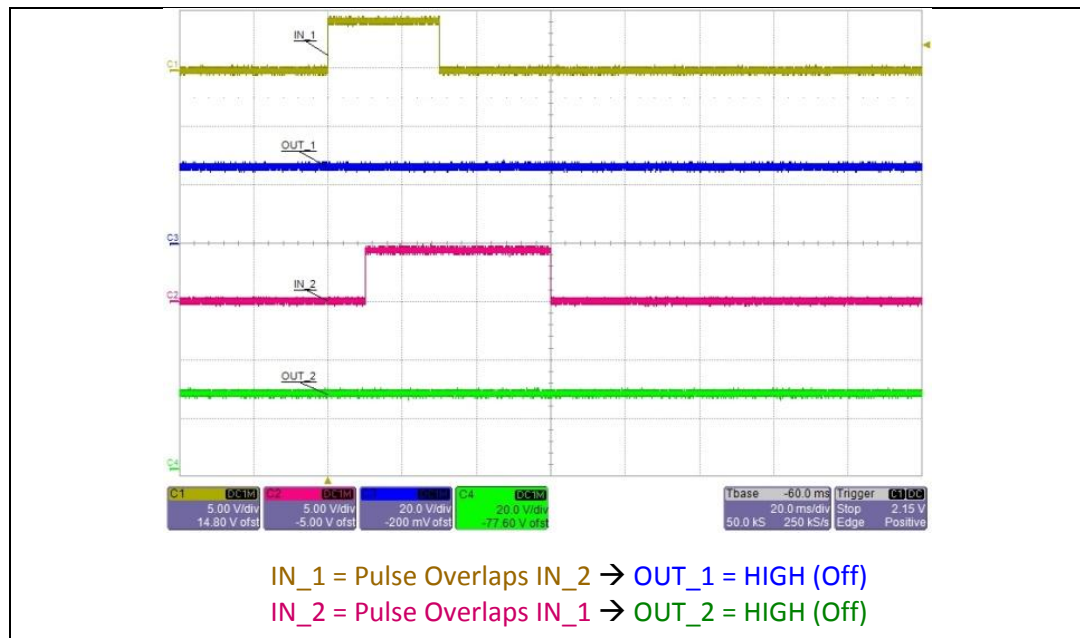

Figure 12. Overlapping Qualified Inputs

9. Test Results: FAN3241

The following tests are for FAN3241 with these operational parameters:

- $t_{QUAL} = 1 \text{ ms}$ nominal
- $t_{MAX} = 30 \text{ ms}$ nominal
- Edge-triggered operation
- Output pulse always equal to t_{MAX} , regardless of qualified input pulse width

The relay used for testing is K100A-10-024B024-R, a 100-A, 277-V_{AC}-rated, dual-coil, power-latching relay from KG Technologies with the coil voltage of 24 V (see [specification sheet](#)).



Figure 13. Power-Latching Relay

9.1. Input Qualification

All input pulses shorter than the set qualification time, t_{QUAL} , are ignored.

Both IN_1 and IN_2 pulse widths are shorter than the t_{QUAL} value of 1 ms and both are ignored as OUT_1 and OUT_2 remain off.

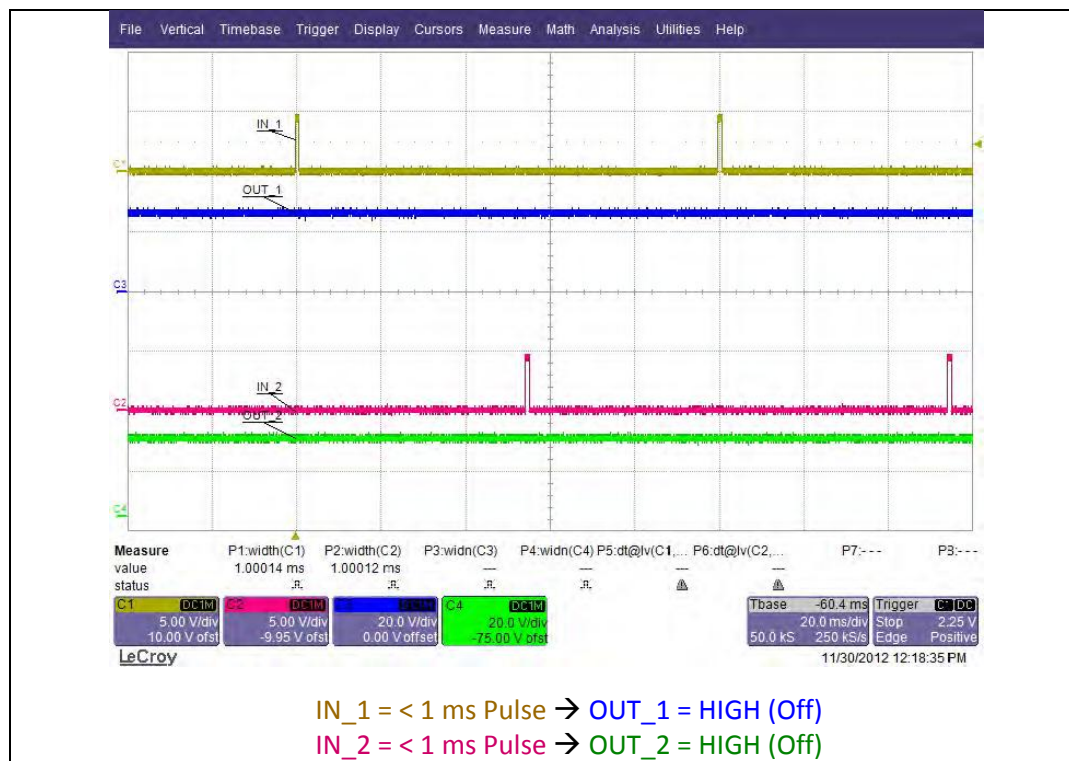

Figure 14. Input Qualification

9.2. Operation with Qualified Inputs

Input signals with a pulse width greater than t_{QUAL} are considered valid / qualified inputs.

The output pulse width is always equal to t_{MAX} , regardless of qualified input pulse widths.

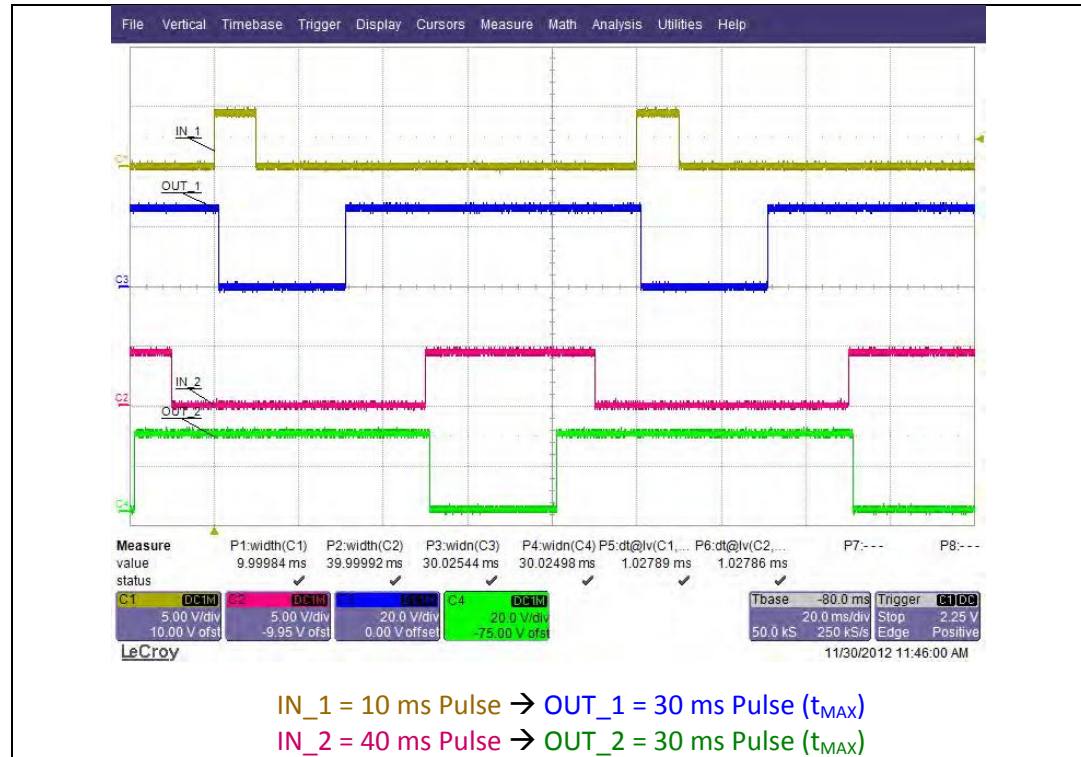

Figure 15. Operation with Qualified Inputs

9.3. Operation with Input Permanently HIGH

These tests are for a condition where the input pin gets stuck HIGH or is permanently HIGH from startup emulating a signal source failure or an assembly problem, such as a solder joint shorting the input pin to a voltage interpreted at the input as a logic HIGH signal.

As the IN_1 pulse width is longer than the maximum allowable pulse width (t_{MAX}), the OUT_1 pulse is terminated at t_{MAX} . Note that OUT_2 does not switch even with valid IN_2 signals due to XOR protection.

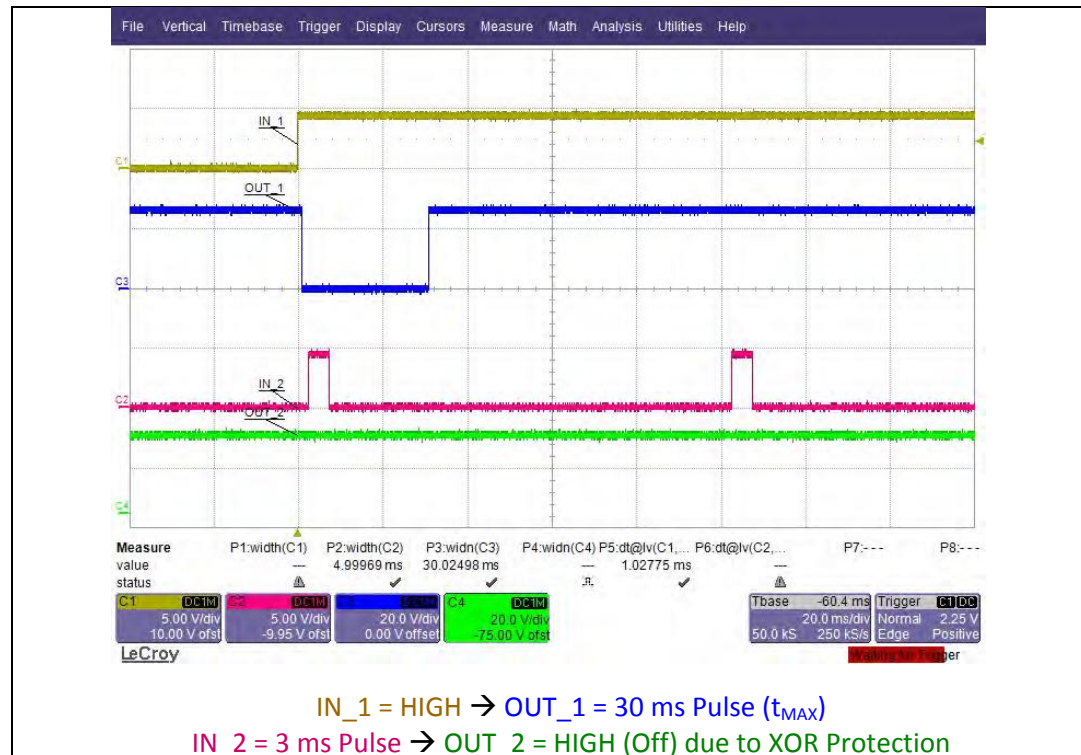

Figure 16. Input Longer than t_{MAX}

9.4. Enable / Disable Functionality

When the EN pin is pulled LOW, the IC must terminate any existing output pulse and prevent any further pulses to the relay drive outputs.

When the EN signal is pulled LOW during the switching of OUT_1, the output is terminated immediately.

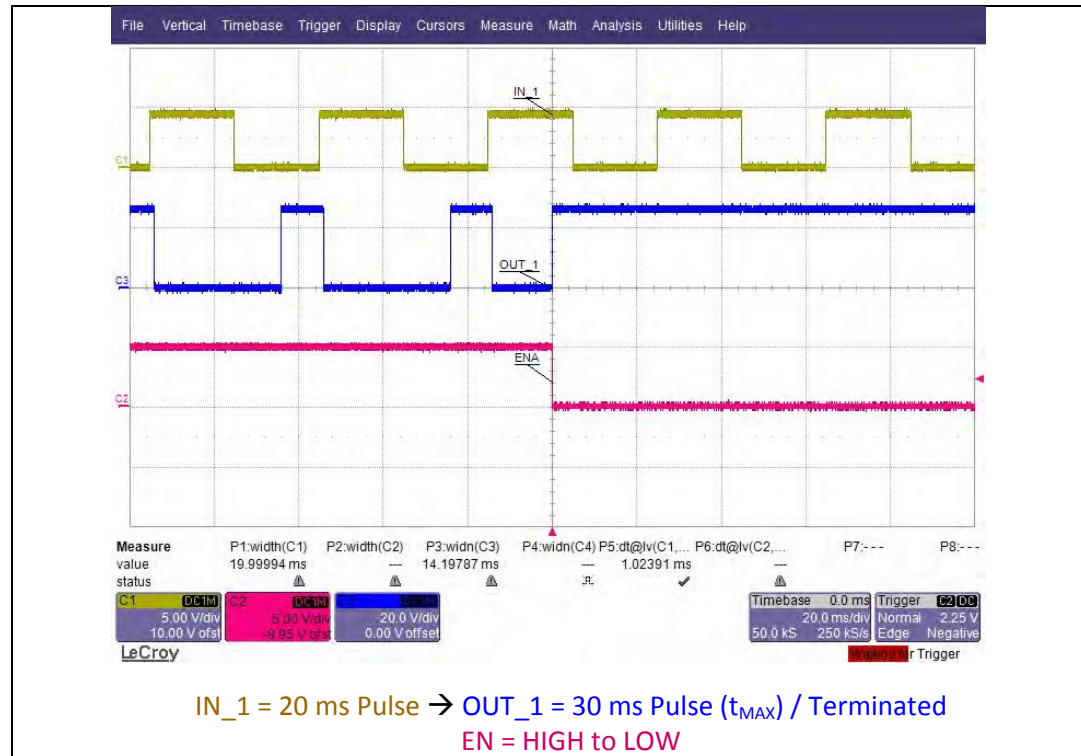

Figure 17. Enable / Disable Functionality

9.5. Noise on the Inactive Input

While one of the inputs receives a valid, qualified input; the other input might see significant noise level above the input threshold level. The noise can be especially strong right after the output of the IC turns on and drives the contactor switch.

The noise signature on IN_2 is ignored because its pulse width is shorter than t_{QUAL} .

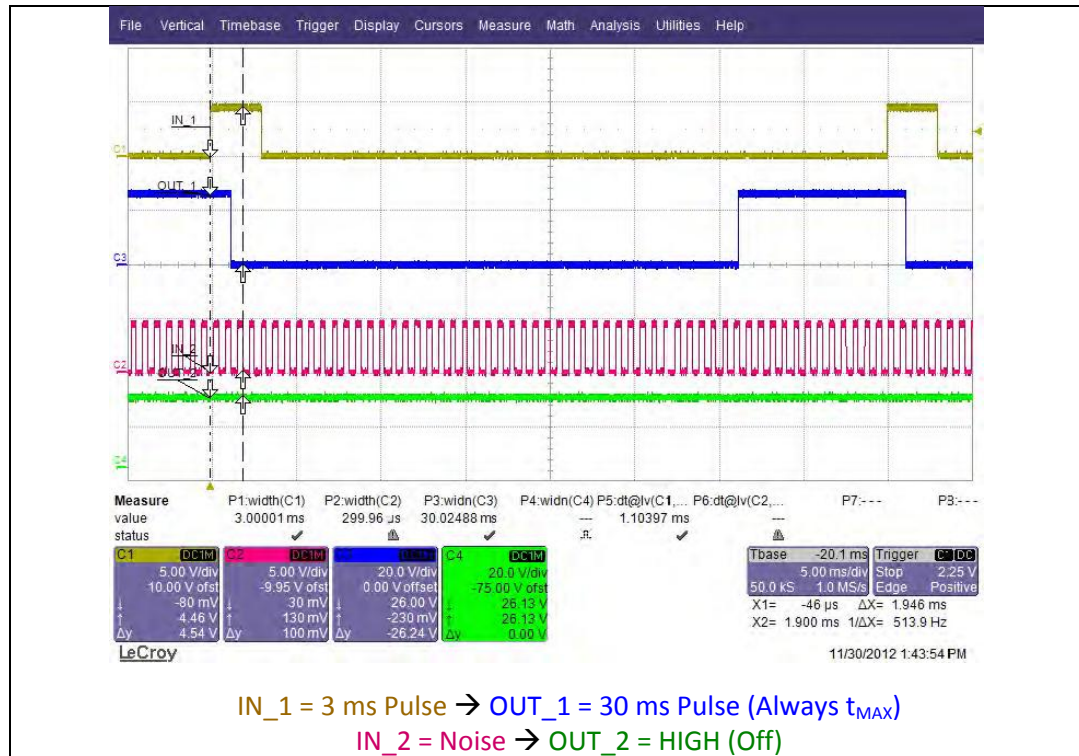

Figure 18. Noise on the Inactive INPUT

9.6. XOR Protection

The XOR protection implemented in the FAN324x prohibits output pulses when two qualified input signals are received at the same time. The XOR protection works when both inputs are asserted together or a second qualified input is received while the response to the first qualified input is being executed.

Both cases below show that the XOR protection prevents simultaneous drive signals being delivered to the two coils of the relay.

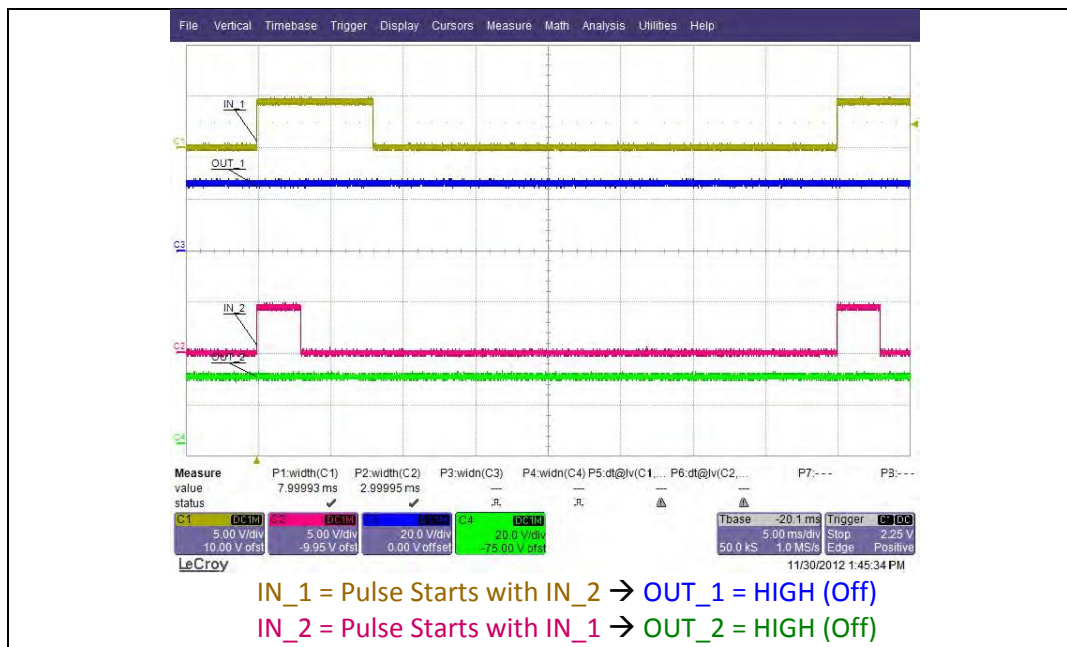

Figure 19. Simultaneous Insertion of Two Qualified Inputs

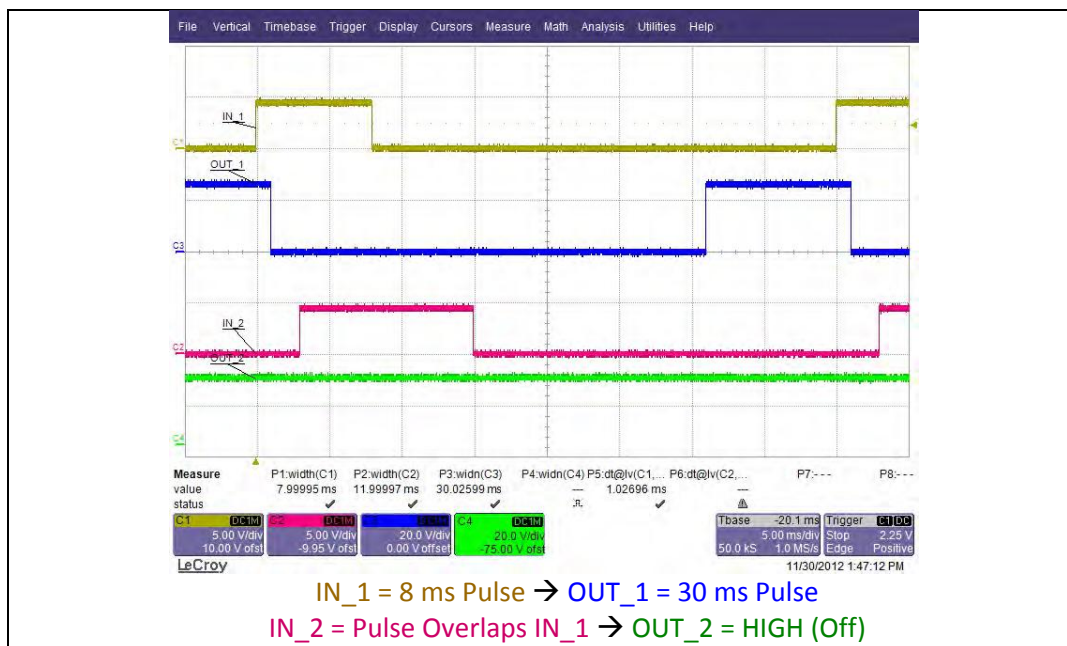

Figure 20. Overlapping Qualified Inputs

10. References

- [1] [FAN3240 / FAN3241 — Smart Dual-Coil Relay Drivers](#)

11. Ordering Information

Orderable Part Number	Description
FEBFAN3240_001NDA	FAN3240 Evaluation Board
FEBFAN3241_001NDA	FAN3241 Evaluation Board

12. Revision History

Date	Revision	Description
May 2013	0.0.1	Initial release

WARNING AND DISCLAIMER

Replace components on the Evaluation Board only with those parts shown on the parts list (or Bill of Materials) in the Users' Guide. Contact an authorized Fairchild representative with any questions.

This board is intended to be used by certified professionals, in a lab environment, following proper safety procedures. Use at your own risk. The Evaluation board (or kit) is for demonstration purposes only and neither the Board nor this User's Guide constitute a sales contract or create any kind of warranty, whether express or implied, as to the applications or products involved. Fairchild warrants that its products meet Fairchild's published specifications, but does not guarantee that its products work in any specific application. Fairchild reserves the right to make changes without notice to any products described herein to improve reliability, function, or design. Either the applicable sales contract signed by Fairchild and Buyer or, if no contract exists, Fairchild's standard Terms and Conditions on the back of Fairchild invoices, govern the terms of sale of the products described herein.

DISCLAIMER

FAIRCHILD SEMICONDUCTOR RESERVES THE RIGHT TO MAKE CHANGES WITHOUT FURTHER NOTICE TO ANY PRODUCTS HEREIN TO IMPROVE RELIABILITY, FUNCTION, OR DESIGN. FAIRCHILD DOES NOT ASSUME ANY LIABILITY ARISING OUT OF THE APPLICATION OR USE OF ANY PRODUCT OR CIRCUIT DESCRIBED HEREIN; NEITHER DOES IT CONVEY ANY LICENSE UNDER ITS PATENT RIGHTS, NOR THE RIGHTS OF OTHERS.

LIFE SUPPORT POLICY

FAIRCHILD'S PRODUCTS ARE NOT AUTHORIZED FOR USE AS CRITICAL COMPONENTS IN LIFE SUPPORT DEVICES OR SYSTEMS WITHOUT THE EXPRESS WRITTEN APPROVAL OF THE PRESIDENT OF FAIRCHILD SEMICONDUCTOR CORPORATION.

As used herein:

- Life support devices or systems are devices or systems which, (a) are intended for surgical implant into the body, or (b) support or sustain life, or (c) whose failure to perform when properly used in accordance with instructions for use provided in the labeling, can be reasonably expected to result in significant injury to the user.
- A critical component is any component of a life support device or system whose failure to perform can be reasonably expected to cause the failure of the life support device or system, or to affect its safety or effectiveness.

ANTI-COUNTERFEITING POLICY

Fairchild Semiconductor Corporation's Anti-Counterfeiting Policy. Fairchild's Anti-Counterfeiting Policy is also stated on our external website, www.fairchildsemi.com, under Sales Support.

Counterfeiting of semiconductor parts is a growing problem in the industry. All manufacturers of semiconductor products are experiencing counterfeiting of their parts. Customers who inadvertently purchase counterfeit parts experience many problems such as loss of brand reputation, substandard performance, failed applications, and increased cost of production and manufacturing delays. Fairchild is taking strong measures to protect ourselves and our customers from the proliferation of counterfeit parts. Fairchild strongly encourages customers to purchase Fairchild parts either directly from Fairchild or from Authorized Fairchild Distributors who are listed by country on our web page cited above. Products customers buy either from Fairchild directly or from Authorized Fairchild Distributors are genuine parts, have full traceability, meet Fairchild's quality standards for handling and storage and provide access to Fairchild's full range of up-to-date technical and product information. Fairchild and our Authorized Distributors will stand behind all warranties and will appropriately address any warranty issues that may arise. Fairchild will not provide any warranty coverage or other assistance for parts bought from Unauthorized Sources. Fairchild is committed to combat this global problem and encourage our customers to do their part in stopping this practice by buying direct or from authorized distributors.

EXPORT COMPLIANCE STATEMENT

These commodities, technology, or software were exported from the United States in accordance with the Export Administration Regulations for the ultimate destination listed on the commercial invoice. Diversion contrary to U.S. law is prohibited.

U.S. origin products and products made with U.S. origin technology are subject to U.S. Re-export laws. In the event of re-export, the user will be responsible to ensure the appropriate U.S. export regulations are followed.