

Spezifikation für Freigabe / specification for release

Kunde / customer :
 Artikelnummer / part number : **7498111001**
 Bezeichnung : **LAN-Übertrager WE-RJ45LAN 1000Base-T**
 description : **LAN-Transformer WE-RJ45LAN 1000Base-T**



DATUM / DATE : 2016-06-10

A Mechanische Abmessungen / dimensions :

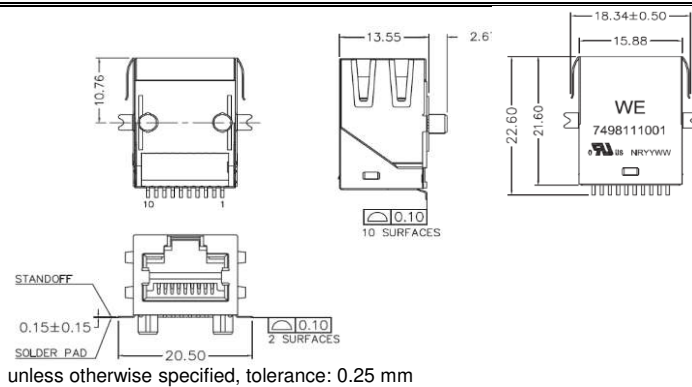

B Lötpad / soldering spec. :

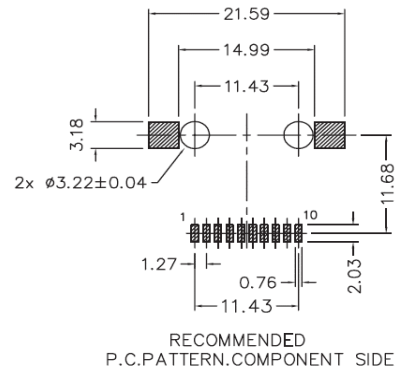

C Elektrische Eigenschaften / electrical properties :

Eigenschaften / properties	Testbedingungen /		Wert / value	Einheit / unit	tol.
Induktivität / Inductance	100kHz / 100mV @ 8mA DC-Bias	OCL	350	μH	min.
Übersetzungsverhältnis / Turns ratio	100kHz / 100mV	TR	1 : 1	Tx	2%
			1 : 1	Rx	
Insertion Loss	1-100MHz	IL	-1.0	dB	max.
Return Loss	1-30MHz	RL	-18	dB	min.
	30-60MHz		-15		
	60-80MHz		-12		
	80-100MHz		-10		
Common Mode Rejection	1-30MHz	CMR	-35	dB	min.
	30-100MHz		-30		
Crosstalk	1-30MHz	CT	-37	dB	min.
	30-60MHz		-32		
	60-100MHz		-27		

D Prüfgeräte / test equipment :

Agilent 4395A Network Analyzer

E Testbedingungen / test conditions :

Luftfeuchtigkeit / humidity: 33%
 Umgebungstemperatur / temperature: +25°C

F Werkstoffe & Zulassungen / material & approvals :

Basismaterial / base material: Ferrit/ ferrite
 Draht / wire: QPN 180
 Kontaktmaterial/ contact plating: 100% tin w. nickel underplating
 30μ"gold plating on contact area
 Gehäuse / housing: Thermoplastic UL-94V0
 LED
 Shield: 50μ" nickel over 0.01" cooper alloy

G Eigenschaften / general specifications :

Betriebstemp. / operating temperature: -40°C - + 85°C
 Hochspannungsprüfung / Hipot test: 1500Vrms 1min.
 Geeignet für 10/100Base-TX gemäß IEEE 802.3u /
 Compliant with IEEE 802.3u for 10/100Base-TX-Applications
 Auto MDIX fähig / Auto MDIX capable
 UL File: E331896

Freigabe erteilt / general release:	Kunde / customer		
.....		
Datum / date	Unterschrift / signature		
	Würth Elektronik		
.....	Mle	Revision 01 2016-06-10
Geprüft / checked	Kontrolliert / approved	MMai	Revision 00 2016-02-24
		Name	Änderung / modification Datum / date

Würth Elektronik eiSos GmbH & Co.KG

D-74638 Waldenburg · Max-Eyth-Straße 1 - 3 · Germany · Telefon (+49) (0) 7942 - 945 - 0 · Telefax (+49) (0) 7942 - 945 - 400
<http://www.we-online.com>

Spezifikation für Freigabe / specification for release

Kunde / customer :
 Artikelnummer / part number : **7498111001**
 Bezeichnung : **LAN-Übertrager WE-RJ45LAN 1000Base-T**
 description : **LAN-Transformer WE-RJ45LAN 1000Base-T**



DATUM / DATE : 2016-06-10

H Schaltbild / Schematics :

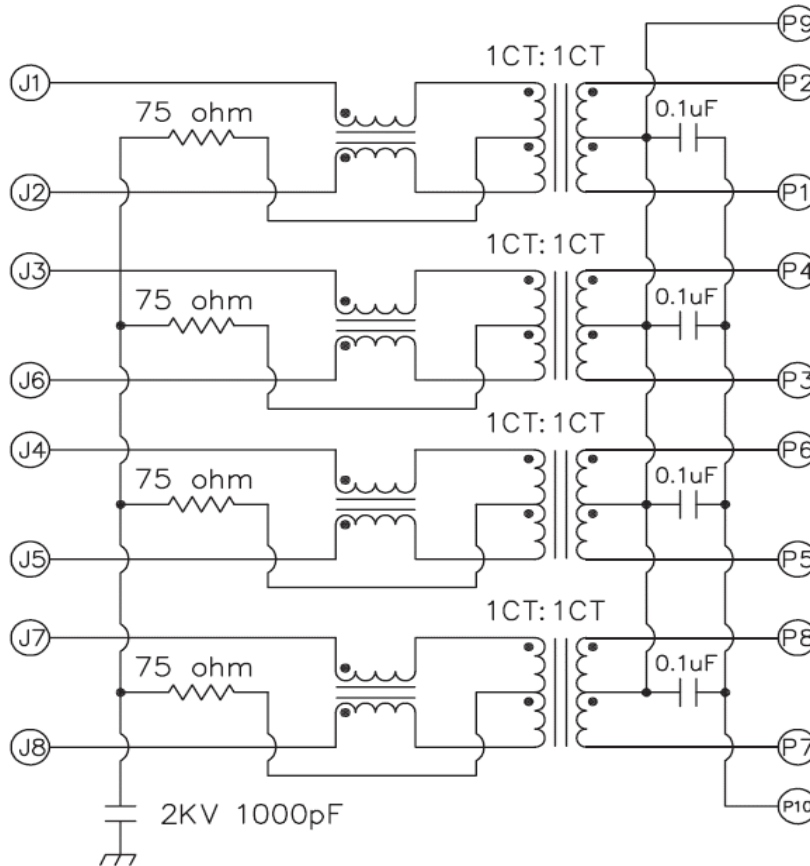

Freigabe erteilt / general release:	Kunde / customer			
.....			
Datum / date	Unterschrift / signature			
	Würth Elektronik			
.....	Mle	Revision 01	2016-06-10
Geprüft / checked	Kontrolliert / approved	MMai	Revision 00	2016-02-24
		Name	Änderung / modification	Datum / date

Würth Elektronik eiSos GmbH & Co.KG

D-74638 Waldenburg · Max-Eyth-Straße 1 - 3 · Germany · Telefon (+49) (0) 7942 - 945 - 0 · Telefax (+49) (0) 7942 - 945 - 400
<http://www.we-online.com>

Spezifikation für Freigabe / specification for release

Kunde / customer :
 Artikelnummer / part number : **7498111001**
 Bezeichnung : **LAN-Übertrager WE-RJ45LAN 1000Base-T**
 description : **LAN-Transformer WE-RJ45LAN 1000Base-T**



DATUM / DATE : 2016-06-10

I Verpackungsspezifikation / package specification :

Tray:

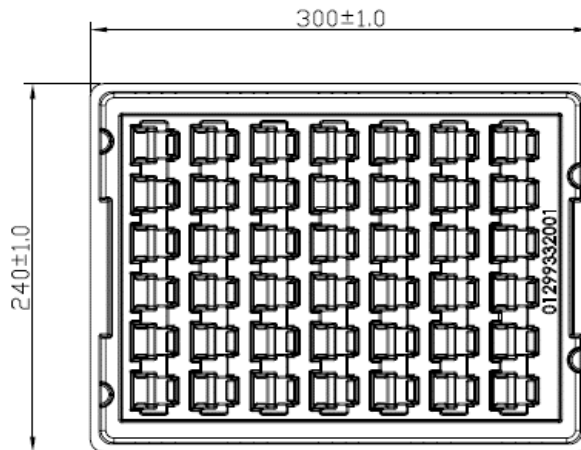

Carton:

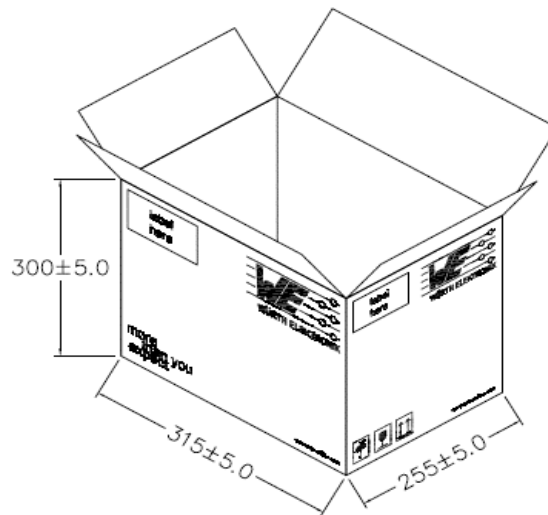

Packing Quantity:

tray= 42pcs
 carton= 588pcs

dimensions in mm

Freigabe erteilt / general release:	Kunde / customer		
.....		
Datum / date	Unterschrift / signature		
	Würth Elektronik		
.....	Mle	Revision 01
Geprüft / checked	Kontrolliert / approved	MMai	Revision 00
		Name	Änderung / modification
			Datum / date

This electronic component has been designed and developed for usage in general electronic equipment. Before incorporating this component into any equipment where higher safety and reliability is especially required or if there is the possibility of direct damage or injury to human body, for example in the range of aero space, aviation, nuclear control, submarine, transportation, (automotive control, train control, ship control), transportation signal, disaster prevention, medical, public information network etc, Würth Elektronik eiSos GmbH must be informed before the design-in stage. In addition, sufficient reliability evaluation checks for safety must be performed on every electronic component which is used in electrical circuits that require high safety and reliability functions or performance.

Würth Elektronik eiSos GmbH & Co.KG

D-74638 Waldenburg · Max-Eyth-Straße 1 · 3 · Germany · Telefon (+49) (0) 7942 - 945 - 0 · Telefax (+49) (0) 7942 - 945 - 400
<http://www.we-online.com>