

## Features

- Internal Frequency-to-voltage Converter
- Externally Controlled Integrated Amplifier
- Automatic Soft Start with Minimized “Dead Time”
- Voltage and Current Synchronization
- Retriggering
- Triggering Pulse Typically 155 mA
- Internal Supply-voltage Monitoring
- Temperature-compensated Reference Source
- Current Requirement  $\leq 3$  mA

Electrostatic sensitive device.

Observe precautions for handling.



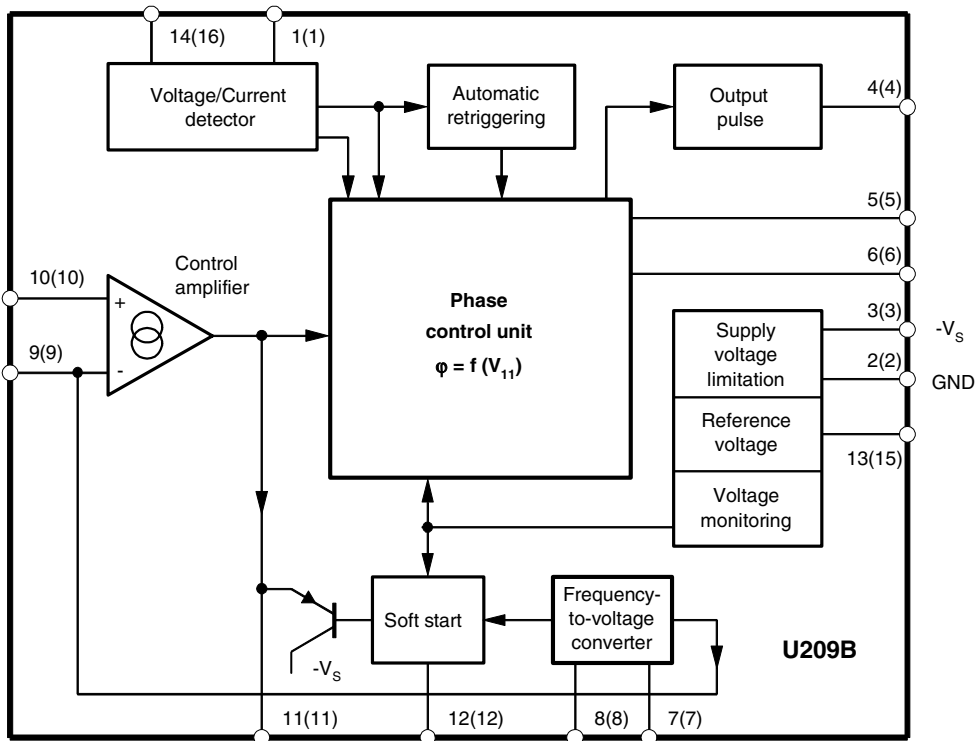
## Phase Control IC for Tacho Applications

## Description

The integrated circuit U209B is designed as a phase-control circuit in bipolar technology with an internal frequency-to-voltage converter. The device includes an internal open-loop amplifier, which means it can be used for motor speed control with tacho feedback.

The U209B is a 14-pin shrink version of the U211B with reduced features. Using the U209B, the designer is able to realize sophisticated as well as economic motor control systems.

Figure 1. Block Diagram



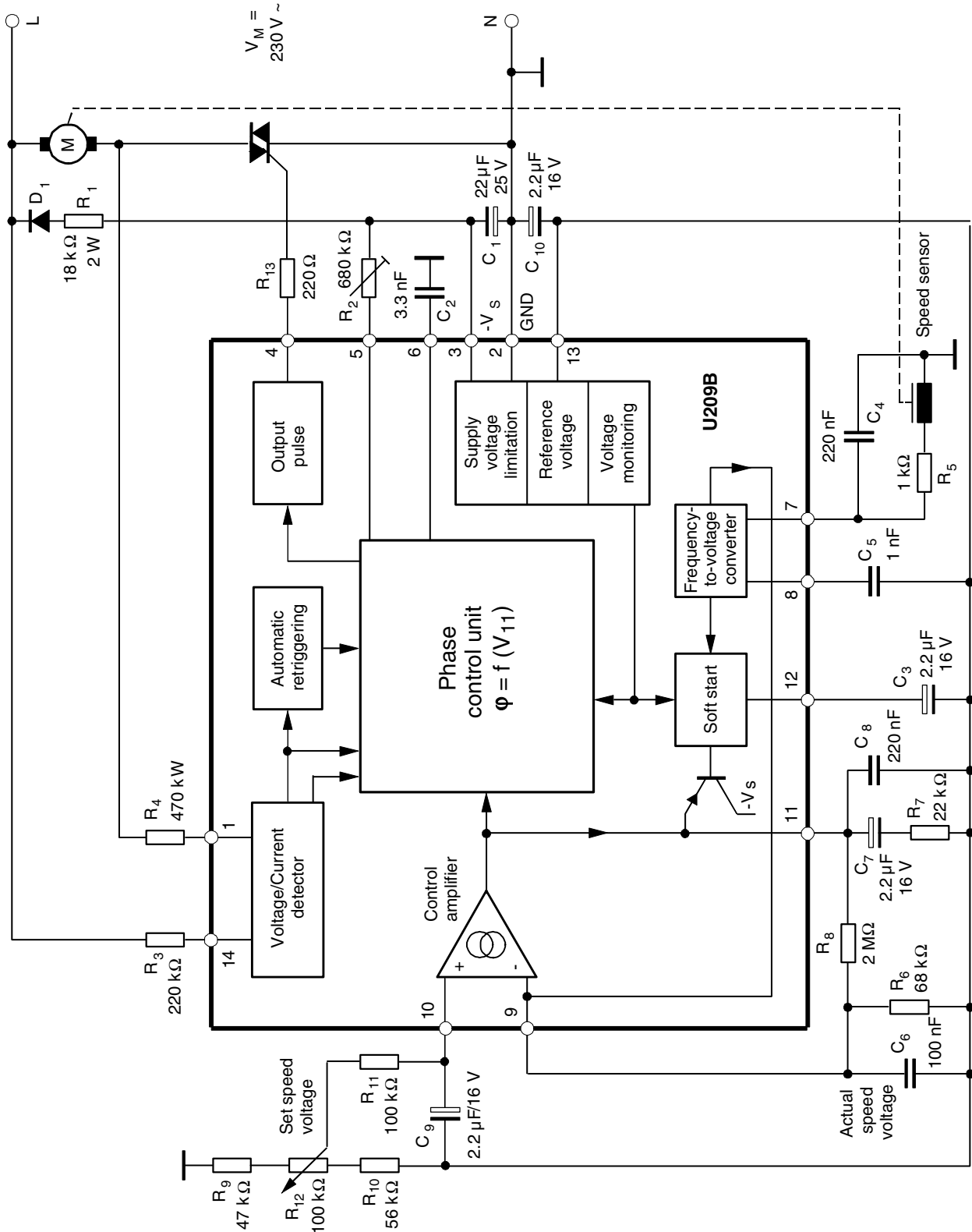
Pin numbers in brackets refer to SO16 Package

## U209B

Rev. 4765A-INDCO-01/04

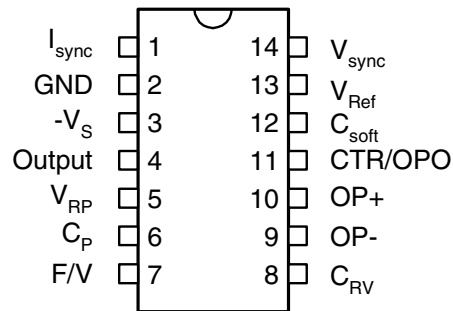


**Figure 2.** Block Diagram with Typical Circuitry for Speed Regulation



## Pin Configuration

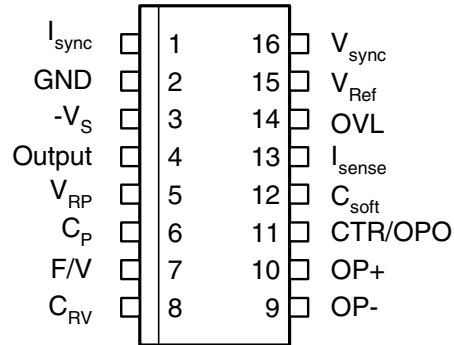
Figure 3. Pinning DIP14



## Pin Description

| Pin | Symbol     | Function                       |
|-----|------------|--------------------------------|
| 1   | $I_{sync}$ | Current synchronization        |
| 2   | GND        | Ground                         |
| 3   | $-V_S$     | Supply voltage                 |
| 4   | Output     | Trigger pulse output           |
| 5   | $V_{RP}$   | Ramp current adjust            |
| 6   | $C_P$      | Ramp voltage                   |
| 7   | F/V        | Frequency-to-voltage converter |
| 8   | $C_{RV}$   | Charge pump                    |
| 9   | OP-        | OP inverting input             |
| 10  | OP+        | OP non-inverting input         |
| 11  | CTR/OPO    | Control input/OP output        |
| 12  | $C_{soft}$ | Soft start                     |
| 13  | $V_{Ref}$  | Reference voltage              |
| 14  | $V_{sync}$ | Voltage synchronization        |

**Figure 4.** Pinning SO16



## Pin Description

| Pin | Symbol      | Function                       |
|-----|-------------|--------------------------------|
| 1   | $I_{sync}$  | Current synchronization        |
| 2   | GND         | Ground                         |
| 3   | $-V_S$      | Supply voltage                 |
| 4   | Output      | Trigger pulse output           |
| 5   | $V_{RP}$    | Ramp current adjust            |
| 6   | $C_P$       | Ramp voltage                   |
| 7   | F/V         | Frequency-to-voltage converter |
| 8   | $C_{RV}$    | Charge pump                    |
| 9   | OP-         | OP inverting input             |
| 10  | OP+         | OP non-inverting input         |
| 11  | CTR/OPO     | Control input/OP output        |
| 12  | $C_{soft}$  | Soft start                     |
| 13  | $I_{sense}$ | Load-current sensing           |
| 14  | OVL         | Overload adjust                |
| 15  | $V_{Ref}$   | Reference voltage              |
| 16  | $V_{sync}$  | Voltage synchronization        |

## Description

### Mains Supply

The U209B is equipped with voltage limiting and can therefore be supplied directly from the mains. The supply voltage between pin 2 (+ pol/⊥) and pin 3 builds up across  $D_1$  and  $R_1$ , and is smoothed by  $C_1$ . The value of the series resistance can be approximated using:

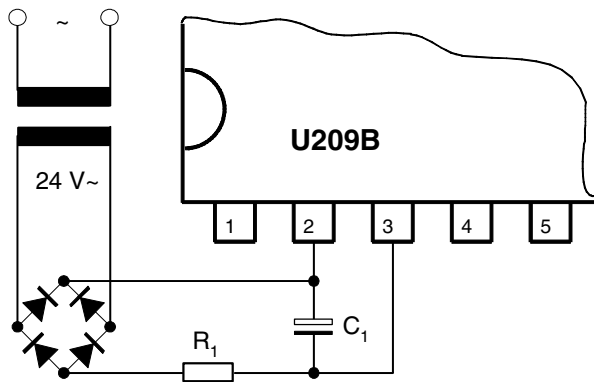
$$R_1 = \frac{V_M - V_S}{2 I_S}$$

Further information regarding the design of the mains supply can be found in the section “Design Calculations for Mains Supply” on page 9. The reference voltage source on pin 13 of typically -8.9 V is derived from the supply voltage and represents the reference level of the control unit.

Operation using an externally stabilized DC voltage is not recommended.

If the supply cannot be taken directly from the mains because the power dissipation in  $R_1$  would be too large, the circuit as shown in Figure 5 should be used.

**Figure 5.** Supply Voltage for High Current Requirements



### Phase Control

The function of the phase control is largely identical to that of the well known integrated circuit U2008B. The phase angle of the trigger pulse is derived by comparing the ramp voltage (which is mains synchronized by the voltage detector) with the set value on the control input pin 4. The slope of the ramp is determined by  $C_2$  and its charging current. The charging current can be varied using  $R_2$  on pin 5. The maximum phase angle  $\alpha_{max}$  can also be adjusted by using  $R_2$ .

When the potential on pin 6 reaches the nominal value predetermined at pin 11, a trigger pulse is generated whose width  $t_p$  is determined by the value of  $C_2$  (the value of  $C_2$  and hence the pulse width can be evaluated by assuming  $8 \mu\text{s/nF}$ ).

The current sensor on pin 1 ensures that, for operation with inductive loads, no pulse is generated in a new half cycle as long as a current from the previous half cycle is still flowing in the opposite direction to the supply voltage at that instant. This makes sure that “gaps” in the load current are prevented.

The control signal on pin 11 can be in the range 0 V to -7 V (reference point pin 2).

If  $V_{11} = -7 \text{ V}$ , the phase angle is at maximum =  $\alpha_{max}$ , i.e., the current flow angle is at minimum. The minimum phase angle  $\alpha_{min}$  is when  $V_{11} = V_{pin 2}$ .

## Voltage Monitoring

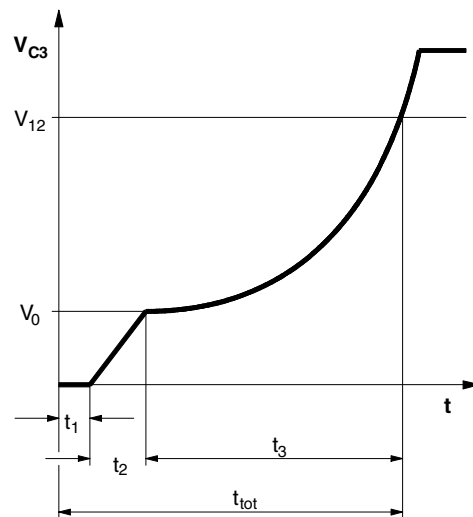
As the voltage is built up, uncontrolled output pulses are avoided by internal voltage surveillance. At the same time, all latches in the circuit (phase control, soft start) are reset and the soft-start capacitor is short-circuited. Used with a switching hysteresis of 300 mV, this system guarantees defined start-up behavior each time the supply voltage is switched on or after short interruptions of the mains supply.

## Soft Start

As soon as the supply voltage builds up ( $t_1$ ), the integrated soft start is initiated. Figure 6 shows the behavior of the voltage across the soft-start capacitor, which is identical with the voltage on the phase control input on pin 11. This behavior guarantees a gentle start-up for the motor and automatically ensures the optimum run-up time.

$C_3$  is first charged up to the starting voltage  $V_0$  with typically 30  $\mu\text{A}$  current ( $t_2$ ). By reducing the charging current to approximately 4  $\mu\text{A}$ , the slope of the charging function is also substantially reduced, so that the rotational speed of the motor only slowly increases. The charging current then increases as the voltage across  $C_3$  increases giving a progressively rising charging function which accelerates the motor with increasing rotational speed. The charging function determines the acceleration up to the set-point. The charging current can have a maximum value of 50 mA.

**Figure 6.** Soft Start



|             |   |
|-------------|---|
| $t_1$       | = build-up of supply voltage            |
| $t_2$       | = charging of $C_3$ to starting voltage |
| $t_1 + t_2$ | = dead time                             |
| $t_3$       | = run-up time                           |
| $t_{tot}$   | = total start-up time to required speed |

## Frequency-to-voltage Converter

The internal frequency-to-voltage converter (f/V converter) generates a DC signal on pin 9 which is proportional to the rotational speed, using an AC signal from a tachogenerator or a light beam whose frequency is in turn dependent on the rotational speed. The high impedance input with a switch-on threshold of typically -100 mV gives very reliable operation even when relatively simple tachogenerators are employed. The tachofrequency is given by:

$$f = \frac{n}{60} p(\text{Hz})$$

n = revolution per minute

p = number of pulses per revolution

The converter is based on the charge pumping principle. With each negative half wave of the input signal, a quantity of charge determined by  $C_5$  is internally amplified and then integrated by  $C_6$  at the converter output on pin 9. The conversion constant is determined by  $C_5$ , its charging voltage of  $V_{ch}$ ,  $R_6$  (pin 9) and the internally adjusted charge amplification  $G_i$ .

$$k = G_i \times C_5 \times R_6 \times V_{ch}$$

The analog output voltage is given by

$$\begin{aligned} V_o &= k \times f \\ \text{where: } V_{ch} &= 6.7 \text{ V} \\ G_i &= 8.3 \end{aligned}$$

The values of  $C_5$  and  $C_6$  must be such that for the highest possible input frequency, the maximum output voltage  $V_o$  does not exceed 6 V. The  $R_i$  on pin 8 is approximately 6 k $\Omega$  while  $C_5$  is charging up. To obtain good linearity of the f/V converter the time constant resulting from  $R_i$  and  $C_5$  should be considerably less (1/5) than the time span of the negative half cycle for the highest possible input frequency. The amount of remaining ripple on the output voltage on pin 9 is dependent on  $C_5$ ,  $C_6$  and the internal charge amplification.

$$\Delta V_o = \frac{G_i \times V_{ch} \times C_5}{C_6}$$

The ripple  $\Delta V_o$  can be reduced by using larger values of  $C_6$ , however, the maximum conversion speed will then also be reduced.

The value of this capacitor should be chosen to fit the particular control loop where it is going to be used.

## Control Amplifier

The integrated control amplifier with differential input compares the set value (pin 10) with the instantaneous value on pin 9, and generates a regulating voltage on the output pin 11 (together with external circuitry on pin 12). This pin always tries to keep the real voltage at the value of the set voltages. The amplifier has a transmittance of typically 110  $\mu\text{A/V}$  and a bipolar current source output on pin 11 which operates with typically  $\pm 100 \mu\text{A}$ . The amplification and frequency response are determined by  $R_7$ ,  $C_7$ ,  $C_8$  and  $R_8$  (can be left out). For operation as a power divider,  $C_4$ ,  $C_5$ ,  $R_6$ ,  $C_6$ ,  $R_7$ ,  $C_7$ ,  $C_8$  and  $R_8$  can be left out. Pin 9 should be connected with pin 11 and pin 7 with pin 2. The phase angle of the triggering pulse can be adjusted using the voltage on pin 10. An internal limiting circuit prevents the voltage on pin 11 from becoming more negative than  $V_{13} + 1 \text{ V}$ .

## Pulse-output Stage

The pulse-output stage is short-circuit protected and can typically deliver currents of 125 mA. For the design of smaller triggering currents, the function  $I_{GT} = f(R_{GT})$  can be taken from Figure 15 on page 15.

## Automatic Retriggering

The automatic retriggering prevents half cycles without current flow, even if the triacs have been turned off earlier, e.g., due to not exactly centered collector (brush lifter) or in the event of unsuccessful triggering. If necessary, another triggering pulse is generated after a time lapse of  $t_{pp} = 4.5 t_p$  and this is repeated until either the triac fires or the half cycle finishes.

## General Hints and Explanation of Terms

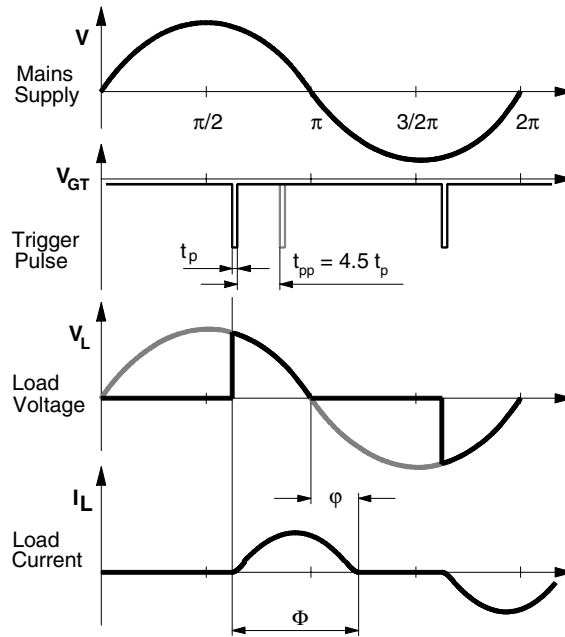
To ensure safe and trouble-free operation, the following points should be taken into consideration when circuits are being constructed or in the design of printed circuit boards.

The connecting lines from  $C_2$  to pin 6 and pin 2 should be as short as possible, and the connection to pin 2 should not carry any additional high current such as the load current. When selecting  $C_2$ , a low temperature coefficient is desirable.

The common (earth) connections of the set-point generator, the tachometer generator and the final interference suppression capacitor  $C_4$  of the f/V converter should not carry load current.

The tachometer generator should be mounted without influence by strong stray fields from the motor.

**Figure 7.** Explanation of Terms in Phase Relationship





## Design Calculations for Mains Supply

The following equations can be used for the evaluation of the series resistor  $R_1$  for worst case conditions:

$$R_{1\max} = 0.85 \frac{V_{M\min} - V_{S\max}}{2 I_{\text{tot}}}$$

$$R_{1\min} = \frac{V_M - V_{S\min}}{2 I_{S\max}}$$

$$P_{(R1\max)} = \frac{(V_{M\max} - V_{S\min})^2}{2 R_1}$$

where:

$V_M$  = Mains voltage 230 V

$V_S$  = Supply voltage on pin 3

$I_{\text{tot}}$  = Total DC current requirement of the circuit

$$= I_S + I_p + I_x$$

$I_{S\max}$  = Current requirement of the IC in mA

$I_p$  = Average current requirement of the triggering pulse

$I_x$  = Current requirement of other peripheral components

$R_1$  can be easily evaluated from Figure 17 on page 16 to Figure 19 on page 16.

## Absolute Maximum Ratings

Stresses beyond those listed under “Absolute Maximum Ratings” may cause permanent damage to the device. This is a stress rating only and functional operation of the device at these or any other conditions beyond those indicated in the operational sections of this specification is not implied. Exposure to absolute maximum rating conditions for extended periods may affect device reliability.

Reference point pin 2, unless otherwise specified

| Parameters                          | Pins | Symbol             | Value           | Unit             |
|-------------------------------------|------|--------------------|-----------------|------------------|
| Current requirement                 | 3    | $-I_S$             | 30              | mA               |
| $t \leq 10 \mu\text{s}$             | 3    | $-i_s$             | 100             | mA               |
| Synchronization current             | 1    | $I_{\text{syncI}}$ | 5               | mA               |
|                                     | 14   | $I_{\text{syncV}}$ | 5               | mA               |
| $t < 10 \mu\text{s}$                | 1    | $\pm i_I$          | 35              | mA               |
| $t < 10 \mu\text{s}$                | 14   | $\pm i_V$          | 35              | mA               |
| <b>f/V Converter</b>                |      |                    |                 |                  |
| Input current                       | 7    | $I_{\text{eff}}$   | 3               | mA               |
| $t < 10 \mu\text{s}$                | 7    | $\pm i_i$          | 13              | mA               |
| <b>Phase Control</b>                |      |                    |                 |                  |
| Input voltage                       | 11   | $-V_I$             | 0 to 7          | V                |
| Input current                       | 11   | $\pm i_I$          | 500             | $\mu\text{A}$    |
| <b>Soft Start</b>                   |      |                    |                 |                  |
| Input voltage                       | 12   | $-V_I$             | $ V_{13} $ to 0 | V                |
| <b>Pulse Output</b>                 |      |                    |                 |                  |
| Reverse voltage                     | 4    | $V_R$              | $V_S$ to 5      | V                |
| <b>Amplifier</b>                    |      |                    |                 |                  |
| Input voltage                       | 10   | $-V_I$             | $ V_S $         |                  |
| Pin 8 open                          | 9    | $-V_I$             | $ V_{13} $ to 0 | V                |
| <b>Reference Voltage Source</b>     |      |                    |                 |                  |
| Output current                      | 13   | $I_o$              | 7.5             | mA               |
| Power dissipation                   |      | $P_{\text{tot}}$   | 570             | mW               |
| $T_{\text{amb}} = 45^\circ\text{C}$ |      | $P_{\text{tot}}$   | 320             | mW               |
| $T_{\text{amb}} = 80^\circ\text{C}$ |      |                    |                 |                  |
| Storage temperature range           |      | $T_{\text{stg}}$   | -40 to +125     | $^\circ\text{C}$ |
| Junction temperature                |      | $T_j$              | 125             | $^\circ\text{C}$ |
| Ambient temperature range           |      | $T_{\text{amb}}$   | -10 to +100     | $^\circ\text{C}$ |

## Thermal Resistance

| Parameters                | Symbol            | Value | Unit |
|---------------------------|-------------------|-------|------|
| Junction ambient          | $R_{\text{thJA}}$ | 140   | K/W  |
| DIP14                     | $R_{\text{thJA}}$ | 180   | K/W  |
| SO16 on p.c. board        | $R_{\text{thJA}}$ | 100   | K/W  |
| SO16 on ceramic substrate | $R_{\text{thJA}}$ |       |      |

## Electrical Characteristics

$-V_S = 13.0\text{ V}$ ,  $T_{\text{amb}} = 25^\circ\text{C}$ , reference point pin 2, unless otherwise specified

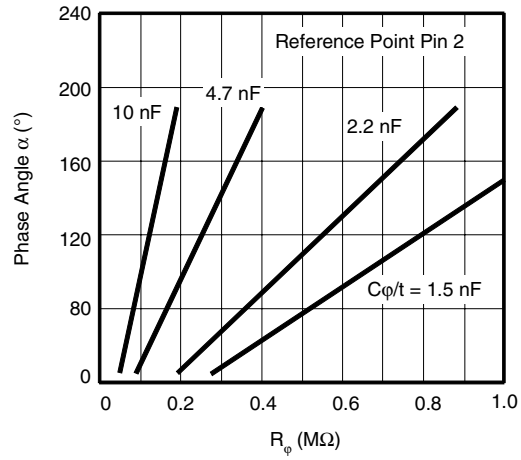
| Parameters                                      | Test Conditions  | Pins  | Symbol                    | Min.                    | Typ. | Max.                 | Unit             |
|---|--|-------|---------------------------|-------------------------|------|----------------------|------------------|
| Supply voltage for mains operation              |  | 3     | $-V_S$                    | 13.0                    |      | $V_{\text{Limit}}$   | V                |
| Supply voltage limitation                       | $-I_S = 3\text{ mA}$   | 3     | $-V_S$                    | 14.6                    |      | 16.6                 | V                |
|   | $-I_S = 30\text{ mA}$  |       |                           | 14.7                    |      | 16.8                 | V                |
| DC supply current                               | $-V_S = 13.0\text{ V}$   | 3     | $-I_S$                    | 1.1                     | 2.5  | 3.0                  | mA               |
| Reference voltage source                        | $-I_L = 10\text{ }\mu\text{A}$                                     | 13    | $V_{\text{Ref}}$          | 8.6                     | 8.9  | 9.2                  | V                |
|   | $-I_L = 5\text{ mA}$   |       |                           | 8.3                     |      | 9.1                  | V                |
| Temperature coefficient                         |  | 13    | $TC_{V_{\text{Ref}}}$     |                         |      | 0.5                  | mV/K             |
| <b>Voltage Monitoring</b>                       |  |       |                           |                         |      |                      |                  |
| Turn-on threshold                               |  | 3     | $-V_{\text{TON}}$         |                         | 11.2 | 13                   | V                |
| Turn-off threshold                              |  | 3     | $-V_{\text{TOFF}}$        | 9.9                     | 10.9 |                      | V                |
| <b>Phase-control Currents</b>                   |  |       |                           |                         |      |                      |                  |
| Current synchronization                         |  | 1     | $\pm I_{\text{syncI}}$    | 0.35                    |      | 2.0                  | mA               |
| Voltage synchronization                         |  | 14    | $\pm I_{\text{syncV}}$    | 0.35                    |      | 2.0                  | mA               |
| Voltage limitation                              | $\pm I_L = 5\text{ mA}$  | 1, 14 | $\pm V_I$                 | 1.4                     | 1.6  | 1.8                  | V                |
| <b>Reference Ramp (see Figure 8 on page 13)</b> |  |       |                           |                         |      |                      |                  |
| Charge current                                  | $I_6 = f(R_5)$<br>$R_5 = 1\text{ k}\Omega$ to $820\text{ k}\Omega$ | 6     | $I_6$                     | 1                       |      | 20                   | $\mu\text{A}$    |
| R $\phi$ -reference voltage                     | $\alpha \geq 180^\circ$  | 5, 3  | $V_{\phi\text{Ref}}$      | 1.06                    | 1.13 | 1.18                 | V                |
| Temperature coefficient                         |  | 5     | $TC_{V_{\phi\text{Ref}}}$ |                         | 0.5  |                      | mV/K             |
| <b>Output Pulse</b>                             |  |       |                           |                         |      |                      |                  |
| Output pulse current                            | $R_V = 0$ , $V_{\text{GT}} = 1.2\text{ V}$                         | 4     | $I_O$                     | 100                     | 155  | 190                  | mA               |
| Reverse current                                 |  | 4     | $I_{\text{OR}}$           |                         | 0.01 | 3.0                  | $\mu\text{A}$    |
| Output pulse width                              |  | 5, 2  | $t_p$                     |                         | 8    |                      | $\mu\text{s/nF}$ |
| <b>Automatic Retriggering</b>                   |  |       |                           |                         |      |                      |                  |
| Repetition rate                                 |  | 4     | $t_{\text{pp}}$           | 3                       | 4.5  | 6                    | $t_p$            |
| <b>Amplifier</b>                                |  |       |                           |                         |      |                      |                  |
| Common-mode signal range                        |  | 9, 10 | $V_{\text{ICR}}$          | $(V_{13} - 1\text{ V})$ |      | $(V_2 - 1\text{ V})$ | V                |
| Input bias current                              |  | 10    | $I_{\text{IB}}$           |                         | 0.01 | 1                    | mA               |
| Input offset voltage                            |  | 9, 10 | $V_{\text{IO}}$           |                         | 10   |                      | mV               |
| Output current                                  |  | 11    | $-I_O$<br>$+I_O$          | 75                      | 110  | 145                  | $\mu\text{A}$    |
|   |  |       |                           | 88                      | 120  | 165                  | $\mu\text{A}$    |
| Short circuit forward, transmittance            | $I_{11} = f(V_{9/10})$   | 11    | $Y_f$                     |                         | 1000 |                      | $\mu\text{A/V}$  |

## Electrical Characteristics (Continued)

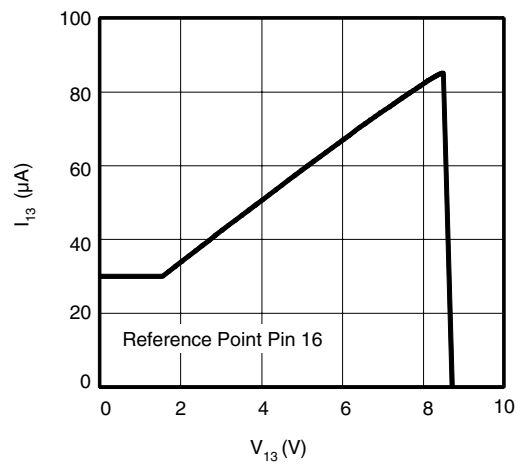
$-V_S = 13.0\text{ V}$ ,  $T_{\text{amb}} = 25^\circ\text{C}$ , reference point pin 2, unless otherwise specified

| Parameters  | Test Conditions  | Pins | Symbol                             | Min.        | Typ.    | Max.        | Unit          |
|---|--|------|------------------------------------|-------------|---------|-------------|---------------|
| <b>Frequency-to-voltage Converter</b>   |  |      |                                    |             |         |             |               |
| Input bias current  |  | 7    | $I_{\text{IB}}$                    |             | 0.6     | 2           | $\mu\text{A}$ |
| Input voltage limitation  | $\pm I_{\text{I}} = -1\text{ mA}$                                  | 7    | $-V_{\text{I}}$<br>$+V_{\text{I}}$ | 660<br>7.25 |         | 750<br>8.05 | mV<br>V       |
| Turn-on threshold   |  | 7    | $-V_{\text{TON}}$                  |             | 100     | 150         | mV            |
| Turn-off threshold  |  | 7    | $-V_{\text{TOFF}}$                 | 20          | 50      |             | mV            |
| Discharge current   | (see Figure 2 on page 2)   | 8    | $I_{\text{dis}}$                   |             | 0.5     |             | mA            |
| Charge transfer voltage   |  | 8    | $V_{\text{ch}}$                    | 6.50        | 6.70    | 6.90        | V             |
| Charge transfer gain  | $I_{\text{g}}/I_{\text{g}}$  | 8, 9 | $G_{\text{i}}$                     | 7.5         | 8.3     | 9.0         |               |
| Conversion factor   | $C_{\text{g}} = 1\text{ nF}$ , $R_{\text{g}} = 100\text{ k}\Omega$ |      | k                                  |             | 5.5     |             | mV/Hz         |
| Output operating range  | f/V output, reference point pin 13                                 | 9    | $V_{\text{O}}$                     |             | 0-6     |             | V             |
| Linearity   |  |      |                                    |             | $\pm 1$ |             | %             |
| <b>Soft Start, f/V Converter Non-active (see Figure 10 on page 13 and Figure 11 on page 14)</b> |  |      |                                    |             |         |             |               |
| Starting current  | $V_{12} = V_{13}$ , $V_7 = V_2$                                    | 12   | $I_{\text{O}}$                     | 20          | 30      | 50          | $\mu\text{A}$ |
| Final current   | $V_{12} = -0.5\text{ V}$   | 12   | $I_{\text{O}}$                     | 50          | 85      | 130         | $\mu\text{A}$ |
| <b>Soft Start, f/V Converter Active (see Figure 9 on page 13, Figure 12 on page 14)</b>         |  |      |                                    |             |         |             |               |
| Starting current  | $V_{12} = V_{13}$  | 12   | $I_{\text{O}}$                     | 2           | 4       | 6           | $\mu\text{A}$ |
| Final current   | $V_{12} = -0.5\text{ V}$   | 12   | $I_{\text{O}}$                     | 30          | 55      | 80          | $\mu\text{A}$ |
| Discharge current   | Restart pulse  | 12   | $-I_{\text{O}}$                    | 0.5         | 3       | 10          | mA            |

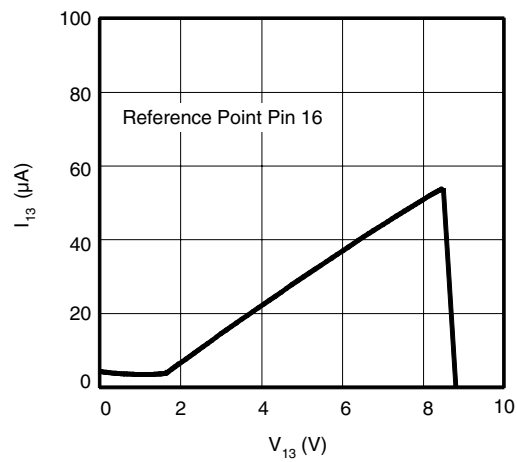
**Figure 8. Ramp Control**



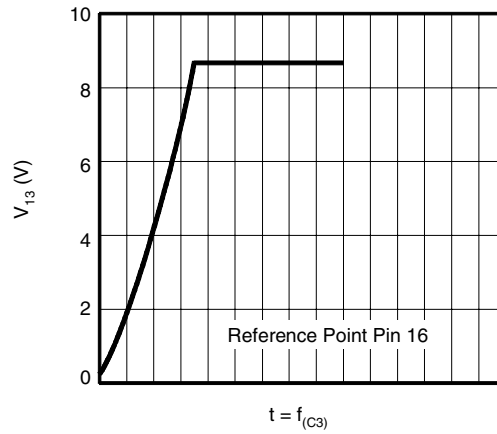
**Figure 9. Soft-start Charge Current (f/V Converter Active)**



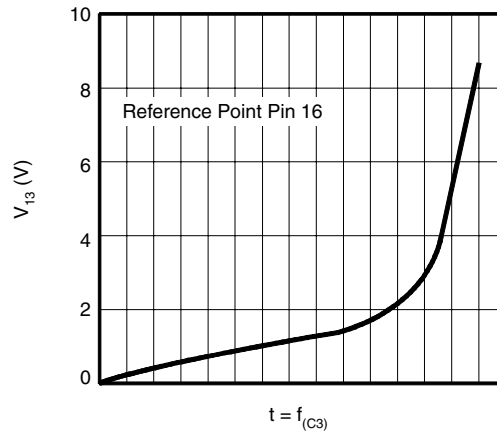
**Figure 10. Soft-start Charge Current (f/V Converter Non-active)**



**Figure 11. Soft-start Voltage (f/V Converter Non-active)**



**Figure 12. Soft-start Voltage (f/V Converter Active)**



**Figure 13. f/V Converter Voltage Limitation**

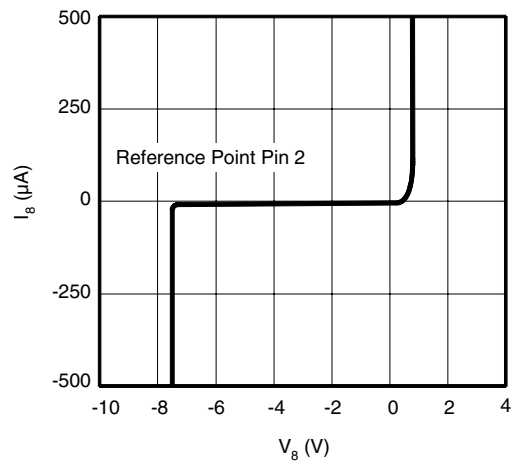


Figure 14. Soft-start Function

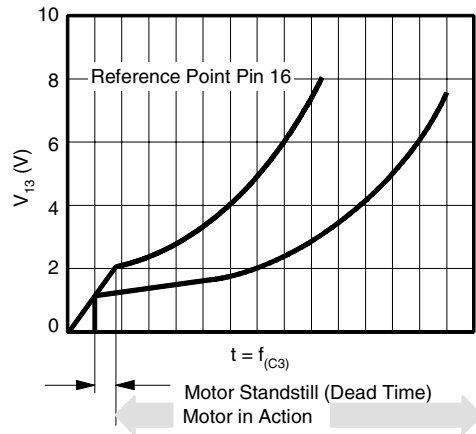


Figure 15. Amplifier Output Characteristics

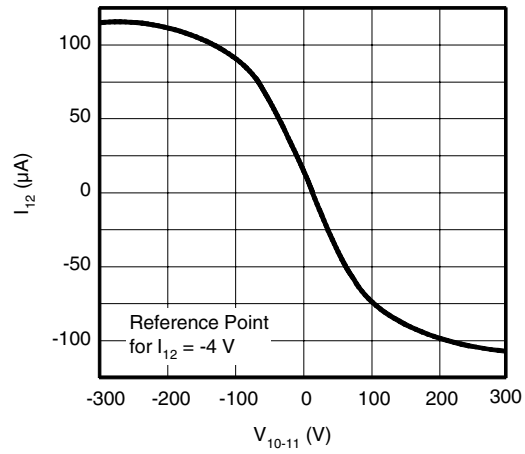
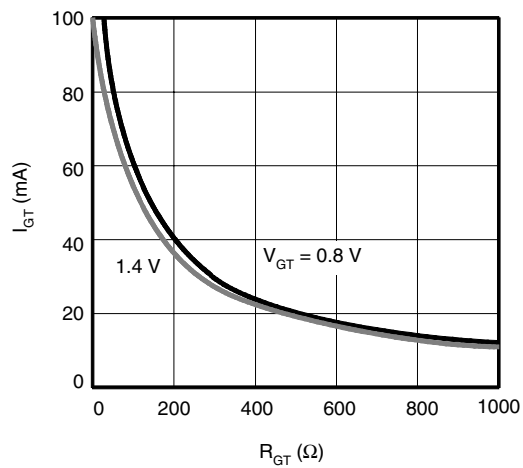
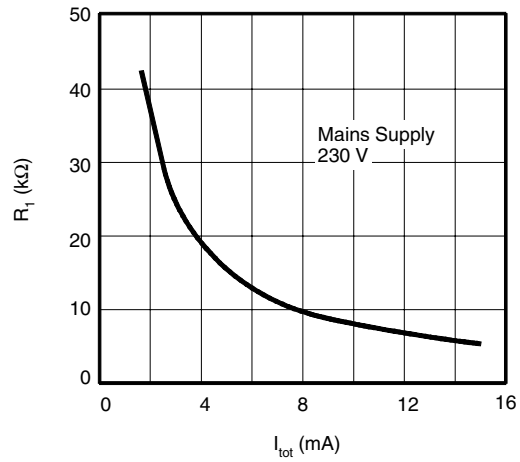


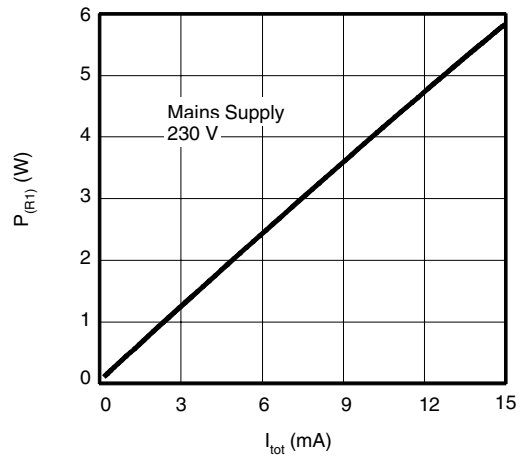
Figure 16. Pulse Output



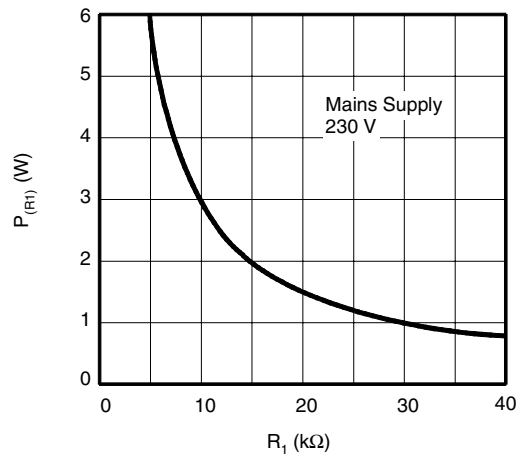
**Figure 17.** Determination of  $R_1$



**Figure 18.** Power Dissipation of  $R_1$  According to Current Consumption



**Figure 19.** Power Dissipation of  $R_1$





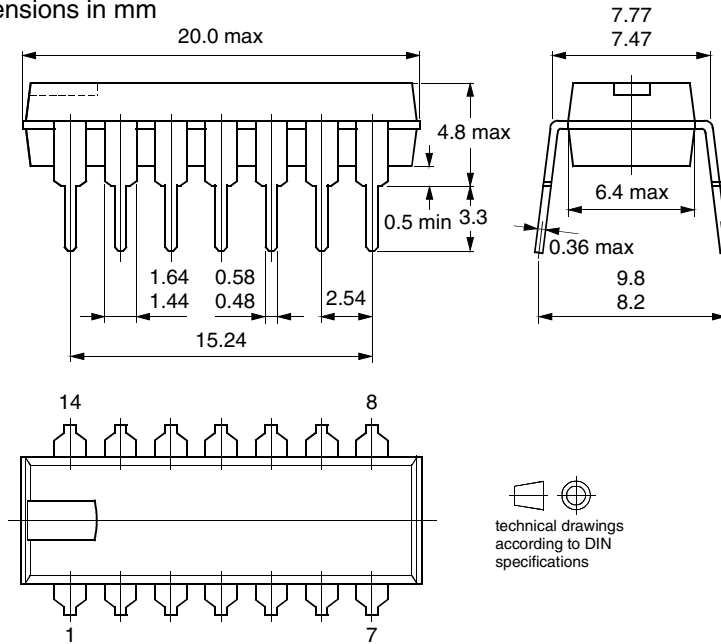
### Ordering Information

| Extended Type Number | Package | Remarks          |
|----------------------|---------|------------------|
| U209B-x              | DIP14   | Tube             |
| U209B-xFP            | SO16    | Tube             |
| U209B-xFPG3          | SO16    | Taped and reeled |

### Package Information

#### Package DIP14

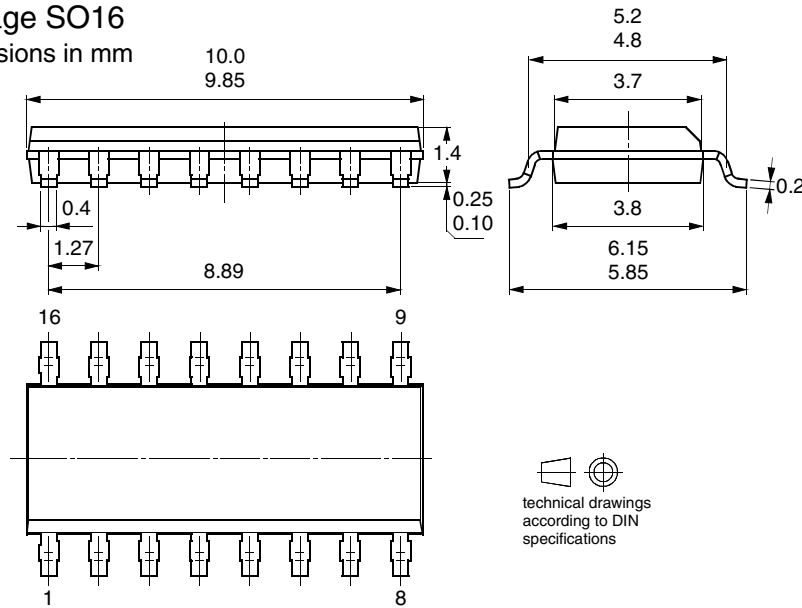
Dimensions in mm



technical drawings according to DIN specifications

#### Package SO16

Dimensions in mm



technical drawings according to DIN specifications



## Atmel Corporation

2325 Orchard Parkway  
San Jose, CA 95131, USA  
Tel: 1(408) 441-0311  
Fax: 1(408) 487-2600

## Regional Headquarters

### Europe

Atmel Sarl  
Route des Arsenalux 41  
Case Postale 80  
CH-1705 Fribourg  
Switzerland  
Tel: (41) 26-426-5555  
Fax: (41) 26-426-5500

### Asia

Room 1219  
Chinachem Golden Plaza  
77 Mody Road Tsimshatsui  
East Kowloon  
Hong Kong  
Tel: (852) 2721-9778  
Fax: (852) 2722-1369

### Japan

9F, Tonetsu Shinkawa Bldg.  
1-24-8 Shinkawa  
Chuo-ku, Tokyo 104-0033  
Japan  
Tel: (81) 3-3523-3551  
Fax: (81) 3-3523-7581

## Atmel Operations

### Memory

2325 Orchard Parkway  
San Jose, CA 95131, USA  
Tel: 1(408) 441-0311  
Fax: 1(408) 436-4314

### Microcontrollers

2325 Orchard Parkway  
San Jose, CA 95131, USA  
Tel: 1(408) 441-0311  
Fax: 1(408) 436-4314

La Chantrerie  
BP 70602  
44306 Nantes Cedex 3, France  
Tel: (33) 2-40-18-18-18  
Fax: (33) 2-40-18-19-60

### ASIC/ASSP/Smart Cards

Zone Industrielle  
13106 Rousset Cedex, France  
Tel: (33) 4-42-53-60-00  
Fax: (33) 4-42-53-60-01

1150 East Cheyenne Mtn. Blvd.  
Colorado Springs, CO 80906, USA  
Tel: 1(719) 576-3300  
Fax: 1(719) 540-1759

Scottish Enterprise Technology Park  
Maxwell Building  
East Kilbride G75 0QR, Scotland  
Tel: (44) 1355-803-000  
Fax: (44) 1355-242-743

### RF/Automotive

Theresienstrasse 2  
Postfach 3535  
74025 Heilbronn, Germany  
Tel: (49) 71-31-67-0  
Fax: (49) 71-31-67-2340

1150 East Cheyenne Mtn. Blvd.  
Colorado Springs, CO 80906, USA  
Tel: 1(719) 576-3300  
Fax: 1(719) 540-1759

### Biometrics/Imaging/Hi-Rel MPU/ High Speed Converters/RF Datacom

Avenue de Rochepleine  
BP 123  
38521 Saint-Egreve Cedex, France  
Tel: (33) 4-76-58-30-00  
Fax: (33) 4-76-58-34-80

---

### Literature Requests

[www.atmel.com/literature](http://www.atmel.com/literature)

**Disclaimer:** Atmel Corporation makes no warranty for the use of its products, other than those expressly contained in the Company's standard warranty which is detailed in Atmel's Terms and Conditions located on the Company's web site. The Company assumes no responsibility for any errors which may appear in this document, reserves the right to change devices or specifications detailed herein at any time without notice, and does not make any commitment to update the information contained herein. No licenses to patents or other intellectual property of Atmel are granted by the Company in connection with the sale of Atmel products, expressly or by implication. Atmel's products are not authorized for use as critical components in life support devices or systems.

© Atmel Corporation 2004. All rights reserved.

Atmel® and combinations thereof are the registered trademarks of Atmel Corporation or its subsidiaries.

Other terms and product names may be the trademarks of others.



Printed on recycled paper.

4765A-INDCO-01/04