

P	LTR	DESCRIPTION	DATE	DWN	APVD
	D	REDRAWN & REV PER EC 0020-680-93	14 AUG 97	-	KD
	E	ADDED -2 PER EC 0320-273-97	14 AUG 97	-	KD
	E1	REVISED PER ECO-19-001991	09FEB2019	RS	MZ

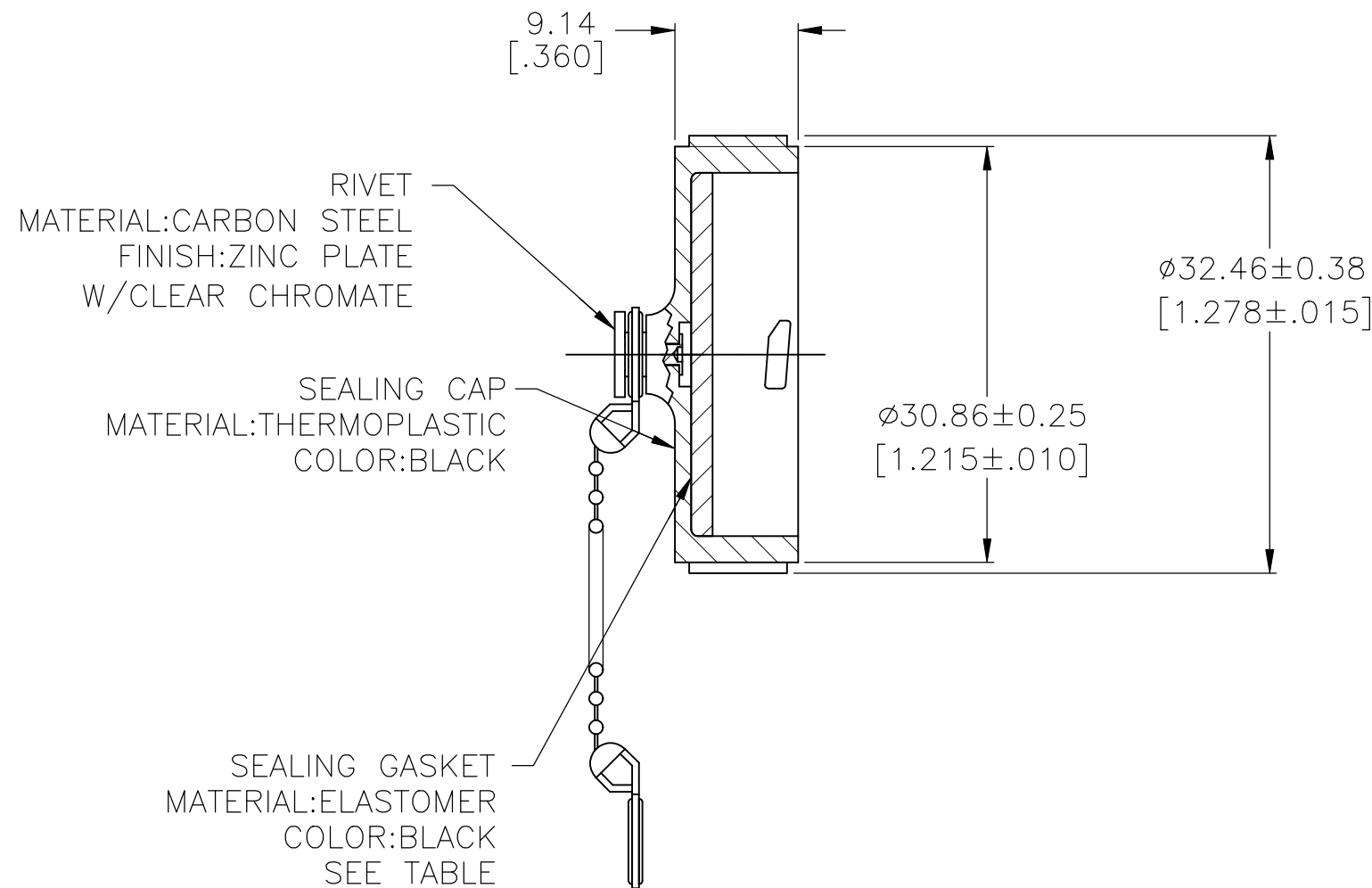
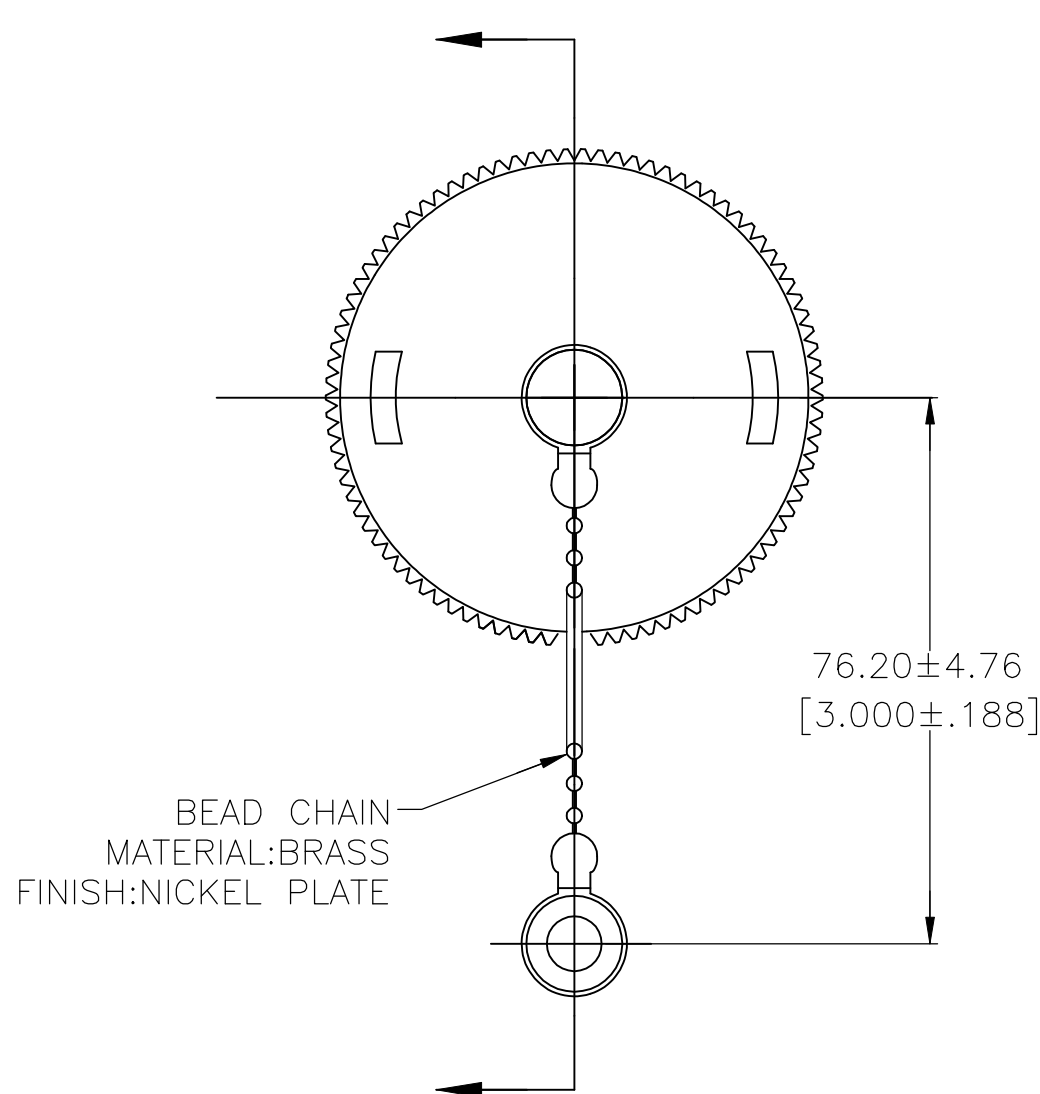

NO	208652-2
YES	208652-1
SEALING GASKET	PART NUMBER

THIS DRAWING IS A CONTROLLED DOCUMENT.		DWN D.BROCKWAY 6-10-93	STE TE Connectivity	
		CHK R.STONE 7-1-93		
DIMENSIONS: mm [INCHES]	TOLERANCES UNLESS OTHERWISE SPECIFIED:	APVD AL FRANTUM 7-1-93 7-1-93	NAME SEALING CAP ASSY, SIZE 17, WITH BEAD CHAIN, CPC	
	0 PLC ± - 1 PLC ± - 2 PLC ± 0.13[.005] 3 PLC ± - 4 PLC ± - ANGLES ± -	PRODUCT SPEC -	APPLICATION SPEC -	
MATERIAL SEE CALLOUTS	FINISH SEE CALLOUTS	WEIGHT -	SIZE A3	CAGE CODE 00779
		DRAWING NO C-208652		RESTRICTED TO -
		CUSTOMER DRAWING		SCALE 2:1
		SHEET 1 OF 1		REV E1