



A Product Line of  
Diodes Incorporated



# SPECIFICATION FOR APPROVAL

CUSTOMER \_\_\_\_\_

NOMINAL FREQUENCY 12.000000 MHz

PRODUCT TYPE TYPE GC 49S SMD QUARTZ CRYSTAL

SPEC. NO. ( P/N ) GC1200039

CUSTOMER P/N \_\_\_\_\_

ISSUE DATE September 22, 2017

VERSION D

APPROVED	PREPARED	QA

## Diodes Incorporation

No.2, Ziqiang 5th Rd., Zhongli Industrial Park,  
Zhongli Dist., Taoyuan City 32063, Taiwan (R.O.C.)  
TEL: 886-3-451-8888  
FAX: 886-3-461-3865  
<http://www.diodes.com>

- \*RoHS Compliant
- \*HF-Halogen Free
- \*REACH Compliant

# TYPE GC 49S SMD QUARTZ CRYSTAL

**GC1200039**

VER. D 22-Sep-17

## VERSION HISTORY

Version No.	Version Date	Customer Receipt Date	Supplier Receipt Date	Description	Notes
A	Jul.16,2008			Initial Release	
B	Jul.22,2010			New Logo	
C	Aug.30,2011			Updated Suggested IR Reflow Profile & Format	
D	Sep.22,2017			Updated Logo	



# TYPE GC 49S SMD QUARTZ CRYSTAL

## GC1200039

VER. D 22-Sep-17

### ELECTRICAL SPECIFICATIONS

Item	Symbol	Specifications	Units	Notes
Nominal Frequency	Fn	12.000000	MHz	
Mode of Oscillation	MO	AT Cut-Fundamental		
Calibration Load Capacitance	CL	20	pF	
Calibration Tolerance	FL	±30	ppm	at 25°C±3°C
Operating Temperature Range	TR	-20 to +70	°C	
Frequency Stability (Frequency Deviation over the Operating Temperature Range)	F/T	±30	ppm	Reference to the Frequency at 25°C
Operating Drive Level		100	μW	
Equivalent Series Resistance	ESR	40	Ω	Max
Shunt Capacitance	C0	5	pF	Max
Aging at 25°C		±3	ppm	Max, 1st year
Storage Temperature		-55 to +125	°C	
Insulation Resistance		500	MΩ	Min

# TYPE GC 49S SMD QUARTZ CRYSTAL

**GC1200039**

VER. D 22-Sep-17

## RELIABILITY SPECIFICATIONS

### MECHANICAL AND ENVIRONMENTAL RATINGS:

- a) FINE LEAK TEST: JESD22-A109 (Condition 1A)
- b) GROSS LEAK TEST: JESD22-A109 (Condition C)
- c) MOISTURE RESISTANCE: JESD22-A113
- d) SHOCK: JESD22-B104 (Condition B)
- e) SOLDERABILITY : (RoHS version): J-STD-002
- f) VIBRATION: JESD22-B103
- g) SOLVENT RESISTANCE: JESD22-B107
- h) RESISTANCE TO SOLDERING HEAT (RoHS version): J-STD-020D Table 5.2 Pb free devices (3 cycles max)

## SUGGESTED IR REFLOW PROFILE

\*As per IPC-JEDEC J-STD-020D

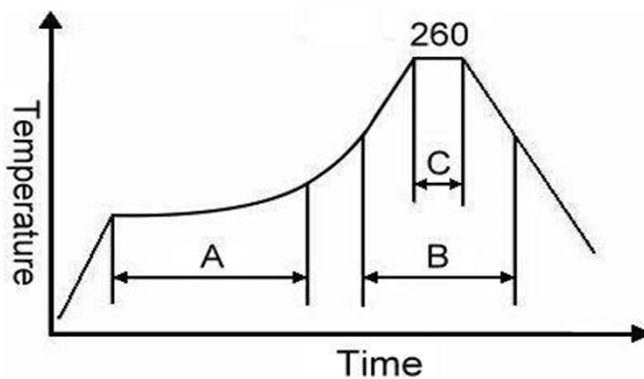

Note:

	Stage	Temperature	Time
A	Preheat	150~200°C	60~120 Sec
B	Primary Heat	217°C	60~150 Sec
C	Peak	260°C	10 Sec

# TYPE GC 49S SMD QUARTZ CRYSTAL

GC1200039

VER. D 22-Sep-17

## MARKING

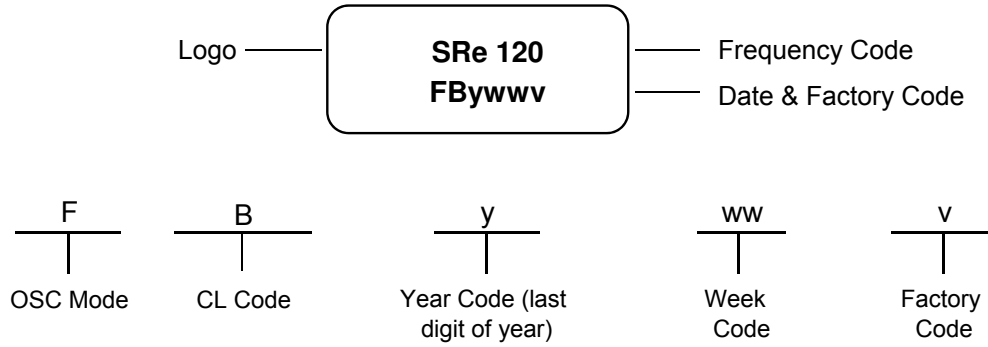

## MECHANICAL DRAWINGS ( Scale: None. Dimensions are in mm.)

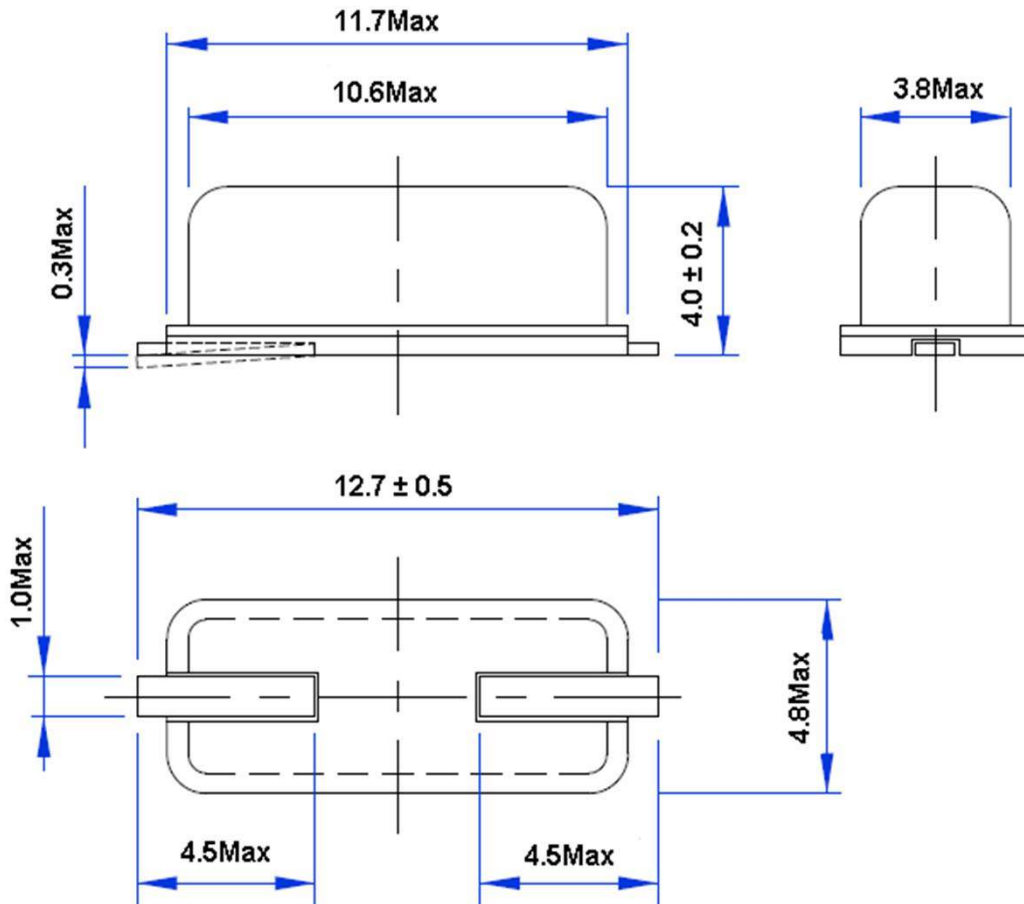

# TYPE GC 49S SMD QUARTZ CRYSTAL

GC1200039

VER. D 22-Sep-17

## PACKING

