

# Technical Information

## iTHERM TM402

Resistance thermometer for hygienic and aseptic applications

Imperial version with basic technology  
for all standard applications, permanent insert



### Applications

- Specially designed for use in hygienic and aseptic applications in the Food & Beverages and Life Sciences industries
- Measuring range:  $-50$  to  $+200$  °C ( $-58$  to  $+392$  °F)
- Pressure range up to 40 bar (580 psi)
- Protection class: up to IP69K
- Can be used in non-hazardous areas

### Temperature transmitter

All Endress+Hauser transmitters are available with enhanced accuracy and reliability compared to directly wired sensors. Easy customizing by choosing one of the following outputs and communication protocols:

- Analog output 4 to 20 mA, HART®
- Bluetooth® connectivity (optional)

### Your benefits

- Best price-performance ratio and fast delivery time
- User-friendly and reliable from product selection to maintenance
- International certification: hygiene standards as per 3-A, EHEDG, ASME BPE, FDA, TSE Certificate of Suitability
- Wide range of process connections
- Sensor assembly TM402 meets PMO requirements by US FDA for dairies

## Table of contents

<b>Function and system design</b> . . . . .	<b>3</b>	<b>Certificates and approvals</b> . . . . .	<b>20</b>
iTHERM Hygiene line . . . . .	3	Hygiene standard . . . . .	20
Measuring principle . . . . .	3	Materials in contact with food/product (FCM) . . . . .	20
Measuring system . . . . .	4	Other standards and guidelines . . . . .	21
<b>Input</b> . . . . .	<b>5</b>	Material resistance . . . . .	21
Measured variable . . . . .	5	Surface purity . . . . .	21
Measuring range . . . . .	5	<b>Ordering information</b> . . . . .	<b>21</b>
<b>Output</b> . . . . .	<b>5</b>	<b>Accessories</b> . . . . .	<b>22</b>
Output signal . . . . .	5	Device-specific accessories . . . . .	22
Family of temperature transmitters . . . . .	5	Communication-specific accessories . . . . .	22
<b>Wiring</b> . . . . .	<b>6</b>	Service-specific accessories . . . . .	23
Wiring diagrams for RTD . . . . .	6	System components . . . . .	24
Cable entries . . . . .	7	<b>Supplementary documentation</b> . . . . .	<b>24</b>
Connector . . . . .	7		
Overvoltage protection . . . . .	8		
<b>Performance characteristics</b> . . . . .	<b>8</b>		
Reference conditions . . . . .	8		
Maximum measured error . . . . .	8		
Influence of ambient temperature . . . . .	9		
Self heating . . . . .	9		
Response time . . . . .	9		
Calibration . . . . .	10		
Insulation resistance . . . . .	10		
<b>Installation</b> . . . . .	<b>10</b>		
Orientation . . . . .	10		
Installation instructions . . . . .	10		
<b>Environment</b> . . . . .	<b>13</b>		
Ambient temperature range . . . . .	13		
Storage temperature . . . . .	13		
Humidity . . . . .	13		
Climate class . . . . .	13		
Degree of protection . . . . .	13		
Shock and vibration resistance . . . . .	13		
Electromagnetic compatibility (EMC) . . . . .	13		
<b>Process</b> . . . . .	<b>13</b>		
Process temperature range . . . . .	13		
Thermal shock . . . . .	14		
Process pressure range . . . . .	14		
Medium - state of aggregation . . . . .	14		
<b>Mechanical construction</b> . . . . .	<b>15</b>		
Design, dimensions . . . . .	15		
Weight . . . . .	15		
Material . . . . .	15		
Surface roughness . . . . .	16		
Terminal heads . . . . .	16		
Process connections . . . . .	18		
Tip shape . . . . .	19		

## Function and system design

### iTHERM Hygiene line

This thermometer is part of the product line of modular thermometers for hygienic and aseptic applications.

*Differentiating factors when selecting a suitable thermometer*

TM4x1	TM4x2
Metric version	Imperial version



TM41x characterizes the device that uses cutting-edge technology, with features such as a replaceable insert, quick-fastening extension neck (iTHERM QuickNeck), vibration-resistant and fast-response sensor technology (iTHERM StrongSens and QuickSens) and approval for use in hazardous areas

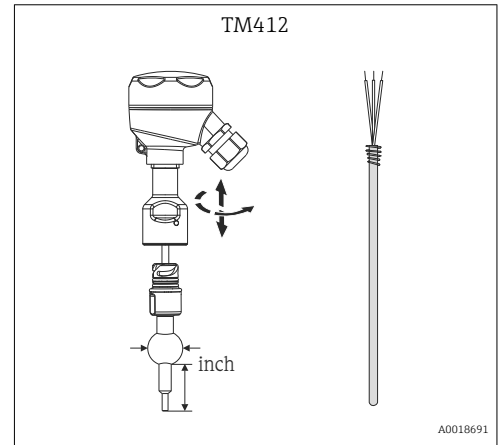
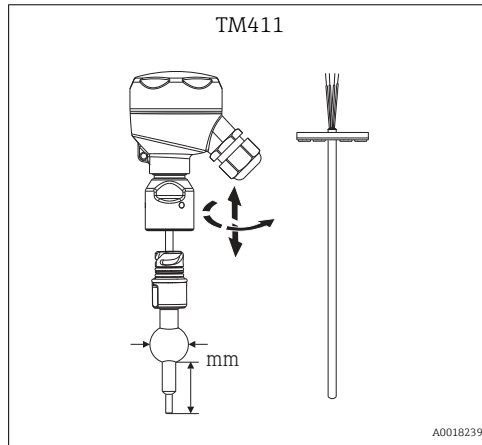

TM40x characterizes the device that uses basic technology, with features such as a fixed, non-replaceable insert, application in non-hazardous areas, standard extension neck, low-cost unit

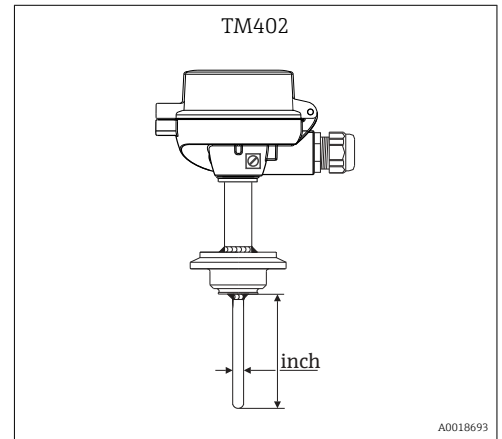
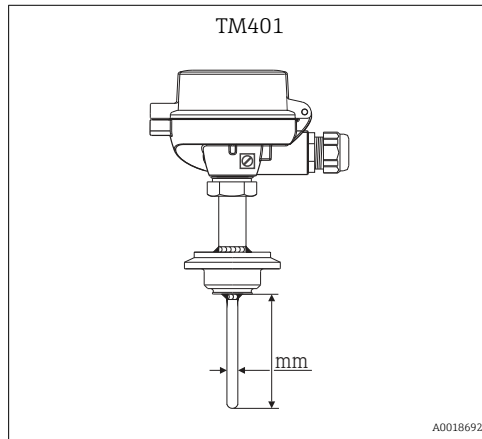

### Measuring principle

#### Resistance thermometer (RTD)

These resistance thermometers use a Pt100 temperature sensor according to IEC 60751. The temperature sensor is a temperature-sensitive platinum resistor with a resistance of 100 Ω at 0 °C (32 °F) and a temperature coefficient  $\alpha = 0.003851 \text{ } ^\circ\text{C}^{-1}$ .

There are generally two different kinds of platinum resistance thermometers:

- **Wire wound (WW):** Here, a double coil of fine, high-purity platinum wire is located in a ceramic support. This is then sealed top and bottom with a ceramic protective layer. Such resistance thermometers not only facilitate very reproducible measurements but also offer good long-term stability of the resistance/temperature characteristic within temperature ranges up to 600 °C (1 112 °F). This type of sensor is relatively large in size and it is comparatively sensitive to vibrations.
- **Thin film platinum resistance thermometers (TF):** A very thin, ultrapure platinum layer, approx. 1 µm thick, is vaporized in a vacuum on a ceramic substrate and then structured photolithographically. The platinum conductor paths formed in this way create the measuring resistance. Additional covering and passivation layers are applied and reliably protect the thin platinum layer from contamination and oxidation, even at high temperatures.

The primary advantages of thin film temperature sensors over wire wound versions are their smaller sizes and better vibration resistance. A relatively low principle-based deviation of the resistance/temperature characteristic from the standard characteristic of IEC 60751 can frequently be observed among TF sensors at high temperatures. As a result, the tight limit values of tolerance category A as per IEC 60751 can only be observed with TF sensors at temperatures up to approx. 300 °C (572 °F).

### Thermocouples (TC)

Thermocouples are comparatively simple, robust temperature sensors which use the Seebeck effect for temperature measurement: if two electrical conductors made of different materials are connected at a point, a weak electrical voltage can be measured between the two open conductor ends if the conductors are subjected to a thermal gradient. This voltage is called thermoelectric voltage or electromotive force (emf.). Its magnitude depends on the type of conducting materials and the temperature difference between the "measuring point" (the junction of the two conductors) and the "cold junction" (the open conductor ends). Accordingly, thermocouples primarily only measure differences in temperature. The absolute temperature at the measuring point can be determined from these if the associated temperature at the cold junction is known or is measured separately and compensated for. The material combinations and associated thermoelectric voltage/temperature characteristics of the most common types of thermocouple are standardized in the IEC 60584 and ASTM E230/ANSI MC96.1 standards.

### Measuring system

Endress+Hauser offers a complete portfolio of optimized components for the temperature measuring point – everything you need for the seamless integration of the measuring point into the overall facility. This includes:

- Power supply unit/barrier
- Display units
- Data managers
- Overvoltage protection

 For more information, see the brochure 'System Products and Data Managers - Solutions for the loop' (FA00016K)

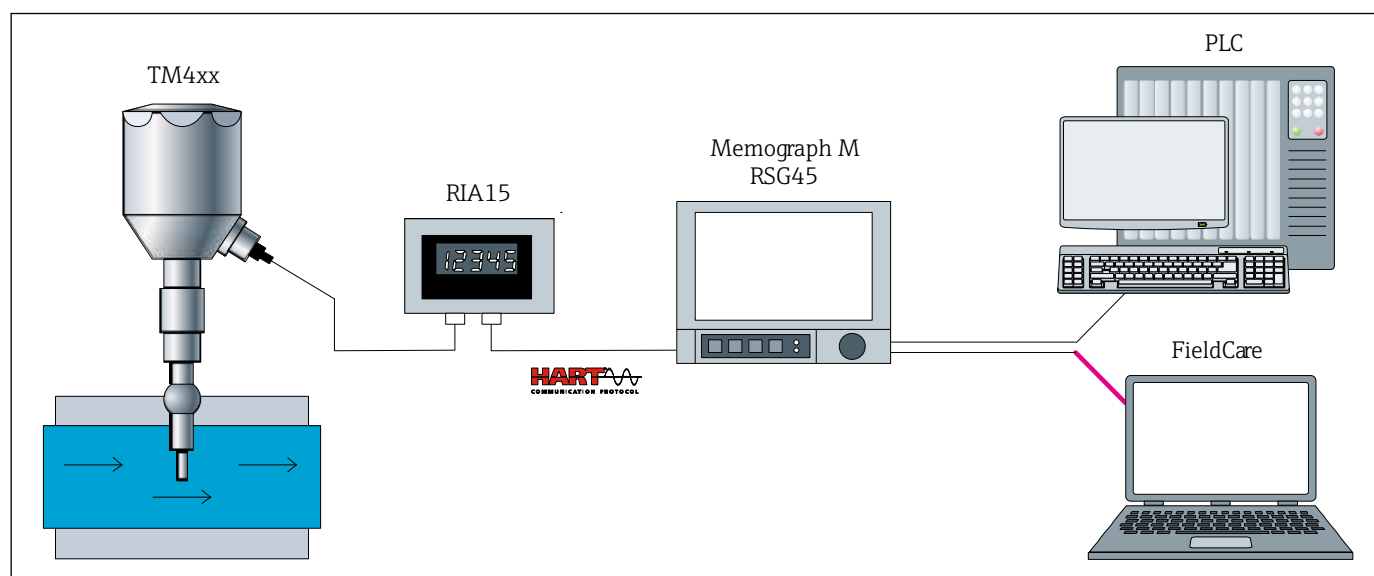

A0033768

 1 Example of application, measuring point layout with additional Endress+Hauser components

- iTHERM TM4x2: Installed RTD thermometer with integrated HART® head transmitter
- Display unit RIA15:
  - Display of 4 to 20 mA measured values or HART® process variables
  - Loop-powered
  - Voltage drop ≤1 V (HART® ≤1.9 V)
- Data Management Memograph M RSG45:
  - Tamper-proof data storage and access (FDA 21 CFR 11)
  - HART® gateway functionality; Up to 40 HART® devices connected at a time
  - Communication capabilities: Modbus, Profibus DP, PROFINET, EtherNet/IP
- PLC / FieldCare: Field Data Manager Software MS20 - Automatic service for report generation, printing reports, read out of data, storing of data, secure export, pdf generation Read out measured data via online interface or from mass storage Online visualization of instantaneous values ("live data") . More information on this can be found in the Technical Information, see "Documentation".

## Input

**Measured variable** Temperature (temperature-linear transmission behavior)

**Measuring range**

Sensor type	Measuring range
Pt100 thin-film	-50 to +200 °C (-58 to +392 °F)

## Output

**Output signal**

Generally, the measured value can be transmitted in one of two ways:

- Directly-wired sensors - sensor measured values forwarded without a transmitter.
- Via all common protocols by selecting an appropriate Endress+Hauser iTEMP temperature transmitter. All the transmitters listed below are mounted directly in the terminal head and wired with the sensory mechanism.

**Family of temperature transmitters**

Thermometers fitted with iTEMP transmitters are an installation-ready complete solution to improve temperature measurement by significantly increasing accuracy and reliability, when compared to direct wired sensors, as well as reducing both wiring and maintenance costs.

### PC programmable head transmitters

They offer a high degree of flexibility, thereby supporting universal application with low inventory storage. The iTEMP transmitters can be configured quickly and easily at a PC. Endress+Hauser offers free configuration software which can be downloaded from the Endress+Hauser Website. More information can be found in the Technical Information.

### HART® head transmitters

The transmitter is a 2-wire device with one or two measuring inputs and one analog output. The device not only transfers converted signals from resistance thermometers and thermocouples, it also transfers resistance and voltage signals using HART® communication. Swift and easy operation, visualization and maintenance using universal device configuration tools like FieldCare, DeviceCare or FieldCommunicator 375/475. Integrated Bluetooth® interface for the wireless display of measured values and configuration via E+H SmartBlue (app), optional. For more information, see the Technical Information.

Advantages of the iTEMP transmitters:

- Dual or single sensor input (optionally for certain transmitters)
- Unsurpassed reliability, accuracy and long-term stability in critical processes
- Mathematical functions
- Monitoring of the thermometer drift, sensor backup functionality, sensor diagnostic functions
- Sensor-transmitter matching for dual sensor input transmitter, based on Callendar/Van Dusen coefficients

## Wiring

- i** According to the 3-A<sup>®</sup> Standard electrical connecting cables must be smooth, corrosion-resistant and easy to clean.
- Grounding or shield connections are possible via special ground terminals on the terminal head. → 16

### Wiring diagrams for RTD

- i** According to the 3-A Sanitary Standard and the EHEDG, electrical connecting cables must be smooth, corrosion-resistant and easy to clean.

Type of sensor connection

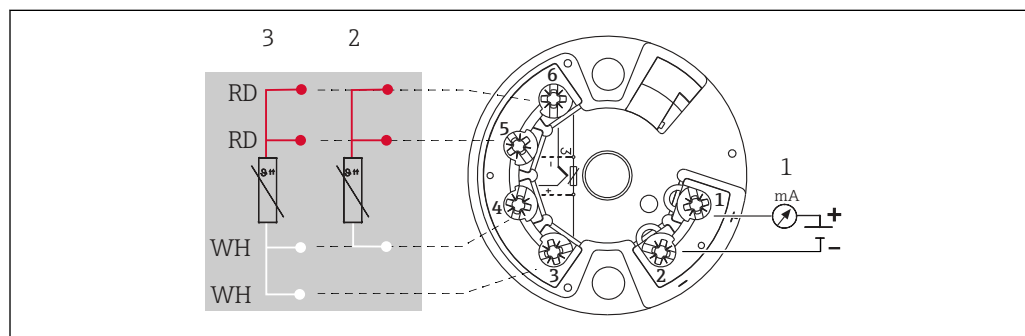

A0045600

- 2** Head mounted transmitter TMT18x (single input). Only available with screw terminals.

- 1 Power supply head transmitter and analog output 4 to 20 mA or bus connection
- 2 3-wire
- 3 4-wire

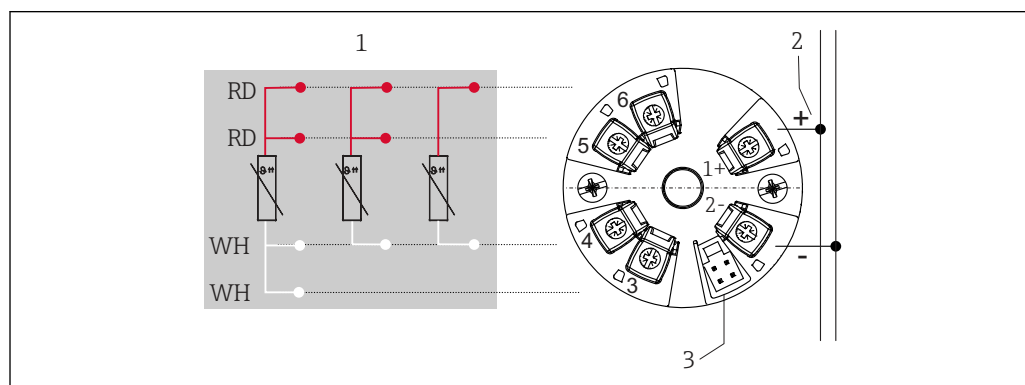

A0047173

- 3** Head mounted transmitter TMT31 (single input)

- 1 RTD sensor input: 4-, 3- and 2-wire
- 2 Power supply
- 3 CDI interface

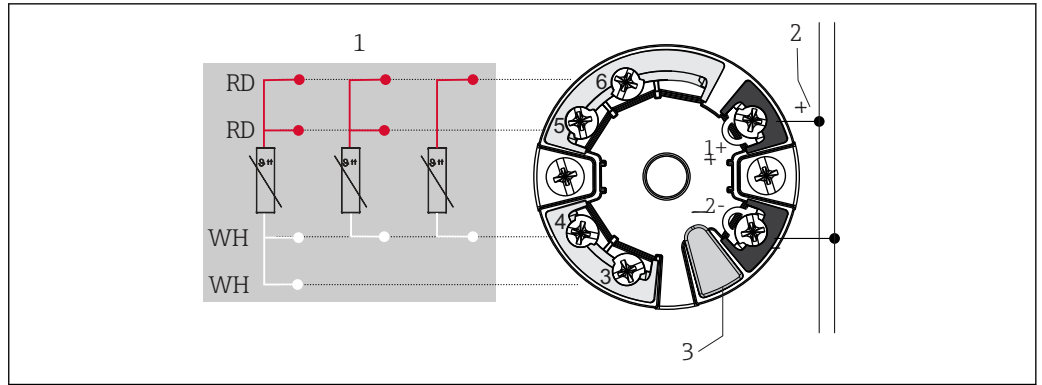

A0045464

4 Head mounted transmitter TMT7x (single input). Fitted with spring terminals if screw terminals are not explicitly selected.

- 1 Sensor Input
- 2 Bus connection and supply voltage
- 3 Display connection

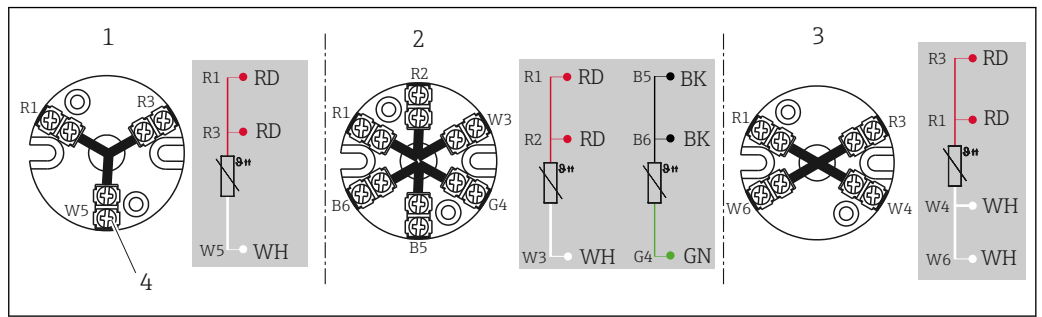

A0045627

5 Terminal block mounted

- 1 3-wire single
- 2 2 x 3-wire single
- 3 4-wire single
- 4 Outside screw

**Cable entries**

See the 'Terminal head' section → 16

**Connector**

PIN assignment of the M12 connectors, connection combinations

Connector	M12 connector 4-pin			
PIN number	1	2	3	4
Electrical connection (terminal head)				
Flying leads	Not connected (not insulated)			
3-wire terminal block (1x Pt100)	RD	RD	WH	
4-wire terminal block (1x Pt100)			WH	WH
1x TMT 4 to 20 mA or HART®	+	i	-	i
PIN position and color code	<ul style="list-style-type: none"> <li>1 BN</li> <li>2 GNYE</li> <li>3 BU</li> <li>4 GY</li> </ul>			

A0018929

Abbreviations

i	RD	WH	BN	GNYE	BU	GY
Insulated <sup>1)</sup>	Red	White	Brown	Green-yellow	Blue	Gray

1) Wires marked 'i' are not connected and are insulated with heat shrink tubes.

Overvoltage protection

To protect against overvoltage in the power supply and signal/communication cables for the thermometer electronics, Endress+Hauser offers the HAW562 surge arrester for DIN rail mounting and the HAW569 for field housing installation.

 For more information see the Technical Information 'HAW562 Surge arrester' TI01012K and 'HAW569 Surge arrester' TI01013K.

## Performance characteristics

Reference conditions

These data are relevant for determining the accuracy of the temperature transmitters used. More information on this can be found in the Technical Information of the iTEMP temperature transmitters.

Maximum measured error

RTD resistance thermometer corresponding to IEC 60751

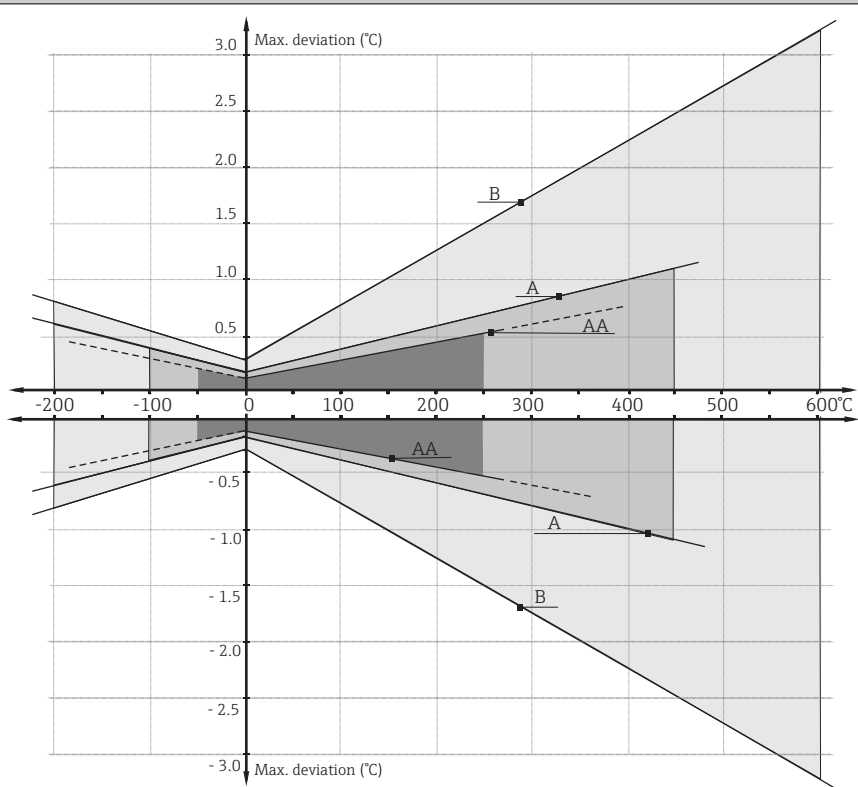
Class	max. Tolerances (°C)	Characteristics
<b>RTD maximum error type TF</b>		
Cl. A	$\pm (0.15 + 0.002 \cdot  t )^{1)}$	
Cl. AA, former 1/3 Cl. B	$\pm (0.1 + 0.0017 \cdot  t )^{1)}$	
Cl. B	$\pm (0.3 + 0.005 \cdot  t )^{1)}$	

1) |t| = absolute value °C

 For measurement errors in °F, calculate using equations in °C, then multiply the outcome by 1.8.



*Temperature ranges for compliance with the tolerance classes*

Sensor type	Operating temperature range	Class B	Class A	Class AA
Pt100 thin film sensor (TF)	-50 to 200 °C (-58 to 392 °F)	-	-30 to 200 °C (-22 to 392 °F)	-

**Influence of ambient temperature**

Depends on the head transmitter used. For details, see Technical Information.

**Self heating**

RTD elements are passive resistances that are measured using an external current. This measurement current causes a self-heating effect in the RTD element itself which in turn creates an additional measurement error. In addition to the measurement current, the size of the measurement error is also affected by the temperature conductivity and flow velocity of the process. This self-heating error is negligible when an Endress+Hauser iTEMP temperature transmitter (very small measurement current) is connected.

**Response time**

Tests in water at 0.4 m/s (1.3 ft/s), according to IEC 60751; 10 K temperature step change.

Pipe diameter	Shape of tip	1x Pt100 thin-film sensor	
		Response time	
		t <sub>50</sub>	t <sub>90</sub>
∅6.35 mm (¼ in)	Straight	5 s	11 s
	Reduced 4.76 mm (3/16 in) x 19.05 mm (0.75 in)	3.5 s	9 s
∅9.53 mm (3/8 in)	Reduced 4.76 mm (3/16 in) x 19.05 mm (0.75 in)	5 s	10.5 s



Response time without transmitter.

---

**Calibration****Calibration of thermometers**

Calibration involves comparing the measured values of a device under test (DUT) with those of a more precise calibration standard using a defined and reproducible measurement method. The aim is to determine the deviation of the DUT's measured values from the true value of the measured variable. Two different methods are used for thermometers:

- Calibration at fixed-point temperatures, e.g. at the freezing point of water at 0 °C,
- Calibration compared against a precise reference thermometer.

The thermometer to be calibrated must display the fixed point temperature or the temperature of the reference thermometer as accurately as possible. Temperature-controlled calibration baths with very homogeneous thermal values, or special calibration furnaces into which the DUT and the reference thermometer, where necessary, can project to a sufficient degree, are typically used for thermometer calibrations.

The measurement uncertainty can increase due to heat dissipation errors and short immersion lengths. The existing measurement uncertainty is listed on the individual calibration certificate.

For accredited calibrations according to ISO17025, the measurement uncertainty shouldn't be twice as high as the accredited measurement uncertainty. If this is exceeded, only a factory calibration can be performed.

**Evaluation of thermometers**

If a calibration with an acceptable uncertainty of measurement and transferable measurement results is not possible, Endress+Hauser offers customers a thermometer evaluation measurement service, if technically feasible. This is the case when:

- The process connections/flanges are too big or the immersion length (IL) is too short to allow the DUT to be immersed sufficiently in the calibration bath or furnace (see the following table), or
- Due to heat conduction along the thermometer tube, the resulting sensor temperature generally deviates significantly from the actual bath/furnace temperature.

The measured value of the DUT is determined using the maximum possible immersion depth and the specific measuring conditions and measurement results are documented on an evaluation certificate.

For the device, Endress+Hauser offers standard calibrations at a reference temperature of -20 to +200 °C (-4 to +392 °F) based on the ITS90 (International Temperature Scale). Calibrations in other temperature ranges are available from your Endress+Hauser sales center on request. Calibrations are traceable to national and international standards. The calibration certificate is referenced to the serial number of the thermometer.

---

**Insulation resistance**

Insulation resistance  $\geq 100 \text{ M}\Omega$  at ambient temperature, measured between the terminals and the outer jacket with a minimum voltage of  $100 \text{ V}_{\text{DC}}$ .

---

## Installation

---

**Orientation**

No restrictions. However, self-draining in the process must be guaranteed. If there is an opening to detect leaks at the process connection, this opening must be at the lowest possible point.

---

**Installation instructions**

The immersion length of the thermometer can influence the accuracy. If the immersion length is too small then errors in the measurement are caused by heat conduction via the process connection and the container wall. If installing into a pipe then the immersion length should ideally be half of the pipe diameter.

Installation possibilities: Pipes, tanks or other plant components

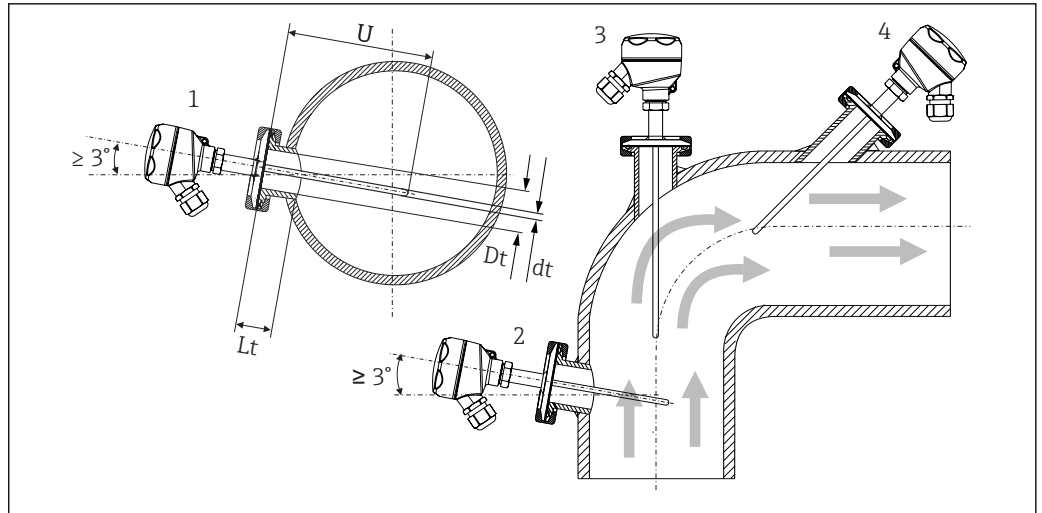

A0008946

**6** Installation examples

- 1, 2 Perpendicular to flow direction, installed at a minimum angle of 3° to ensure self-draining
- 3 On elbows
- 4 Inclined installation in pipes with a small nominal diameter
- U Immersion length

**i** The requirements of the EHEDG and the 3-A Sanitary Standard must be adhered to.

Installation instructions EHEDG/cleanability:  $L_t \leq (D_t - d_t)$

Installation instructions 3-A/cleanability:  $L_t \leq 2(D_t - d_t)$

**i** In the case of pipes with a small nominal diameter, it is advisable for the tip of the thermometer to project well into the process so that it extends past the pipe axis. Installation at an angle (4) could be another solution. When determining the immersion length or installation depth all the parameters of the thermometer and of the medium to be measured must be taken into account (e.g. flow velocity, process pressure).

Pay attention to the exact position of the sensor element in the thermometer tip.

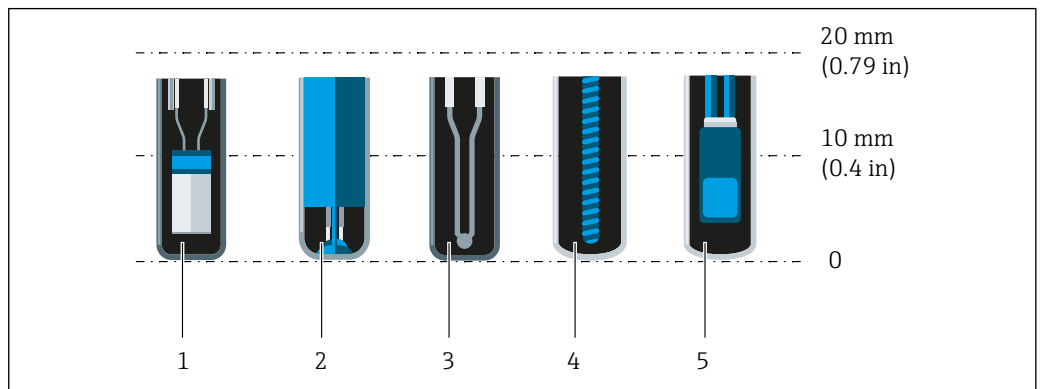

A0041814

- 1 StrongSens or TrustSens at 5 to 7 mm (0.2 to 0.28 in)
- 2 QuickSens at 0.5 to 1.5 mm (0.02 to 0.06 in)
- 3 Thermocouple (not grounded) at 3 to 5 mm (0.12 to 0.2 in)
- 4 Wire wound sensor at 5 to 20 mm (0.2 to 0.79 in)
- 5 Standard thin-film sensor at 5 to 10 mm (0.2 to 0.39 in)

To keep the influence of heat dissipation to a minimum and to achieve the best possible measurement results, 20 to 25 mm (0.79 to 0.98 in) should be in contact with the medium in addition to the actual sensor element.

This results in the following recommended minimum immersion lengths

- TrustSens or StrongSens 30 mm (1.18 in)
- QuickSens 25 mm (0.98 in)
- Wire wound sensor 45 mm (1.77 in)
- Standard thin-film sensor 35 mm (1.38 in)

It is particularly important to take this into consideration for T-pieces, as the immersion length is very short on account of their design, and the measured error is higher as a result. It is therefore recommended to use elbow pieces with QuickSens sensors.

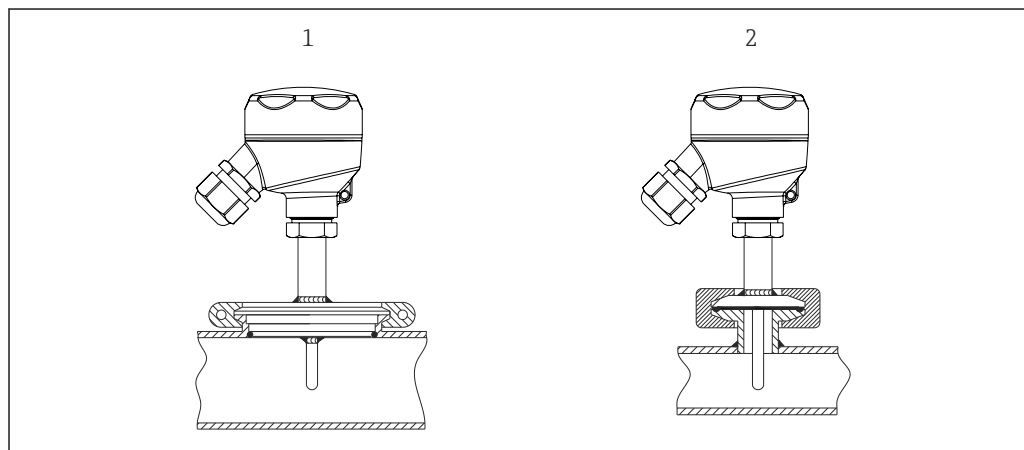

A0018881

■ 7 Process connections for thermometer installation in pipes with small nominal diameters

- 1 Varivent® - process connection  $D = 50$  mm for DN25 pipes
- 2 Clamp or micro-clamp

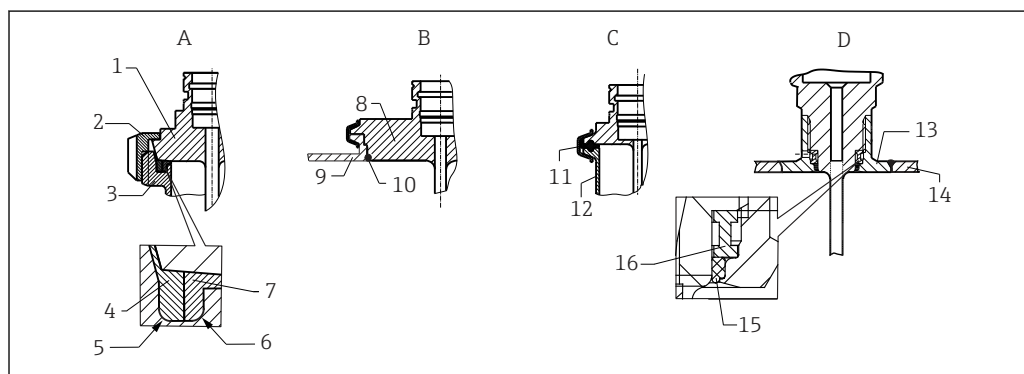

A0040345

■ 8 Detailed installation instructions for hygiene-compliant installation

- A Milk pipe connection according to DIN 11851, only in connection with EHEDG certified and self-centering sealing ring
  - 1 Sensor with milk pipe connection
  - 2 Groove slip-on nut
  - 3 Counterpart connection
  - 4 Centering ring
  - 5 R0.4
  - 6 R0.4
  - 7 Sealing ring
- B Varivent® process connection for VARINLINE® housing
  - 8 Sensor with Varivent connection
  - 9 Counterpart connection
  - 10 O-ring
- C Clamp according to ISO 2852
  - 11 Molded seal
  - 12 Counterpart connection
- D Process connection Liquiphant-M G1', horizontal installation
  - 13 Weld-in adapter
  - 14 Vessel wall
  - 15 O-ring
  - 16 Thrust collar

**NOTICE**

The following actions must be taken if a sealing ring (O-ring) or seal fails:

- ▶ The thermometer must be removed.
- ▶ The thread and the O-ring joint/sealing surface must be cleaned.
- ▶ The sealing ring or seal must be replaced.
- ▶ CIP must be performed after installation.

In the case of weld-in connections, exercise the necessary degree of care when performing the welding work on the process side:

1. Use suitable welding material.
2. Flush-weld or weld with welding radius  $\geq 3.2$  mm (0.13 in).
3. Avoid crevices, folds or gaps.
4. Ensure the surface is honed and polished,  $Ra \leq 0.76$   $\mu\text{m}$  (30  $\mu\text{in}$ ).

Pay attention to the following when installing the thermometer to ensure that the cleanability is not affected:

1. The installed sensor is suitable for CIP (cleaning in place). Cleaning is performed together with the pipe or tank. In the case of internal tank fixtures using process connection nozzles, it is important to ensure that the cleaning assembly directly sprays this area so that it is cleaned properly.
2. The Varivent® couplings enable flush-mount installation.

## Environment

<b>Ambient temperature range</b>	<b>Terminal head</b>	<b>Temperature in °C (°F)</b>
	Without mounted head transmitter	Depends on the terminal head used and the cable gland or fieldbus connector, see 'Terminal heads' section → 16
	With mounted head transmitter	-40 to 85 °C (-40 to 185 °F)
<b>Storage temperature</b>	For information, see the ambient temperature.	
<b>Humidity</b>	Depends on the transmitter used. If Endress+Hauser iTEMP head transmitters are used: <ul style="list-style-type: none"> <li>▪ Condensation permitted as per IEC 60 068-2-33</li> <li>▪ Maximum relative humidity: 95% as per IEC 60068-2-30</li> </ul>	
<b>Climate class</b>	As per EN 60654-1, Class C	
<b>Degree of protection</b>	Max. IP69K, depending on the design (terminal head, connector, etc.)	
<b>Shock and vibration resistance</b>	The Endress+Hauser inserts meet the requirements of IEC 60751 which specify shock and vibration resistance of 3g in the range from 10 to 500 Hz. The vibration resistance at the measuring point depends on the sensor type and design, see the following table:	
	<b>Version</b>	<b>Vibration resistance for the sensor tip</b>
	Pt100 (TF)	30 m/s <sup>2</sup> (3g)
<b>Electromagnetic compatibility (EMC)</b>	Depends on the head transmitter used. For details see the Technical Information.	

## Process

<b>Process temperature range</b>	Maximum -50 to +200 °C (-58 to +392 °F)
----------------------------------	---

**Thermal shock**

Thermal shock resistance in CIP/SIP process with a temperature increase from +5 to +130 °C (+41 to +266 °F) within 2 seconds.

**Process pressure range**

The maximum possible process pressure depends on various influencing factors, such as the design, process connection and process temperature. For information on the maximum possible process pressures for the individual process connections, see the 'Process connection' section. → 18

**i** It is possible to check the mechanical loading capacity as a function of the installation and process conditions online in the Thermowell (TW) Sizing Module for thermowells in the Endress+Hauser Applicator software. See 'Accessories' section.

**Example of the permitted flow velocity depending on the immersion length and process medium**

The highest flow velocity tolerated by the thermometer diminishes with increasing insert immersion length exposed to the stream of the fluid. In addition it is dependent on the diameter of the thermometer tip, on the kind of measuring medium, on the process temperature and on the process pressure. The following figures exemplify the maximum permitted flow velocities in water and superheated steam at a process pressure of 40 bar (580 PSI).

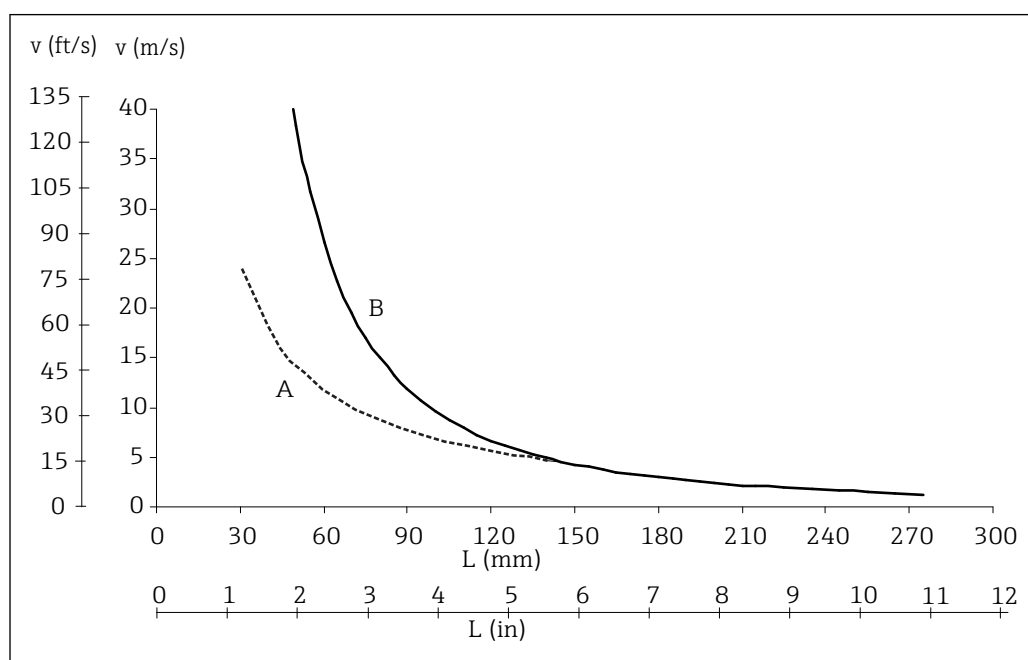

**9** Permitted flow velocities, thermowell diameter 6.35 mm (1/4 in)

A Medium water at  $T = 50\text{ °C}$  (122 °F)

B Medium superheated steam at  $T = 400\text{ °C}$  (752 °F)

L Immersion length exposed to flow

v Flow velocity

**Medium - state of aggregation**

Gaseous or liquid (also with high viscosity, e.g. yogurt).

## Mechanical construction

### Design, dimensions

All dimensions in mm (in).

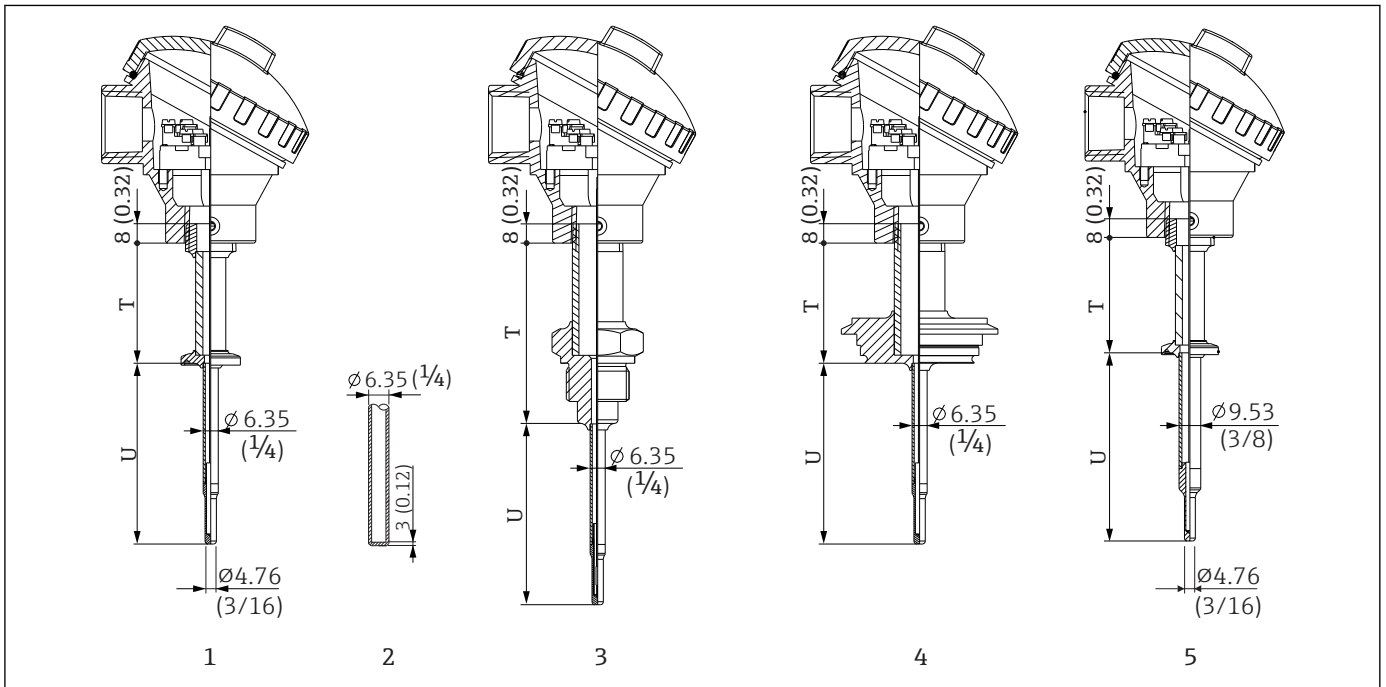

A0034462

- 1 Thermometer with clamp process connection and  $\varnothing 6.35$  mm ( $\frac{1}{4}$  in) thermowell with reduced tip  $4.76$  mm ( $\frac{3}{16}$  in)
  - 2 Optional for all thermometers with  $\varnothing 6.35$  mm ( $\frac{1}{4}$  in) thermowell: straight tip shape
  - 3 Thermometer with ISO228 process connection and  $\varnothing 6.35$  mm ( $\frac{1}{4}$  in) thermowell with reduced tip  $4.76$  mm ( $\frac{3}{16}$  in)
  - 4 Thermometer with Varivent process connection and  $\varnothing 6.35$  mm ( $\frac{1}{4}$  in) thermowell with reduced  $4.76$  mm ( $\frac{3}{16}$  in)
  - 5 Thermometer with clamp process connection and  $\varnothing 9.53$  mm ( $\frac{3}{8}$  in) thermowell with reduced tip  $4.76$  mm ( $\frac{3}{16}$  in)
- T Length of extension neck  
U Immersion length

### Weight

Depending on the configuration

### Material

The temperatures for continuous operation specified in the following table are only intended as reference values for use of the various materials in air and without any significant compressive load.

The maximum operating temperatures can be reduced considerably in cases where abnormal conditions such as high mechanical load occur or in aggressive media.

Designation	Recommended max. temperature for continuous use in air	Properties
AISI 316L	650 °C (1 202 °F) <sup>1)</sup>	<ul style="list-style-type: none"> <li>■ Austenitic, stainless steel</li> <li>■ High corrosion resistance in general</li> <li>■ Particularly high corrosion resistance in chlorine-based and acidic, non-oxidizing atmospheres through the addition of molybdenum (e.g. phosphoric and sulfuric acids, acetic and tartaric acids with a low concentration)</li> <li>■ Increased resistance to intergranular corrosion and pitting</li> <li>■ The wetted part from a 316L thermowell withstand a passivation process with a 3% sulphuric acid</li> <li>■ Available with 3-A marked sensors</li> </ul>

- 1) Can be used to a limited extent up to 800 °C (1472 °F) for low compressive loads and in non-corrosive media. Contact your Endress+Hauser sales team for further information.

### Surface roughness

Values for wetted surfaces:

Standard surface, mechanically polished <sup>1)</sup>	$R_a \leq 0.76 \mu\text{m}$ (30 $\mu\text{in}$ )
Mechanically polished, buffed <sup>2)</sup>	$R_a \leq 0.38 \mu\text{m}$ (15 $\mu\text{in}$ )

- 1) Or equivalent treatment that guarantees  $R_a$  max  
 2) Not compliant with ASME BPE

### Terminal heads

All terminal heads have an internal shape and size in accordance with DIN EN 50446, flat face and a thermometer connection with a ½" NPT thread. All dimensions in mm (in). The sample cable glands in the diagrams correspond to M20x1.5 connections with non-Ex polyamide cable glands. Specifications without head transmitter installed. For ambient temperatures with head transmitter installed, see the 'Environment' section. →  13

As a special feature, Endress+Hauser offers terminal heads with optimized terminal accessibility for easy installation and maintenance.

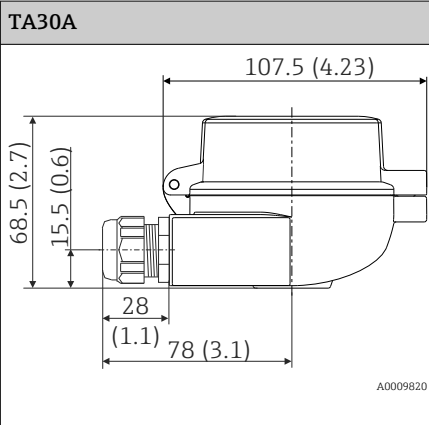
TA30A	Specification
	<ul style="list-style-type: none"> <li>■ Protection class:           <ul style="list-style-type: none"> <li>■ IP66/68 (NEMA Type 4x incl.)</li> <li>■ For ATEX: IP66/67</li> </ul> </li> <li>■ Temperature: -50 to +150 °C (-58 to +302 °F) without cable gland</li> <li>■ Material: aluminum, polyester powder coated</li> <li>■ Seals: silicone</li> <li>■ Threaded cable entry: G ½", ½" NPT and M20x1.5;</li> <li>■ Protection armature connection: ½" NPT, M24x1.5</li> <li>■ Head color: blue, RAL 5012</li> <li>■ Cap color: gray, RAL 7035</li> <li>■ Weight: 330 g (11.64 oz)</li> <li>■ Ground terminal, internal and external</li> <li>■ Available with 3-A marked sensors</li> </ul>

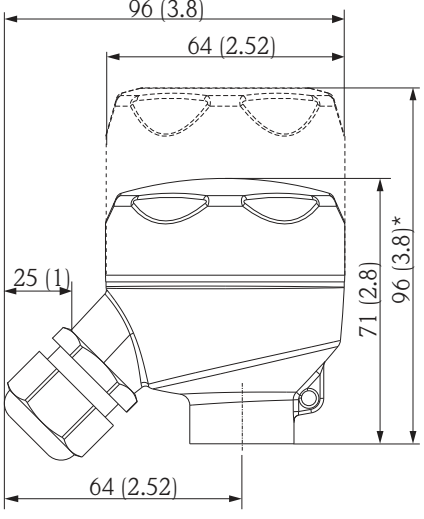

TA30R (optionally with display window in cover)	Specification
 <p data-bbox="507 875 922 925">* Dimensions of version with display window in cover</p>	<ul style="list-style-type: none"> <li>■ Degree of protection - standard version: IP69K (NEMA Type 4x encl.)</li> <li>■ Degree of protection - version with display window: IP66/68 (NEMA Type 4x encl.)</li> <li>■ Temperature: -50 to +130 °C (-58 to +266 °F) without cable gland</li> <li>■ Material: stainless steel 316L, abrasive-blasted or polished</li> <li>■ Seals: EPDM</li> <li>■ Display window: polycarbonate (PC)</li> <li>■ Cable entry thread ½" NPT and M20x1.5</li> <li>■ Weight                             <ul style="list-style-type: none"> <li>■ Standard version: 360 g (12.7 oz)</li> <li>■ Version with display window: 460 g (16.23 oz)</li> </ul> </li> <li>■ Display window in cover optionally for head transmitter with display TID10</li> <li>■ Protection armature connection: M24x1.5 or ½" NPT</li> <li>■ Ground terminal: internal in standard version; external terminal optionally available</li> <li>■ Available with 3-A marked sensors</li> <li>■ Not allowed for Class II and III applications</li> </ul>

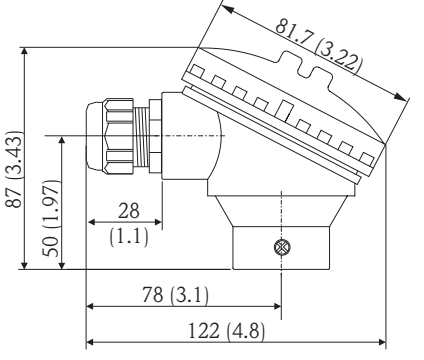
TA30S	Specification
	<ul style="list-style-type: none"> <li>■ Degree of protection: IP65 (NEMA Type 4x encl.)</li> <li>■ Temperature: -40 to +85 °C (-40 to +185 °F) without cable gland</li> <li>■ Material: polypropylene (PP), FDA-compliant, seals: O-ring EPDM</li> <li>■ Cable entry thread: ¾" NPT (with adapter for ½" NPT), M20x1.5</li> <li>■ Protective assembly connection: ½" NPT</li> <li>■ Color: white</li> <li>■ Weight: approx. 100 g (3.5 oz)</li> <li>■ Ground terminal: only internal via auxiliary terminal</li> <li>■ Not allowed for Class II and III applications</li> <li>■ Available with 3-A marked sensors</li> </ul>

*Cable glands and fieldbus connectors*

Type	Suitable for cable entry	Degree of protection	Temperature range
Cable gland, polyamide	½" NPT, ¾" NPT, M20x1.5	IP68	-40 to +100 °C (-40 to +212 °F)
	½" NPT, M20x1.5	IP69K	-20 to +95 °C (-4 to +203 °F)
Fieldbus connector (M12, 4-pin)	½" NPT, M20x1.5	IP67, NEMA Type 6	-40 to +105 °C (-40 to +221 °F)

## Process connections

All dimensions in mm (in).

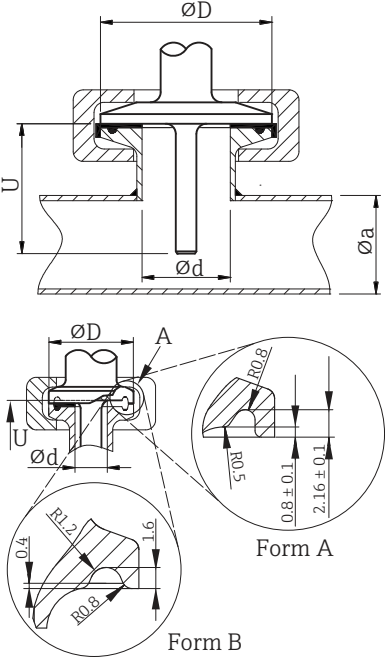
Type	Version	Dimensions		Technical properties	Conformity
	$\varnothing d$ : <sup>1)</sup>	$\varnothing D$	$\varnothing a$		
Clamp according to ISO 2852 	Tri-clamp ¾" (DN18) Form A	25 mm (0.98 in)	-	<ul style="list-style-type: none"> <li>▪ <math>P_{max.} = 16</math> bar (232 psi), depends on clamp ring and suitable seal</li> <li>▪ 3-A marked</li> </ul>	ASME BPE type A
	Clamp ISO 2852 ½" (DN12 - 21.3) Form B	34 mm (1.34 in)	16 to 25.3 mm (0.63 to 0.99 in)		ISO 2852
	Tri-clamp 1" - 1½" (DN25 - 38) Form B	50.5 mm (1.99 in)	29 to 42.4 mm (1.14 to 1.67 in)	<ul style="list-style-type: none"> <li>▪ <math>P_{max.} = 16</math> bar (232 psi), depends on clamp ring and suitable seal</li> <li>▪ 3-A marked and EHEDG certified (combined with Combifit seal)</li> </ul>	ASME BPE type B
	Tri-clamp 2" (DN40 - 51) Form B	64 mm (2.52 in)	44.8 to 55.8 mm (1.76 to 2.2 in)		
Form A: In compliance with ASME BPE Type A Form B: In compliance with ASME BPE Type B and ISO 2852 <small>A0009566</small>					

1) Pipes in accordance with ISO 2037 and BS 4825 Part 1

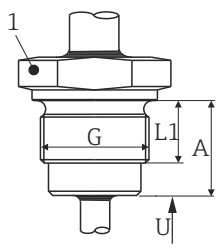
Type	Version G	Dimensions			Technical properties
		L1 thread length	A	1 (SW/AF)	
Thread according to ISO 228 (for Liquiphant weld-in adapter) 	G¾" for FTL20 adapter	16 mm (0.63 in)	25.5 mm (1 in)	32	<ul style="list-style-type: none"> <li>▪ <math>P_{max.} = 25</math> bar (362 psi) at max. 150 °C (302 °F)</li> <li>▪ <math>P_{max.} = 40</math> bar (580 psi) at max. 100 °C (212 °F)</li> <li>▪ In connection with FTL31/33/50 adapter, see TI00426F for details about 3-A conformity and EHEDG tested O-ring</li> <li>▪ Minimum extension neck lengths: <math>\geq 76.2</math> mm (3 in)</li> </ul>
	G¾" for FTL50 adapter				
	G1" for FTL50 adapter	18.6 mm (0.73 in)	29.5 mm (1.16 in)	41	
					<small>A0009572</small>

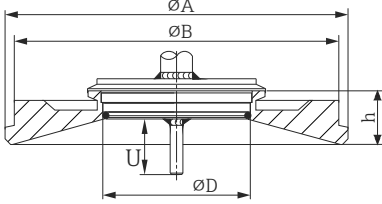
Type	Version	Dimensions				Technical properties	
		ØD	ØA	ØB	h	P <sub>max.</sub>	
Varivent® 	Type F	50 mm (1.97 in)	145 mm (5.71 in)	135 mm (5.31 in)	24 mm (0.95 in)	10 bar (145 psi)	<ul style="list-style-type: none"> <li>3-A marked and EHEDG certified</li> <li>ASME BPE compliance</li> </ul>
	Type N	68 mm (2.67 in)	165 mm (6.5 in)	155 mm (6.1 in)	24.5 mm (0.96 in)		

**i** The VARINLINE® housing connection flange is suitable for weld-in into the conical or torispherical head in tanks or containers with a small diameter (≤ 1.6 m (5.25 ft)) and up to a wall thickness of 8 mm (0.31 in).

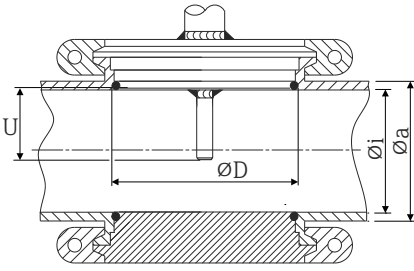
Type	Technical properties
Varivent® for VARINLINE® housing for installation in pipes 	<ul style="list-style-type: none"> <li>3-A marked and EHEDG certified</li> <li>ASME BPE compliance</li> </ul>

Version	Dimensions			P <sub>max.</sub>
	ØD	Øi	Øa	
Type N, according to DIN 11866, series C	68 mm (2.67 in)	OD 1½": 34.9 mm (1.37 in)	OD 1½": 38.1 mm (1.5 in)	OD 1½" to OD 2½": 16 bar (232 psi)
		OD 2": 47.2 mm (1.86 in)	OD 2": 50.8 mm (2 in)	
		OD 2½": 60.2 mm (2.37 in)	OD 2½": 63.5 mm (2.5 in)	
Type N, according to DIN 11866, series C	68 mm (2.67 in)	OD 3": 73 mm (2.87 in)	OD 3": 76.2 mm (3 in)	OD 3" to OD 4": 10 bar (145 psi)
		OD 4": 97.6 mm (3.84 in)	OD 4": 101.6 mm (4 in)	
Type F, according to DIN 11866, series C	50 mm (1.97 in)	OD 1": 22.2 mm (0.87 in)	OD 1": 25.4 mm (1 in)	16 bar (232 psi)

**Tip shape**

The thermal response time, the reduction of the flow cross-section and the mechanical load that occurs in the process are the criteria that matter when selecting the shape of the tip. Advantages of using reduced thermometer tips:

- A smaller tip shape has less impact on the flow characteristics of the pipe carrying the medium.
- The flow characteristics are optimized, thereby increasing the stability of the thermowell.
- Endress+Hauser offers users a range of thermowell tips to meet every requirement:
  - Straight tip
  - Reduced tip with Ø4.76 mm (3/16 in): walls of lower thickness significantly reduce the response times of the overall measuring point
  - Reduced tip for Tee and Elbow thermowell with Ø4.5 mm (0.18 in)

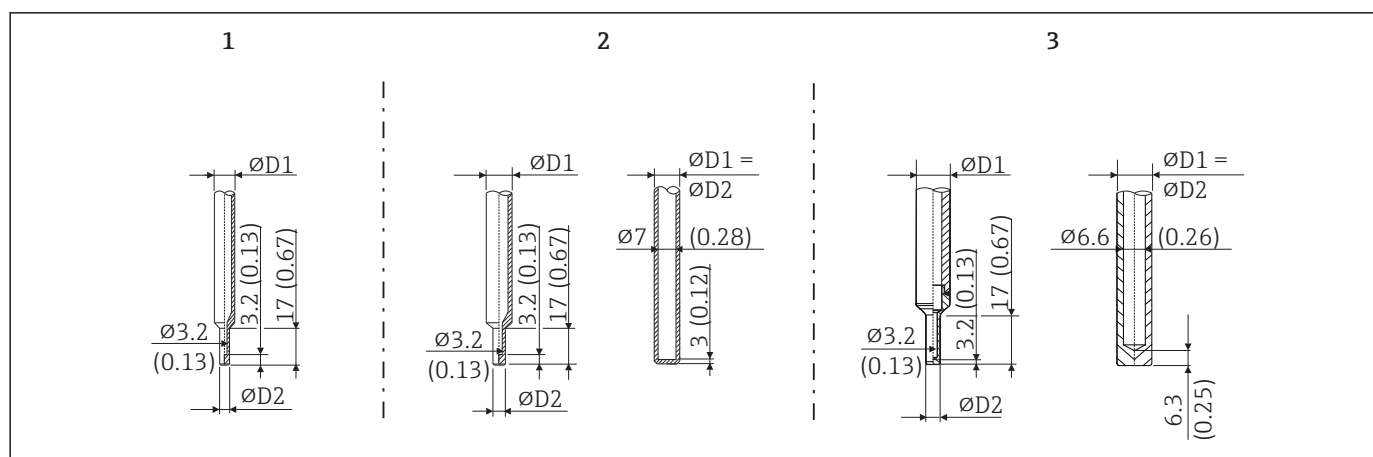

A0033991

10 Thermowell tips available (reduced or straight)

Item No.	Thermowell (ØD1)	Tip (ØD2)	Insert (ØID)
1	Ø6.35 mm (¼ in)	Reduced tip with Ø4.76 mm (¾ <sub>16</sub> in)	Ø3 mm (0.12 in)
2	Ø9.53 mm (¾ in)	<ul style="list-style-type: none"> <li>■ Reduced tip with Ø4.76 mm (¾<sub>16</sub> in)</li> <li>■ Straight tip</li> </ul>	<ul style="list-style-type: none"> <li>■ Ø3 mm (0.12 in)</li> <li>■ Ø6.35 mm (¼ in) or 6 mm (0.24 in)</li> </ul>
3	Ø12.7 mm (½ in)	<ul style="list-style-type: none"> <li>■ Reduced tip with Ø4.76 mm (¾<sub>16</sub> in)</li> <li>■ Straight tip</li> </ul>	<ul style="list-style-type: none"> <li>■ Ø3 mm (0.12 in)</li> <li>■ Ø6.35 mm (¼ in) or 6 mm (0.24 in)</li> </ul>

**i** It is possible to check the mechanical loading capacity as a function of the installation and process conditions online in the TW Sizing Module for thermowells in the Endress+Hauser Applicator software. See 'Accessories' section. → 22

## Certificates and approvals

Current certificates and approvals that are available for the product can be selected via the Product Configurator at [www.endress.com](http://www.endress.com):

1. Select the product using the filters and search field.
2. Open the product page.
3. Select **Configuration**.

### Hygiene standard

- EHEDG certification, type EL CLASS I. EHEDG certified/tested process connections. → 18
- 3-A Authorization No. 1144, 3-A Sanitary Standard 74-06. Listed process connections. → 18
- ASME BPE, Declaration of Conformity, can be ordered for options indicated
- FDA-compliant
- All surfaces in contact with the medium are free from materials derived from bovine animals or other livestock (ADI/TSE)

### Materials in contact with food/product (FCM)

The materials of the thermometer in contact with food/product (FCM) comply with the following European regulations:

- (EC) No. 1935/2004, Article 3, paragraph 1, Articles 5 and 17 on materials and articles intended to come into contact with food.
- (EC) No. 2023/2006 on good manufacturing practice for materials and articles intended to come into contact with food.
- (EU) No. 10/2011 on plastic materials and articles intended to come into contact with food.

**Other standards and guidelines**

- IEC 60529: Degrees of protection provided by enclosures (IP code)
- IEC 61010-1: Safety requirements for electrical equipment for measurement, control and laboratory use
- IEC 60751: Industrial platinum resistance thermometers
- ASTM E 1137/E1137M-2008: Standard Specification for Industrial Platinum Resistance Thermometers
- EN 50281-1-1: Electrical apparatus protected by enclosures
- DIN EN 50446: Terminal heads
- IEC 61326-1: Electromagnetic compatibility (electrical equipment for measurement, control and laboratory use - EMC requirements)
- PMO: Pasteurized Milk Ordinance 2001 Revision, U.S. Food and Drug Administration, Center for Food Safety & Applied Nutrition

**Material resistance**

Material resistance - including resistance of housing - to the following Ecolab cleaning/disinfection agents:

- P3-topax 66
- P3-topactive 200
- P3-topactive 500
- P3-topactive OKTO
- And demineralized water

**Surface purity**

Free from oil and grease, optional

## Ordering information

Detailed ordering information is available from your nearest sales organization [www.addresses.endress.com](http://www.addresses.endress.com) or in the Product Configurator at [www.endress.com](http://www.endress.com):

1. Select the product using the filters and search field.
2. Open the product page.
3. Select **Configuration**.

**Product Configurator - the tool for individual product configuration**

- Up-to-the-minute configuration data
- Depending on the device: Direct input of measuring point-specific information such as measuring range or operating language
- Automatic verification of exclusion criteria
- Automatic creation of the order code and its breakdown in PDF or Excel output format
- Ability to order directly in the Endress+Hauser Online Shop

## Accessories

Various accessories, which can be ordered with the device or subsequently from Endress+Hauser, are available for the device. Detailed information on the order code in question is available from your local Endress+Hauser sales center or on the product page of the Endress+Hauser website: [www.endress.com](http://www.endress.com).

### Device-specific accessories

#### Weld-in adapter



For more information about order codes and hygienic compliance of the adapters and spare parts, see Technical Information (TI00426F).

Weld-in adapter						
	G 3/4", d=29 for pipe-mounting	G 3/4", d=50 for vessel-mounting	G 3/4", d=55 with flange	G 1", d=53 without flange	G 1", d=60 with flange	G 1" adjustable
Material	316L (1.4435)	316L (1.4435)	316L (1.4435)	316L (1.4435)	316L (1.4435)	316L (1.4435)
Roughness $\mu\text{m}$ ( $\mu\text{in}$ ) process side	$\leq 1.5$ (59.1)	$\leq 0.8$ (31.5)	$\leq 0.8$ (31.5)	$\leq 0.8$ (31.5)	$\leq 0.8$ (31.5)	$\leq 0.8$ (31.5)





Maximum process pressure for the weld-in adapters:

- 25 bar (362 PSI) at maximum 150 °C (302 °F)
- 40 bar (580 PSI) at maximum 100 °C (212 °F)



### Communication-specific accessories

Configuration kit TXU10	Configuration kit for PC-programmable transmitter with setup software and interface cable for PC with USB port Order code: TXU10-xx
Commubox FXA195 HART	For intrinsically safe HART communication with FieldCare via the USB interface. For details, see Technical Information TI00404F
Wireless HART adapter SWA70	Is used for the wireless connection of field devices. The WirelessHART adapter can be easily integrated into field devices and existing infrastructures, offers data protection and transmission safety and can be operated in parallel with other wireless networks with minimum cabling complexity. For details, see Operating Instructions BA00061S

Service-specific accessories

Accessories	Description
Applicator	<p>Software for selecting and sizing Endress+Hauser measuring devices:</p> <ul style="list-style-type: none"> <li>▪ Calculation of all the necessary data for identifying the optimum measuring device: e.g. pressure loss, accuracy or process connections.</li> <li>▪ Graphic illustration of the calculation results</li> </ul> <p>Administration, documentation and access to all project-related data and parameters over the entire life cycle of a project.</p> <p>Applicator is available:</p> <ul style="list-style-type: none"> <li>▪ Via the Internet: <a href="https://portal.endress.com/webapp/applicator">https://portal.endress.com/webapp/applicator</a></li> <li>▪ On CD-ROM for local PC installation.</li> </ul>
Configurator	<p>Product Configurator - the tool for individual product configuration</p> <ul style="list-style-type: none"> <li>▪ Up-to-the-minute configuration data</li> <li>▪ Depending on the device: Direct input of measuring point-specific information such as measuring range or operating language</li> <li>▪ Automatic verification of exclusion criteria</li> <li>▪ Automatic creation of the order code and its breakdown in PDF or Excel output format</li> <li>▪ Ability to order directly in the Endress+Hauser Online Shop</li> </ul> <p>The Configurator is available on the Endress+Hauser website: <a href="http://www.endress.com">www.endress.com</a> -&gt; Click "Corporate" -&gt; Select country -&gt; Click "Products" -&gt; Select the product using the filters and search field -&gt; Open product page -&gt; The "Configure" button to the right of the product image opens the Product Configurator.</p>
W@M	<p>Life cycle management for your plant</p> <p>W@M supports with a wide range of software applications over the entire process: from planning and procurement, to the installation, commissioning and operation of the measuring devices. All the relevant device information, such as the device status, spare parts and device-specific documentation, is available for every device over the entire life cycle.</p> <p>The application already contains the data of your Endress+Hauser device. Endress+Hauser also takes care of maintaining and updating the data records.</p> <p>W@M is available:</p> <ul style="list-style-type: none"> <li>▪ Via the Internet: <a href="http://www.endress.com/lifecyclemanagement">www.endress.com/lifecyclemanagement</a></li> <li>▪ On CD-ROM for local PC installation.</li> </ul>
FieldCare SFE500	<p>FDT-based plant asset management tool from Endress+Hauser.</p> <p>It can configure all smart field units in your system and helps you manage them. By using the status information, it is also a simple but effective way of checking their status and condition.</p> <p> For details, see Operating Instructions BA00027S and BA00065S</p>
DeviceCare SFE100	<p>Configuration tool for devices via fieldbus protocols and Endress+Hauser service protocols.</p> <p>DeviceCare is the tool developed by Endress+Hauser for the configuration of Endress+Hauser devices. All smart devices in a plant can be configured via a point-to-point or point-to-bus connection. The user-friendly menus enable transparent and intuitive access to the field devices.</p> <p> For details, see Operating Instructions BA00027S</p>

## System components

Accessories	Description
Display RIA15	It is integrated in the 4 to 20 mA or HART® loop and transmits the measuring signal or HART® process variables in digital form. The process display unit does not require an external power supply. It is powered directly from the current loop.  For details, see the "Technical Information" document TI01043K
Memograph M, RSG45	Advanced Data Manager with tamper-proof data storage and access (FDA 21 CFR 11) HART® gateway functionality; Up to 40 HART® devices connected at a time Communication capabilities: Modbus, Profibus DP, PROFINET, EtherNet/IP.  For details, see the "Technical Information" document TI01180R

## Supplementary documentation

The following types of documentation are available on the product pages and in the Download Area of the Endress+Hauser website ([www.endress.com/downloads](http://www.endress.com/downloads)) (depending on the selected device version):

Document	Purpose and content of the document
Technical Information (TI)	<b>Planning aid for your device</b> The document contains all the technical data on the device and provides an overview of the accessories and other products that can be ordered for the device.
Brief Operating Instructions (KA)	<b>Guide that takes you quickly to the 1st measured value</b> The Brief Operating Instructions contain all the essential information from incoming acceptance to initial commissioning.
Operating Instructions (BA)	<b>Your reference document</b> The Operating Instructions contain all the information that is required in various phases of the life cycle of the device: from product identification, incoming acceptance and storage, to mounting, connection, operation and commissioning through to troubleshooting, maintenance and disposal.
Description of Device Parameters (GP)	<b>Reference for your parameters</b> The document provides a detailed explanation of each individual parameter. The description is aimed at those who work with the device over the entire life cycle and perform specific configurations.
Safety Instructions (XA)	Depending on the approval, Safety Instructions (XA) are supplied with the device. The Safety Instructions are an integral part of the Operating Instructions.  Information on the Safety Instructions (XA) that are relevant for the device is provided on the nameplate.
Supplementary device-dependent documentation (SD/FY)	Always comply strictly with the instructions in the relevant supplementary documentation. The supplementary documentation is an integral part of the device documentation.



---

---

---



[www.addresses.endress.com](http://www.addresses.endress.com)

---