

EJT1

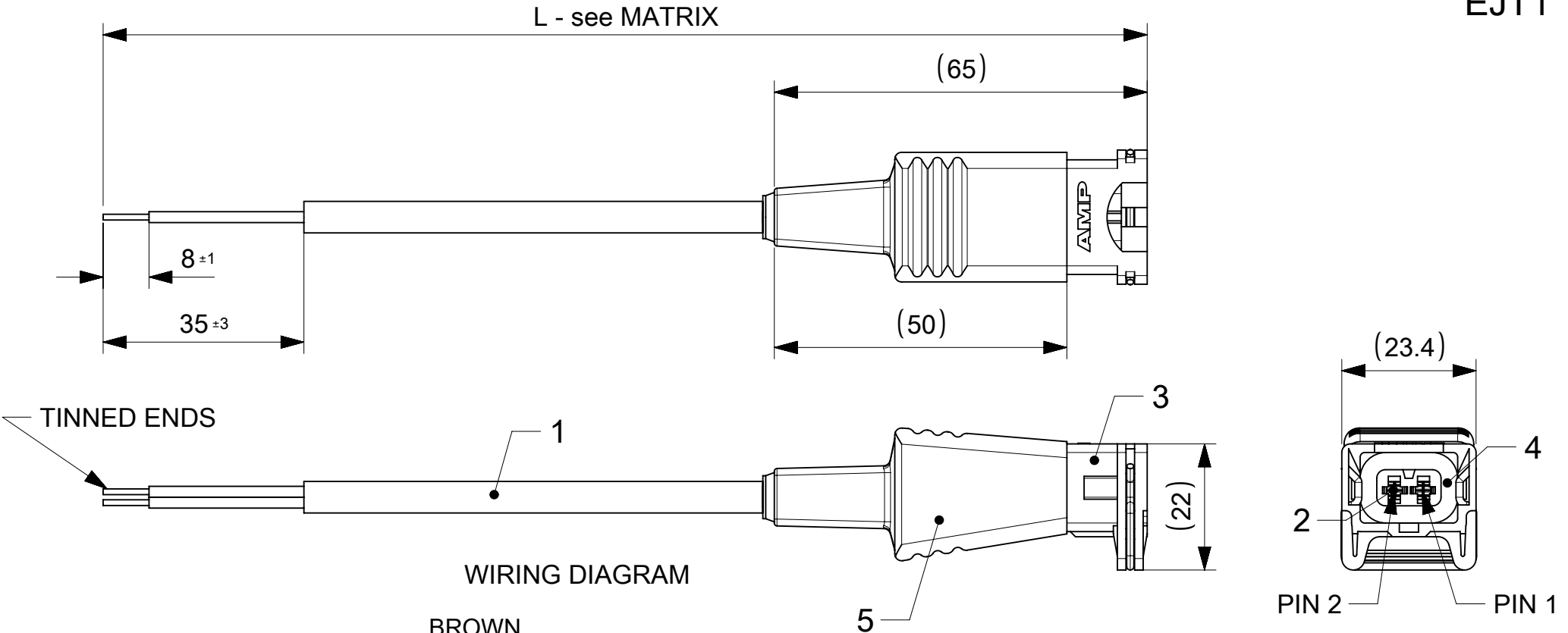

BILL OF MATERIALS

ITEM	QTY.	DESCRIPTION	MATERIAL	FINISH/COLOR
1	-	CABLE	SEE MATRIX	-
2	2	CONTACT FEMALE	PH. BRONZE	-
3	1	HOUSING 2P	PA6.6	BLACK
4	1	GASKET	SILICONE	WHITE
5	-	MOULDING MATERIAL	PP	BLACK

THIS DRAWING CONTAINS INFORMATION THAT IS PROPRIETARY TO MOLEX ELECTRONIC TECHNOLOGIES, LLC AND SHOULD NOT BE USED WITHOUT WRITTEN PERMISSION									
FUNCTIONAL SYMBOLS	DIMENSION UNITS	SCALE	CURRENT REV DESC:						
$\nabla_A = 0$	mm	1:1	EC NO: 681912 DRWN: APAWLAK01 2021/10/12 CHK'D: RSILLER 2021/10/19 APPR: RSILLER 2021/10/19 INITIAL REVISION: DRWN: APAWLAK01 2021/10/12 APPR: RSILLER 2021/10/19						
$\nabla_E = 0$	GENERAL TOLERANCES (UNLESS SPECIFIED)								
$\nabla_P = 0$	ANGULAR TOL	± °							
DIVISIONAL SYMBOLS	4 PLACES	±							
	3 PLACES	±	DOCUMENT NUMBER: 1210460005 DOC TYPE: PSD DOC PART: 000 REVISION: A						
	2 PLACES	±	DRAFT WHERE APPLICABLE MUST REMAIN WITHIN DIMENSIONS THIRD ANGLE PROJECTION DRAWING: A4-SIZE SERIES: 121046 MATERIAL NUMBER: SEE SHEET 2 CUSTOMER: GENERAL MARKET SHEET NUMBER: 1 OF 2						
	1 PLACE	±							
	0 PLACES	±							

molex

JUNIOR TIMER 2P FE STR EJT1XXXXXX

PRODUCT CUSTOMER DRAWING

DOCUMENT NUMBER: 1210460005
 DOC TYPE: PSD
 DOC PART: 000
 REVISION: A

DRAFT WHERE APPLICABLE MUST REMAIN WITHIN DIMENSIONS

THIRD ANGLE PROJECTION

DRAWING: A4-SIZE

SERIES: 121046

MATERIAL NUMBER: SEE SHEET 2

CUSTOMER: GENERAL MARKET

SHEET NUMBER: 1 OF 2

PART No MATRIX

E J T 1 X X X X X X

JUNIOR CONNECTORS

CONNECTOR TYPE:
1 - 2 WIRES, STRAIGHT

CABLE TYPE:
B3 - PUR BLACK 2x18AWG
N2 - PVC BLACK 2x0.5mm²
N3 - PVC BLACK 2x0.75mm²
P2 - PUR BLACK 2x0.5mm²
P3 - PUR BLACK 2x0.75mm²

HEAD COLOR:
N - BLACK
A - UL BLACK

CABLE LENGTH [cm]
050 = 50cm
300 = 300cm
10K = 1000cm

PART LIST

MOLEX PN	ENGINEERING NO	L±TOL. [mm]
1210460005	EJT1P3N200	2000±30
1210460006	EJT1P3N500	5000±40
1210460008	EJT1P3N300	3000±30
1210460009	EJT1P2N100	1000±20
1210460011	EJT1P3N100	1000±20
1210460012	EJT1P3N800	8000±50
1210460013	EJT1N3N150	1500±30
1210460014	EJT1P2N300	3000±30
1210460015	EJT1P3N150	1500±30
1210460024	EJT1P2N400	4000±40
1210460025	EJT1N3N100	1000±20
1210460026	EJT1P2N600	6000±50
1210460027	EJT1P3N10K	10000±50
1210460028	EJT1N3N200	2000±30
1210460034	EJT1P2N10K	10000±50
1210560056	EJT1N2N300	3000±30
1210560201	EJT1N2N100	1000±20
1210560249	EJT1B3A500	5000±40

TABLE OF LENGHT TOLERANCES

OVER	UP TO AND INCLUDING	TOLERANCE
0	1000	±20
1000	3000	±30
3000	5000	±40
5000	10000	±50
10000	15000	±100
15000	20000	±150
20000		±L/100

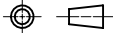
FUNCTIONAL SYMBOLS $\frac{F}{A} = 0$ $\frac{F}{E} = 0$ $\frac{F}{P} = 0$	THIS DRAWING CONTAINS INFORMATION THAT IS PROPRIETARY TO MOLEX ELECTRONIC TECHNOLOGIES, LLC AND SHOULD NOT BE USED WITHOUT WRITTEN PERMISSION		DIMENSION UNITS: mm SCALE: 1:1		CURRENT REV DESC: EC NO: 681912 DRWN: APAWLAK01 2021/10/12 CHK'D: RSILLER 2021/10/19 APPR: RSILLER 2021/10/19	 JUNIOR TIMER 2P FE STR EJT1XXXXXX			
	GENERAL TOLERANCES (UNLESS SPECIFIED) ANGULAR TOL ± °		INITIAL REVISION: DRWN: APAWLAK01 2021/10/12 APPR: RSILLER 2021/10/19						PRODUCT CUSTOMER DRAWING
DIVISIONAL SYMBOLS 4 PLACES ± 3 PLACES ± 2 PLACES ± 1 PLACE ± 0 PLACES ±	DRAFT WHERE APPLICABLE MUST REMAIN WITHIN DIMENSIONS		THIRD ANGLE PROJECTION	DRAWING: A4-SIZE	SERIES: 121046	DOCUMENT NUMBER: 1210460005	DOC TYPE: PSD	DOC PART: 000	REVISION: A
				MATERIAL NUMBER: SEE PART LIST	CUSTOMER: GENERAL MARKET	SHEET NUMBER: 2 OF 2			

DOCUMENT STATUS | P1 | RELEASE DATE | 2021/10/19 12:55:13

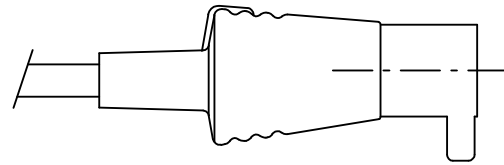

SCHEMAT ELEKTRYCZNY
ELECTRICAL DIAGRAM

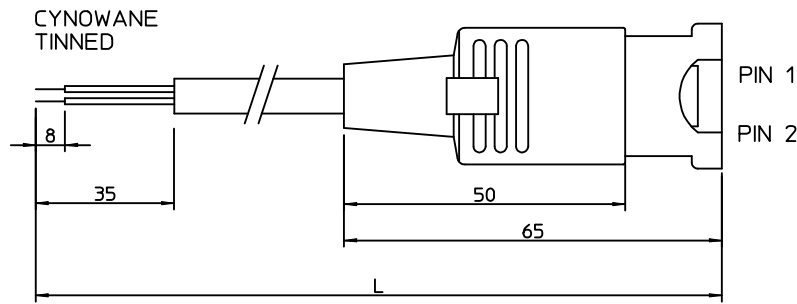
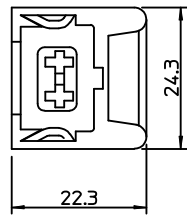
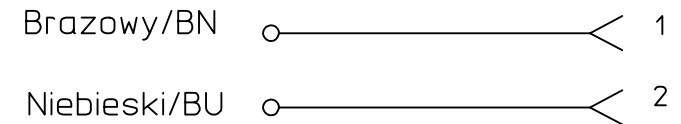

PATRZ UWAGA 1
SEE NOTE 1

UWAGI:

1. DŁUGOSC PATRZ ARKUSZ 2.

NOTES:

1. LENGHT SEE SHEET 2.

ORIGINAL RELEASE	EC NO:	DRWN: MWOLSZCZAK 2009/05/28	QUALITY SYMBOLS	GENERAL TOLERANCES (UNLESS SPECIFIED)		DIMENSION STYLE INCH ONLY		SCALE 1:1	DESIGN UNITS METRIC	FIRST ANGLE PROJECTION		
	REV	CHYKD: MDABROWSKA 2009/06/08		mm	INCH	DRAWN BY	DATE	TITLE	MPM EJTXXXXXX			
	A	APPR: COGRODNIK 2009/06/16		4 PLACES	± ---	± ---	MLEVYTSKY	2009/04/20	MOLEX INCORPORATED			
				3 PLACES	± ---	± ---	CHECKED BY	DATE				
			2 PLACES	± ---	± ---	APPROVED BY	DATE	EJTXXXXXX		1 OF 4		
			1 PLACE	± ---	± ---	MWOLSZCZAK	2009/04/20	THIS DRAWING CONTAINS INFORMATION THAT IS PROPRIETARY TO MOLEX INCORPORATED AND SHOULD NOT BE USED WITHOUT WRITTEN PERMISSION				
			ANGULAR ± ---°		DRAFT WHERE APPLICABLE MUST REMAIN WITHIN DIMENSIONS		SIZE A3					

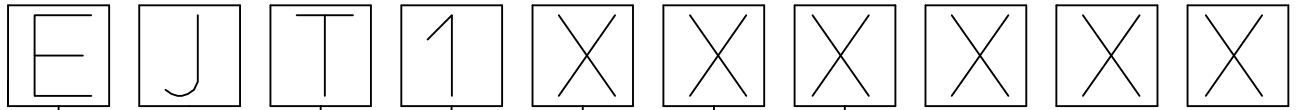

JUNIOR KONEKTOR

TYP KONEKTORA:

1 - PROSTY, 2 PINY, POJEDYNCZY

3 - PROSTY, 4 PINY, POJEDYNCZY

E - 90 ST, 2 PINY, POJEDYNCZY

G - 90 ST, 2 PINY, POJEDYNCZY

A - PROSTY, 2 PINY, STRONA 2 - M12

TYP KABLA/CABLE TYPE
PATRZ TABELA 1/SEE TABLE 1

KOLOR MOULDINGU/HEAD COLOUR:
G-SZARY/GREY,
N-CZARNY/BLACK,
T-PRZEZROCZYSTY/TRANSPARENT,
A-CZARNY/BLACK,
B-SZARY/GREY.

DLUGOSC KABLA W CM/CABLE LENGTH IN CM
NP:050=50 CM, 300=300 CM.

ORIGINAL RELEASE	EC NO:	DRWN:MWOLSZCZAK 2009/05/28	QUALITY SYMBOLS	GENERAL TOLERANCES (UNLESS SPECIFIED)		DIMENSION STYLE MM ONLY		SCALE ---	DESIGN UNITS METRIC	FIRST ANGLE PROJECTION			
	REV	CHYKD:MDABROWSKA 2009/06/08		mm	INCH	DRAWN BY	DATE	TITLE					
	A	APPR:GOGRODNIK 2009/06/16		4 PLACES	± ---	± ---	MLEVYTSKY	2009/04/20	MPM EJT1XXXXXX				
				3 PLACES	± ---	± ---	CHECKED BY	DATE	MOLEX INCORPORATED				
				2 PLACES	± ---	± ---	MDABROWSKA	2009/04/20					
		1 PLACE	± ---	± ---	APPROVED BY	DATE	DOCUMENT NO.						
					MWOLSZCZAK	2009/04/20	EJT1XXXXXX						
					ANGULAR ± ---°		MATERIAL NO.		SHEET NO.				
					DRAFT WHERE APPLICABLE MUST REMAIN WITHIN DIMENSIONS		SIZE A3		THIS DRAWING CONTAINS INFORMATION THAT IS PROPRIETARY TO MOLEX INCORPORATED AND SHOULD NOT BE USED WITHOUT WRITTEN PERMISSION				

TABELA 2 KABLE/TABLE 2 CABLES

MOLEX PN	mPm	Code	PRZEZ	PRZEKROJ	MATERIAL	KOLOR/COLOUR	SREDNICA Ø	DIN A-B	DIN C
1210180080	I	0	3	1 mm2	PVC CEI 2022 II O.R.	Szary/Grey RAL7035	-	-	-
1210180467	A	2	2	20 AWG	PVC CSA/UL 2661	Czarny/Black	5,5+/-0,2 mm	OK.	OK.
-	A	2	3	20 AWG	PVC CSA/UL 2661	Czarny/Black	5,6+/-0,2 mm	OK.	OK.
1210180394	A	2	4	20 AWG	PVC CSA/UL 2661	Czarny/Black	6,2+/-0,2 mm	OK.	OK.
-	A	2	5	20 AWG	PVC CSA/UL 2661	Czarny/Black	7+/-0,2 mm	OK.	
1210180297	B	2	2	20 AWG	PUR CSA/UL 20668	Czarny/Black	5,5+/-0,2 mm	OK.	OK.
1210180126	B	2	3	20 AWG	PUR CSA/UL 20668	Czarny/Black	5,6+/-0,2 mm	OK.	OK.
1210180387	B	2	4	20 AWG	PUR CSA/UL 20668	Czarny/Black	6,2+/-0,2 mm	OK.	OK.
-	B	2	5	20 AWG	PUR CSA/UL 20668	Czarny/Black	7+/-0,2 mm	OK.	
1210180122	D	2	3	0,5 mm2	PVC T12 CEI 20-20	Szary/Grey	-	-	-
-	F	2	3	0,5 mm2	CNOMO	Szary/Grey RAL7000	5,5+/-0,2 mm	OK.	OK.
1210180047	I	2	2	0,5 mm2	PVC CEI 2022 II O.R.	Szary/Grey RAL7035	5,5+/-0,2 mm	OK.	OK.
-	I	2	3	0,5 mm2	PVC CEI 2022 II O.R.	Szary/Grey RAL7035	5,5+/-0,2 mm	OK.	OK.
1210180146	I	2	4	0,5 mm2	PVC CEI 2022 II O.R.	Szary/Grey RAL7035	6,5+/-0,2 mm	OK.	
1210180177	I	2	5	0,5 mm2	PVC CEI 2022 II O.R.	Szary/Grey RAL7035	7+/-0,2 mm	OK.	
1210180022	N	2	2	0,5 mm2	PVCH03	Czarny/Black	5,1+ 0,2-0 mm	OK.	OK.
1210180064	N	2	3	0,5 mm2	PVCH03	Czarny/Black	5,4+ 0,2-0 mm	OK.	OK.
1210180153	N	2	4	0,5 mm2	PVCH03	Czarny/Black	5,75+0,2-0 mm	OK.	OK.
1210180046	P	2	2	0,5 mm2	PUR - BLEND	Czarny/Black	5,5+/-0,2 mm	OK.	OK.
-	P	2	3	0,5 mm2	PUR - BLEND	Czarny/Black	5,5+/-0,2 mm	OK.	OK.
1210180302	P	2	4	0,5 mm2	PUR - BLEND	Czarny/Black	-	-	-
-	P	2	5	0,5 mm2	PUR - BLEND	Czarny/Black	7+/-0,2 mm	OK.	OK.
1210180409	A	3	2	18 AWG	PVC CSA/UL 2661	Czarny/Black	6,5+/-0,2 mm	OK.	
1210180129	A	3	3	18 AWG	PVC CSA/UL 2661	Czarny/Black	6,5+/-0,2 mm	OK.	
1210180159	A	3	4	18 AWG	PVC CSA/UL 2661	Czarny/Black	7+/-0,2 mm	OK.	
-	A	3	5	18 AWG	PVC CSA/UL 2661	Czarny/Black	7,8+/-0,2 mm	OK.	
1210180351	B	3	2	18 AWG	PUR CSA/UL 20668	Czarny/Black	6,5+/-0,2 mm	OK.	
1210180127	B	3	3	18 AWG	PUR CSA/UL 20668	Czarny/Black	6,5+/-0,2 mm	OK.	
1210180127	B	3	4	18 AWG	PUR CSA/UL 20668	Czarny/Black	7+/-0,2 mm	OK.	
-	B	3	5	18 AWG	PUR CSA/UL 20668	Czarny/Black	7,8+/-0,2 mm	OK.	
1210180073	D	3	3	0,75 mm2	PVC T12 CEI 20-20	Szary/Grey	-	-	-
1210180145	D	3	4	0,75 mm2	PVC T12 CEI 20-20	Szary/Grey	-	-	-
1210180120	I	3	3	0,75 mm2	PVC CEI 2022 II O.R.	Szary/Grey RAL7035	-	-	-
1210180143	I	3	4	0,75 mm2	PVC CEI 2022 II O.R.	Szary/Grey RAL7035	-	-	-
1210180032	N	3	2	0,75 mm2	PVCH05	Czarny/Black	6,2+ 0,2-0 mm	OK.	
1210180069	N	3	3	0,75 mm2	PVCH05	Czarny/Black	6,6+0,2-0 mm	OK.	
-	N	3	4	0,75 mm2	PVCH05	Czarny/Black	7,15+0,2-0 mm	OK.	
1210180174	N	3	5	0,75 mm2	PVCH05	Czarny/Black	8,0+0,2-0 mm	OK.	
-	P	3	2	0,75 mm2	PUR - BLEND	Czarny/Black	6,5+/-0,2 mm	OK.	

TABELA 2 KABLE/TABLE 2 CABLES

MOLEX PN	mPm	Code	PRZEZ	PRZEKROJ	MATERIAL	KOLOR/COLOUR	SREDNICA Ø	DIN A-B	DIN C
1210180071	P	3	3	0,75 mm2	PUR - BLEND	Czarny/Black	6,5+/-0,2 mm	OK.	
1210180152	P	3	4	0,75 mm2	PUR - BLEND	Czarny/Black	7+/-0,2 mm	OK.	
1210180384	R	3	3	0,75 mm2	TPR HAL. FREE	Czarny/Black	6,5+/-0,2 mm	OK.	
1210180094	T	3	3	0,75 mm2	PUR CSA/UL	Żółty/Yellow	-	-	-
1210180309	Y	3	3	0,75 mm2	SIL/0300	Czerwony/Red	6,5+/-0,2 mm	-	-
1210180081	F	4	3	1 mm2	CNOMO	Szary/Grey RAL7000	-	-	-
-	F	4	4	1 mm2	CNOMO	Szary/Grey RAL7000	7,1+0,2-0 mm	OK.	
1210180042	I	4	2	1 mm2	PVC CEI 2022 II O.R.	Szary/Grey RAL7035	7,1+0,2-0 mm	OK.	
1210180079	I	4	3	1 mm2	PVC CEI 2022 II O.R.	Szary/Grey RAL7035	7,1+0,2-0 mm	OK.	
1210180036	N	4	2	1 mm2	PVCH05	Czarny/Black	6,5+0,2-0 mm	OK.	
1210180082	N	4	3	1 mm2	PVCH05	Czarny/Black	6,9+0,2-0 mm	OK.	
1210180117	R	4	3	1 mm2	TPR HAL. FREE	Czarny/Black	-	-	-
1210180085	N	5	3	1,5 mm2	PVCH05	Czarny/Black	8,3+0,2-0 mm	OK.	
1210180313	I	6	2	0,35 mm2	PVC CEI 2022 II O.R.	Szary/Grey RAL7035	-	-	-
-	A	7	3	20 AWG	PVC CSA/UL 2661	Żółty/Yellow	5,6+/-0,2 mm	OK.	OK.
1210180149	I	9	4	0,75 mm2	PVC CEI 2022 II O.R.	Szary/Grey RAL7035	-	-	-

TABELA 1 TYPY KABLI/TABLE 1 CABLES TYPE

Znakowanie /Code	Rodzaje kabla /Cable types	Właściwości /Features	Przekroje /Stranding
N	PVC	Kabel z dobrą rezystancją w wodzie ale słabą w oleju./Application general purpose cable which has good resistance to water, but usually poor oil resistance.	0,5 mm2 = 15 x 0,20 0,75 mm2 = 21 x 0,20 1 mm2 = 28 x 0,20
I	PVC	Zatwierdzone przez IEC 332-2A, samogaszący./Approved to IEC 332-2A, flame retardant and self extinguishing. Limited resistant to mineral oils.	0,5 mm2 = 28 x 0,15 0,75 mm2 = 42 x 0,15 1 mm2 = 32 x 0,20
P	PVC	Dobra rezystancja w olejach i chemikaljach./Offer good resistance to oil and chemicals. Can swell when constantly immersed in water.	0,5 mm2 = 28 x 0,15 0,75 mm2 = 42 x 0,15 1 mm2 = 32 x 0,20
A	PVC	Zatwierdzony porzez CSA-UL 2661. Dobra rezystancja na wode słaba na olej./ Approved to CSA-UL 2661, application general purpose cable which has good resistance to water, but usually poor oil resistance.	20 AWG = 32 x 0,15 18 AWG = 52 x 0,15
B	PVC	Zatwierdzony przez CSA-UL 20668, bardzo dobra rezystancja w oleju i chemikaljach./ Approved to CSA-UL 20668, very good resistance to oil and chemicals.	20 AWG = 32 x 0,15 18 AWG = 52 x 0,15

ORIGINAL RELEASE EC NO: DRWIN: MWOLSZCZAK 2009/05/28 CHYKD: MDABROWSKA 2009/06/08 APPR: GOGRODNIK 2009/06/16	QUALITY SYMBOLS	GENERAL TOLERANCES (UNLESS SPECIFIED)	DIMENSION STYLE MM ONLY	SCALE ---	DESIGN UNITS METRIC	FIRST ANGLE PROJECTION
	DESCRIPTION	mm	INCH	DRAWN BY	DATE	TITLE
	REV	4 PLACES ± --- ± ---	MLEVYTSKYY	2009/04/20	MPM EJT1XXXXXX	
		3 PLACES ± --- ± ---	CHECKED BY	DATE		

ANGULAR ± ---°	APPROVED BY	DATE	MATERIAL NO.
	MWOLSZCZAK	2009/04/20	
DRAFT WHERE APPLICABLE MUST REMAIN WITHIN DIMENSIONS	SEE DRAWING	DOCUMENT NO.	
	SIZE	EJT1XXXXXX	
	A3	3 OF 4	

THIS DRAWING CONTAINS INFORMATION THAT IS PROPRIETARY TO MOLEX INCORPORATED AND SHOULD NOT BE USED WITHOUT WRITTEN PERMISSION	
---	--

MOLEX INCORPORATED	
EJT1XXXXXX	

PN KEY

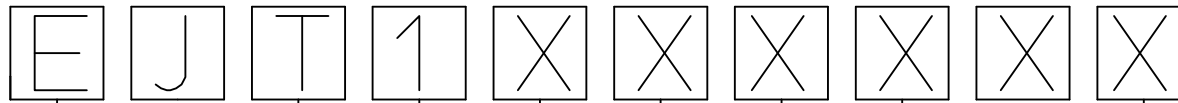

JUNIOR CONNECTORS

CONNECTOR TYPE: _____

1 - 2 WIRES, STRAIGHT

CABLE TYPE, SEE SHEET 2, CHART 1 AND CHART 2 _____

HEAD COLOR: _____

G=GRAY; N=BLACK; T=TRANSPARENT; A=CSA-UL BLACK; B=CSA-UL GRAY

CABLE LENGTH IN CENTIMETRES: _____

EXAMPLE: 050=50 CM, 300=300 CM.

Table of length tolerances [mm]

Over	Up to and including	Tolerance
0	1000	±20
1000	3000	±30
3000	5000	±40
5000	10000	±50
10000	15000	±100
15000	20000	±150
20000		±L/100

TABLE 1

MOLEX PN	Engineering No.	L [mm]
1210460005	EJT1P3N200	2000
1210460006	EJT1P3N500	5000
1210460008	EJT1P3N300	3000
1210460009	EJT1P2N100	1000
1210460011	EJT1P3N100	1000
1210460012	EJT1P3N800	8000
1210460013	EJT1N3N150	1500
1210460014	EJT1P2N300	3000
1210460015	EJT1P3N150	1500
1210460024	EJT1P2N400	4000
1210460025	EJT1N3N100	1000
1210460026	EJT1P2N600	6000
1210460027	EJT1P3N10K	10000
1210460028	EJT1N3N200	2000
1210460034	EJT1P2N10K	10000
1210560056	EJT1N2N300	3000
1210560201	EJT1N2N100	1000

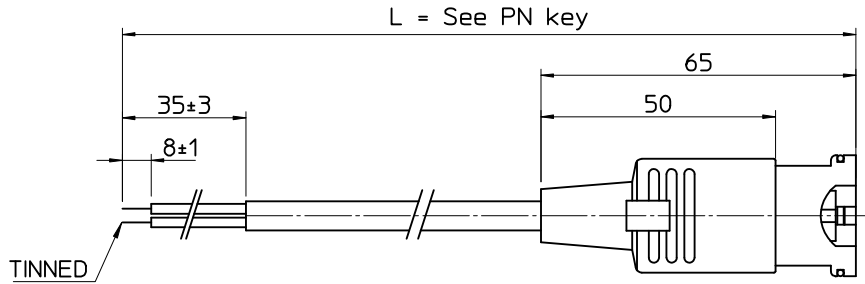

ELECTRICAL DIAGRAM

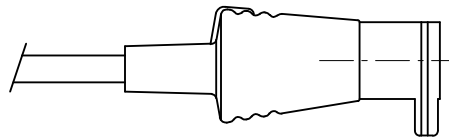
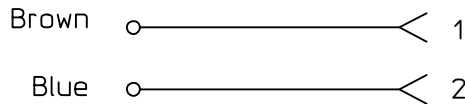

Face View

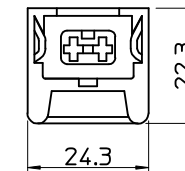

2
1
2
1

NOTES:
1. Dimensions without tolerances are referential

ORIGINAL RELEASE EC NO: IPG2016-0461 DRWN: JMARSZALEK 2014/05/31 CHKD: APPR: MIWASIECZKO 2015/09/28	QUALITY SYMBOLS	GENERAL TOLERANCES (UNLESS SPECIFIED)	DIMENSION STYLE	SCALE	DESIGN UNITS	THIRD ANGLE PROJECTION
	▼=0 □=0	mm INCH 4 PLACES ± --- ± --- 3 PLACES ± --- ± --- 2 PLACES ± --- ± --- 1 PLACE ± --- ± --- 0 PLACE ± --- ± ---	MM ONLY	-	METRIC	
	DESCRIPTION	ANGULAR ± --- °	DRAWN BY	DATE	TITLE	
	REV	DRAFT WHERE APPLICABLE MUST REMAIN WITHIN DIMENSIONS	JMARSZALEK	2014/05/31	EJT1XXXXXX JUNIOR TIMER 2P FE STR	
			CHECKED BY	DATE		
			APPROVED BY	DATE		
			MIWASIECZKO	2015/09/28		
			MATERIAL NO.	DOCUMENT NO.		
			SEE PN KEY	SD-121046-002		
			SIZE			
			A3			
			THIS DRAWING CONTAINS INFORMATION THAT IS PROPRIETARY TO MOLEX INCORPORATED AND SHOULD NOT BE USED WITHOUT WRITTEN PERMISSION			

TABLE 2 - CABLES

TABLE 2 - CABLES

Molex PN Raw cable	Cable type	Cable code	Wires no.	Cross Section	Jacket material	Jacket color	Diameter Ø [mm]	Wire colors
1210180384	R	3	3	0.75 mm ²	TPR HAL. FREE	Black	6.5±0.2	BN, BU, GN/YE
1210180094	T	3	3	0.75 mm ²	PUR CSA/UL 20668	Yellow	6.5±0.2	BN, BU, GN/YE
1210180309	Y	3	3	0.75 mm ²	SILICONE RUBBER	Red	6.5±0.2	BN, BU, GN/YE
1210180081	F	4	3	1 mm ²	PVC CNOMO	Grey	7.1+0.2/-0	BK1, BK2, GN/YE
1210180042	I	4	2	1 mm ²	PVC CEI 2022 II O.R.	Grey	7.1+0.2/-0	BN, BU
1210180079	I	4	3	1 mm ²	PVC CEI 2022 II O.R.	Grey	7.1+0.2/-0	BN, BU, GN/YE
1210180036	N	4	2	1 mm ²	PVC H05VV-F	Black	6.5±0.2	BN, BU
1210180082	N	4	3	1 mm ²	PVC H05VV-F	Black	6.9±0.2	BN, BU, GN/YE
1210180117	R	4	3	1 mm ²	TPR HAL. FREE	Black	7.1±0.2	BN, BU, GN/YE
1210180085	N	5	3	1.5 mm ²	PVC H05VV-F	Black	7.9±0.2	BN, BU, GN/YE
1210180313	I	6	2	0.35 mm ²	PVC CEI 2011	Grey	4.8±0.2	BN, WH
1210180149	I	9	4	0.75 mm ²	PVC CEI 2022 II	Grey	7.3±0.2	BN, BU, BK, GN/YE

TABLE 1 - TYPES OF CABLES

Code	Cable types	Features	Cross Section
N	PVC	Application general purpose cable which has good resistance to water, but usually poor oil resistance.	0.5 mm ² 0.75 mm ² 1 mm ²
I	CEI	Approved to IEC 332-2A, flame retardant and self extinguishing. Limited resistant to mineral oils.	0.5 mm ² 0.75 mm ² 1 mm ²
P	PUR	Offer good resistance to oil and chemicals. Can swell when constantly immersed in water.	0.5 mm ² 0.75 mm ² 1 mm ²
A	PVC CSA-UL	Approved to CSA-UL 2661, application general purpose cable which has good resistance to water, but usually poor oil resistance.	20 AWG 18 AWG
B	PUR CSA-UL	Approved to CSA-UL 20668, very good resistance to oil and chemicals.	20 AWG 18 AWG

ORIGINAL RELEASE EC NO: IPG2016-0461 DRWN: JMARSZALEK 2014/05/31 CHKD: APPR: MIWASIECZKO 2015/09/28	QUALITY SYMBOLS ▽=0 ◻=0	GENERAL TOLERANCES (UNLESS SPECIFIED)		DIMENSION STYLE MM ONLY		SCALE -	DESIGN UNITS METRIC	THIRD ANGLE PROJECTION					
				mm	INCH	DRAWN BY JMARSZALEK	DATE 2014/05/31	TITLE EJT1XXXXXX JUNIOR TIMER 2P FE STR					
				4 PLACES	± ---	± ---	CHECKED BY	DATE					
				3 PLACES	± ---	± ---	APPROVED BY MIWASIECZKO 2015/09/28					DOCUMENT NO. SD-121046-002	
				2 PLACES	± ---	± ---	MATERIAL NO. SEE PN KEY					SHEET NO. 2 OF 2	
		1 PLACE	± ---	± ---	DRAFT WHERE APPLICABLE MUST REMAIN WITHIN DIMENSIONS								
		0 PLACE	± ---	± ---	THIS DRAWING CONTAINS INFORMATION THAT IS PROPRIETARY TO MOLEX INCORPORATED AND SHOULD NOT BE USED WITHOUT WRITTEN PERMISSION								

PART No MATRIX

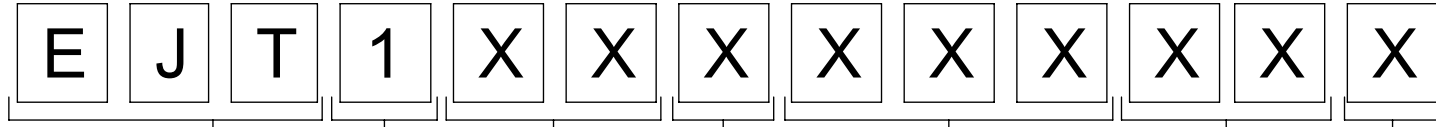

JUNIOR CONNECTORS

CONNECTOR TYPE :
1 - STRAIGHT, 2 WIRES, SINGLE ENDED

CABLE TYPE

CABLE LENGTH [cm]
050 = 50cm
300 = 300cm
10K = 1000cm

HEAD COLOR
N- BLACK, A-CSA-UL BLACK

INTERNAL CIRCUIT:
SEE WIRING CONFIGURATION

VOLTAGE AND LED COLOUR

RED LED	GREEN LED	YELLOW LED
1 = 12V	A = 12V	G = 12V
2 = 24V	B = 24V	H = 24V
3 = 48V	C = 48V	K = 48V
4 = 115V	D = 115V	L = 115V
5 = 230V	E = 230V	M = 230V

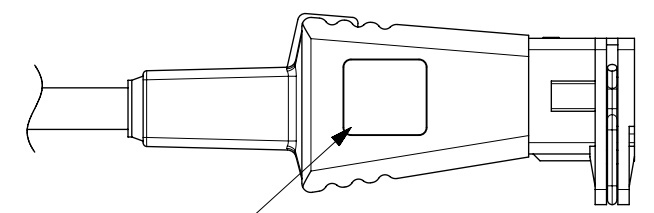
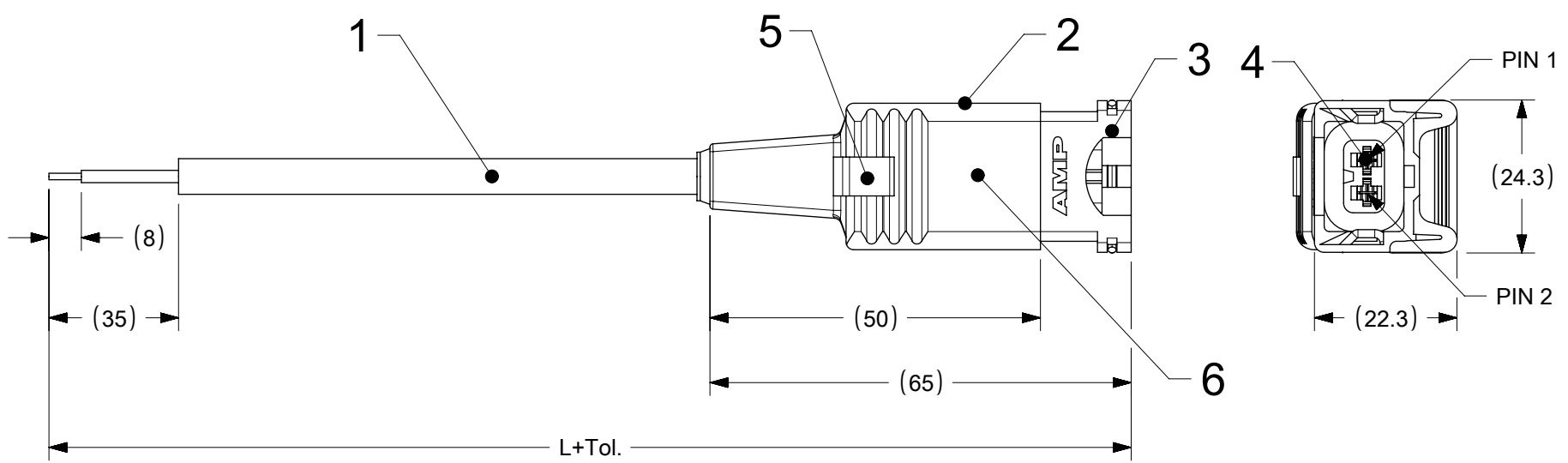

CIRCUIT WHITE PRINTOUT

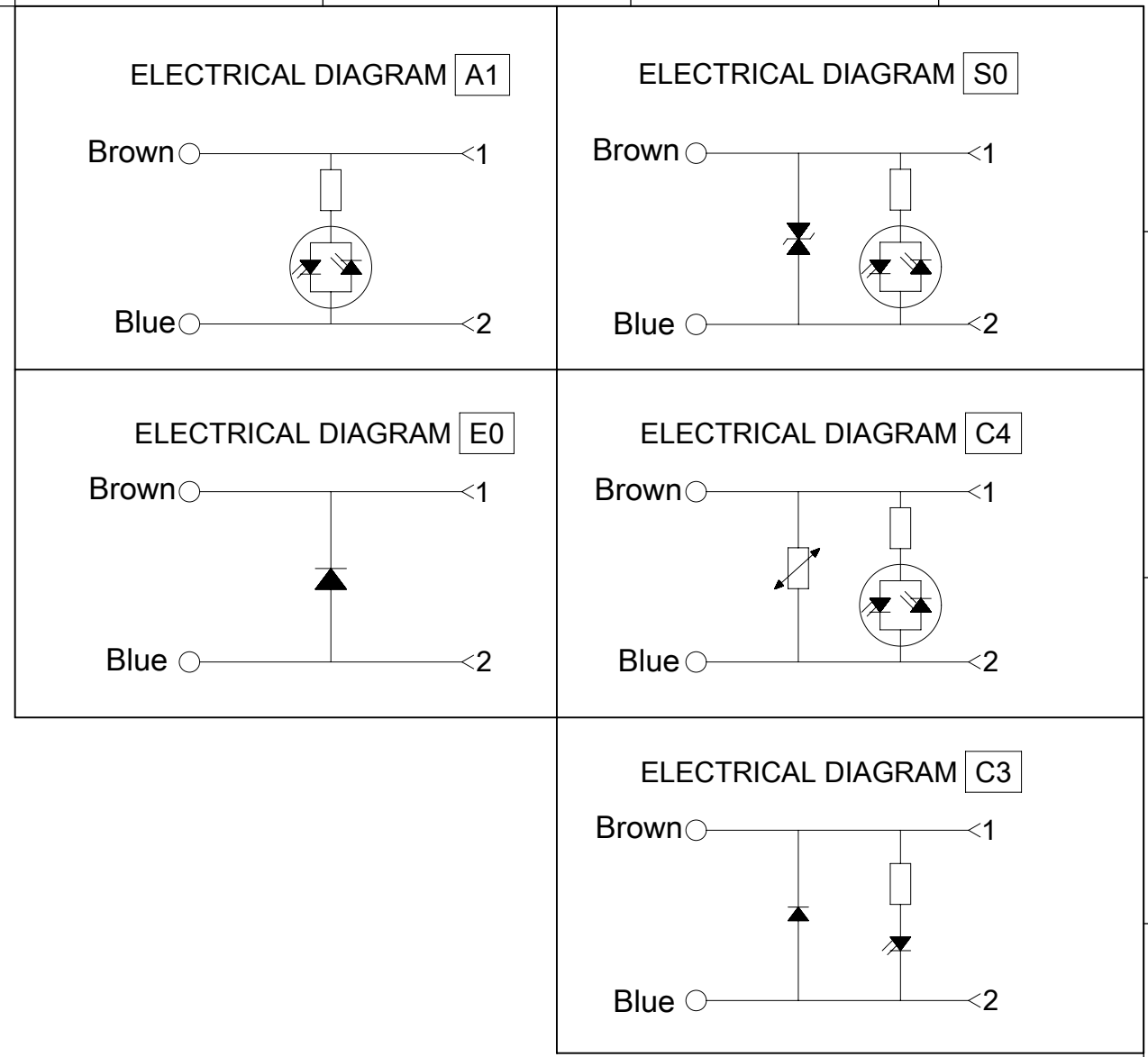

CIRCUIT CHARACTERISTIC

MOLEX P/N	ENG No.	CIRCUIT	RATED VOLTAGE	LED COLOR	VOLTAGE PEAK PROTECTION (Bidirectional)*		
					BREAKDOWN VOLTAGE (typ.) @ 25°C	MAXIMUM CLAMPING VOLTAGE	MAXIMUM PEAK PULSE CURRENT @ 25°C
1210560007	EJT1P3N300S0H	S0	24V AC/DC	YELLOW	75V	100V	4A
1210560023	EJT1P3N500S0H						
1210560045	EJT1P3N10KS0H						
1210560095	EJT1P3N150S0H						
1210560238	EJT1P3N15KS0H						

* PROTECTION FROM VOLTAGE TRANSIENTS ACCORDING 10/1000µs WAVEFORM TEST (T_a = 25°C)
PARAMETERS ONLY VALID FOR LISTED PART NUMBERS(P/N)
OTHER P/NS WITH SAME CIRCUIT AND VOLTAGE RATING COULD HAVE A DIFFERENT CHARACTERISTIC

BILL OF MATERIALS

ITEM	QTY.	DESCRIPTION	MATERIAL	FINISH/COLOR
6	-	ELECTRONIC COMPONENTS		
5	1	LENS	-	TRANSPARENT
4	2	CONTACT	PH. BRONZE	
3	1	HOUSING JUNIOR	PA6.6 GVF 30	BLACK
2	-	MOULDING MATERIAL	PP	BLACK
1	-	CABLE	SEE SHEET 2	SEE SHEET 2
ITEM	QTY.	DESCRIPTION	MATERIAL	FINISH/COLOR

DOCUMENT STATUS | P1 | RELEASE DATE | 2020/01/13 | 15:09:39

SYMBOLS	THIS DRAWING CONTAINS INFORMATION THAT IS PROPRIETARY TO MOLEX ELECTRONIC TECHNOLOGIES, LLC AND SHOULD NOT BE USED WITHOUT WRITTEN PERMISSION		CURRENT REV DESC: MIGRATED TO ECTR	
	DIMENSION UNITS	SCALE		
▽ = 0	mm	1:1		
▽ = 0	GENERAL TOLERANCES (UNLESS SPECIFIED)			
▽ = 0	ANGULAR TOL ± 1.0°			
▽ = 0	4 PLACES ±			
▽ = 0	3 PLACES ±			
▽ = 0	2 PLACES ± 0.05			
▽ = 0	1 PLACE ± 0.3			
▽ = 0	0 PLACES ± 0.5			
▽ = 0	DRAFT WHERE APPLICABLE MUST REMAIN WITHIN DIMENSIONS			
THIRD ANGLE PROJECTION		DRAWING	SERIES	MATERIAL NUMBER
B-SIZE		121056	SEE SHEET 2	CUSTOMER
SERIES		121056	CUSTOMER	SHEET NUMBER
B-SIZE		121056	GENERAL MARKET	1 OF 2



JUNIOR TIMER CONNECTORS
EJT1XXXXXXX

PRODUCT CUSTOMER DRAWING

DOCUMENT NUMBER | DOC TYPE | DOC PART | REVISION

SD-121056-002 | PSD | 001 | A1

MATERIAL NUMBER | CUSTOMER | SHEET NUMBER

SEE SHEET 2 | GENERAL MARKET | 1 OF 2

Molex PN Raw cable	Cable type	Cable code	Wires no.	Cross Section	Jacket material	Jacket color	Diameter Ø [mm]	Wire colors
1202091424	I	0	3	1 mm ²	PVC CEI 2022 II O.R.	Grey	7.6±0.2	BN, BU, GN/YE
1210180467	A	2	2	20 AWG	PVC CSA/UL 2661	Black	5.4±0.2	BN, BU
1210180128	A	2	3	20 AWG	PVC CSA/UL 2661	Black	5.6±0.2	BN, BU, GN/YE
1210180394	A	2	4	20 AWG	PVC CSA/UL 2661	Black	6.2±0.25	BN, BU, BK, GN/YE
1210180297	B	2	2	20 AWG	PUR CSA/UL 20668	Black	5.6±0.2	BN, BU
1210180126	B	2	3	20 AWG	PUR CSA/UL 20668	Black	5.6±0.2	BN, BU, GN/YE
1210180387	B	2	4	20 AWG	PUR CSA/UL 20668	Black	6.3±0.2	BN, BU, BK, GN/YE
1210180284	D	2	3	0.5 mm ²	PVC CEI 20-20	Grey	5.5+0.3/-0	BN, BU, GN/YE
1210180047	I	2	2	0.5 mm ²	PVC CEI 2022 II O.R.	Grey	5.5+0.3/-0	BN, BU
1210180284	I	2	3	0.5 mm ²	PVC CEI 2022 II O.R.	Grey	5.5+0.3/-0	BN, BU, GN/YE
1210180146	I	2	4	0.5 mm ²	PVC CEI 2022 II O.R.	Grey	6.5±0.2	BN, BU, BK, GN/YE
1210180177	I	2	5	0.5 mm ²	PVC CEI 2022 II O.R.	Grey	7.0 +0.3/-0	BN, BU, BK, WH, GN/YE
1210180022	N	2	2	0.5 mm ²	PVC H03VV-F	Black	5.2±0.2	BN, BU
1202092753	N	2	3	0.5 mm ²	PVC H03VV-F	Black	5.5±0.2	BN, BU, GN/YE
1210180153	N	2	4	0.5 mm ²	PVC H03VV-F	Black	5.9±0.3	BN, BU, BK, GN/YE
1210180046	P	2	2	0.5 mm ²	PUR - BLEND	Black	5.5±0.2	BN, BU
1202092439	P	2	3	0.5 mm ²	PUR - BLEND	Black	5.5 +0.3/-0	BN, BU, GN/YE
1210180302	P	2	4	0.5 mm ²	PUR - BLEND	Black	6.5±0.2	BN, BU, BK, GN/YE
1202092215	P	2	5	0.5 mm ²	PUR - BLEND	Black	7+0.3/-0.1	BN, BU, BK, WH, GN/YE
1210180409	A	3	2	18 AWG	PVC CSA/UL 2661	Black	6.2±0.25	BN, BU
1210180129	A	3	3	18 AWG	PVC CSA/UL 2661	Black	6.5±0.25	BN, BU, GN/YE
1210180159	A	3	4	18 AWG	PVC CSA/UL 2661	Black	7.0+0.3/-0	BN, BU, BK, GN/YE
1210180464	A	3	5	18 AWG	PVC CSA/UL 2661	Black	7.8±0.25	BN, BU, BK, WH, GN/YE
1210180351	B	3	2	18 AWG	PUR CSA/UL 20668	Black	6.2±0.2	BN, BU
1210180127	B	3	3	18 AWG	PUR CSA/UL 20668	Black	6.5±0.2	BN, BU, GN/YE
1210180160	B	3	4	18 AWG	PUR CSA/UL 20668	Black	7±0.2	BN, BU, BK, GN/YE
1210180463	B	3	5	18 AWG	PUR CSA/UL 20668	Black	7.8±0.25	BN, BU, BK, WH, GN/YE
1210180073	D	3	3	0.75 mm ²	PVC CEI 20-20	Grey	6.5±0.2	BN, BU, GN/YE
1210180145	D	3	4	0.75 mm ²	PVC CEI 20-20	Grey	7.1±0.2	BN, BU, BK, GN/YE
1202098206	I	3	2	0.75 mm ²	PVC CEI 2022 II O.R.	Grey	5.5±0.2	BK1, BK2
1210180120	I	3	3	0.75 mm ²	PVC CEI 2022 II O.R.	Grey	6.0±0.2	BK1, BK2, BK3
1210180143	I	3	4	0.75 mm ²	PVC CEI 2022 II O.R.	Grey	7.0±0.2	BN, BU, BK, GN/YE
1210180032	N	3	2	0.75 mm ²	PVC H05VV-F	Black	6.2±0.2	BN, BU
1210180069	N	3	3	0.75 mm ²	PVC H05VV-F	Black	6.5±0.2	BN, BU, GN/YE
1210180144	N	3	4	0.75 mm ²	PVC H05VV-F	Black	7.1±0.2	BN, BU, BK, GN/YE
1210180174	N	3	5	0.75 mm ²	PVC H05VV-F	Black	8.0+0.2/-0	BN, BU, BK, GY, GN/YE
1202094190	P	3	2	0.75 mm ²	PUR - BLEND	Black	6.5±0.2	BN, BU
1210180071	P	3	3	0.75 mm ²	PUR - BLEND	Black	6.5±0.2	BN, BU, GN/YE
1210180152	P	3	4	0.75 mm ²	PUR - BLEND	Black	7.0±0.2	BN, BU, BK, GN/YE
1210180384	R	3	3	0.75 mm ²	TPR HAL. FREE	Black	6.5±0.2	BN, BU, GN/YE
1210180094	T	3	3	0.75 mm ²	PUR CSA/UL 20668	Yellow	6.5±0.2	BN, BU, GN/YE
1210180309	Y	3	3	0.75 mm ²	SILICONE RUBBER	Red	6.5±0.2	BN, BU, GN/YE
1210180081	F	4	3	1 mm ²	PVC CNOMO	Grey	7.1+0.2/-0	BK1, BK2, GN/YE
1210180042	I	4	2	1 mm ²	PVC CEI 2022 II O.R.	Grey	7.1+0.2/-0	BN, BU
1210180079	I	4	3	1 mm ²	PVC CEI 2022 II O.R.	Grey	7.1+0.2/-0	BN, BU, GN/YE
1210180036	N	4	2	1 mm ²	PVC H05VV-F	Black	6.5±0.2	BN, BU
1210180082	N	4	3	1 mm ²	PVC H05VV-F	Black	6.9±0.2	BN, BU, GN/YE
1210180117	R	4	3	1 mm ²	TPR HAL. FREE	Black	7.1±0.2	BN, BU, GN/YE
1210180085	N	5	3	1.5 mm ²	PVC H05VV-F	Black	7.9±0.2	BN, BU, GN/YE
1210180313	I	6	2	0.35 mm ²	PVC CEI 2011	Grey	4.8±0.2	BN, WH
1210180149	I	9	4	0.75 mm ²	PVC CEI 2022 II	Grey	7.3±0.2	BN, BU, BK, GN/YE

CABLE LIST

CODE	CABLE TYPE	FEATURES	CABLE TYPE CROSS SECTION
N	PVC	APPLICATION GENERAL PURPOSE CABLE WHICH HAS GOOD RESISTANCE TO WATER, BUT USUALLY POOR OIL RESISTANCE	N2=0.5mm ² N3=0.75mm ² N4=1mm ²
I	CEI	APPROVED TO IEC 332-2A, FLAME RETARDANT AND SELF EXTINGUISHING LIMITED RESISTANT TO MINERAL OILS	I2=0.5mm ² I3=0.75mm ² I4=1mm ²
P	PUR	OFFER GOOD RESISTANCE TO OIL AND CHEMICALS, CAN SWELL WHEN CONSTANTLY IMMERSSED IN WATER	P2=0.5mm ² P3=0.75mm ² P4=1mm ²
A	PVC CSA-UL	APPROVED TO CSA-UL 2661, APPLICATION GENERAL PURPOSE CABLE WHICH HAS GOOD RESISTANCE TO WATER, BUT USUALLY POOR OIL RESISTANCE	A2=20 AWG A3=18 AWG
B	PUR CSA-UL	APPROVED TO CSA-UL 20668, VERY GOOD RESISTANCE TO OIL AND CHEMICALS	B2=20 AWG B3=18 AWG

PART LIST

MOLEX P/N	ENGINEERING No.	L (mm)
1210560001	EJT1P3N150C4H	1500
1210560002	EJT1P3N200C4H	2000
1210560003	EJT1P3N500C4H	5000
1210560004	EJT1P3N300C4H	3000
1210560028	EJT1B3A100C42	1000
1210560031	EJT1B3A150C42	1500
1210560037	EJT1P3N050C32	500
1210560042	EJT1P2N150C4H	1500
1210560054	EJT1B2N300C42	3000
1210560055	EJT1B2N300C41	3000
1210560060	EJT1B3N100A1H	1000
1210560061	EJT1B2N10KC42	10000
1210560078	EJT1N3N10KC41	10000
1210560097	EJT1B3A200C41	2000
1210560101	EJT1B3A150C41	1500
1210560205	EJT1B3A10KC42	10000
1210560223	EJT1B3A300C42	3000
1210560225	EJT1P3N600C3G	6000
1210560239	EJT1P3N750C3H	7500
1210560240	EJT1P3N250C3H	2500
1210560241	EJT1P3N500C3H	5000
1210560242	EJT1P3N10KC3H	10000
1210560243	EJT1P3N15KC3H	15000
1210560244	EJT1B3A300C41	3000
1210560246	EJT1P3N200C42	2000
1210560247	EJT1P3N500C42	5000
1210560248	EJT1B2N150C32	1500

Over	Up to and Including	Tolerance
0	1000	±20
1000	3000	±30
3000	5000	±40
5000	10000	±50
10000	15000	±100
15000	20000	±150
20000		±L/100

SYMBOLS ▽ = 0 ▽ = 0 ▽ = 0 ▽ = 0 ▽ = 0 ▽ = 0 ▽ = 0 ▽ = 0 ▽ = 0 ▽ = 0										THIS DRAWING CONTAINS INFORMATION THAT IS PROPRIETARY TO MOLEX ELECTRONIC TECHNOLOGIES, LLC AND SHOULD NOT BE USED WITHOUT WRITTEN PERMISSION DIMENSION UNITS: mm SCALE: 1:1 GENERAL TOLERANCES (UNLESS SPECIFIED): ANGULAR TOL ± 1.0° 4 PLACES ± 3 PLACES ± 2 PLACES ± 0.05 1 PLACE ± 0.3 0 PLACES ± 0.5 DRAFT WHERE APPLICABLE MUST REMAIN WITHIN DIMENSIONS										CURRENT REV DESC: MIGRATED TO ECTR EC NO: 630391 DRWN: SSM 2019/06/13 CHK'D: RSILLER 2020/01/13 APPR: RSILLER 2020/01/13 INITIAL REVISION: DRWN: JMARSZALEK 2013/06/10 APPR: MIWASIECZKO 2014/05/08										 JUNIOR TIMER CONNECTORS EJT1XXXXXXX PRODUCT CUSTOMER DRAWING DOCUMENT NUMBER: SD-121056-002 DOC TYPE: PSD DOC PART: 001 REVISION: A1 MATERIAL NUMBER: SEE PART LIST CUSTOMER: GENERAL MARKET SHEET NUMBER: 2 OF 2									
---	--	--	--	--	--	--	--	--	--	---	--	--	--	--	--	--	--	--	--	--	--	--	--	--	--	--	--	--	--	---	--	--	--	--	--	--	--	--	--

TABELA 2 KABLE / TABLE 2 CABLES

Molex PN Raw cable	Cable type	Cable code	Wires no.	Cross Section	Jacket material	Jacket color	Diameter Ø [mm]	Wire colors
1202091424	I	0	3	1 mm ²	PVC CEI 2022 II O.R.	Grey	7.6±0.2	BN, BU, GN/YE
1210180467	A	2	2	20 AWG	PVC CSA/UL 2661	Black	5.4±0.2	BN, BU
1210180128	A	2	3	20 AWG	PVC CSA/UL 2661	Black	5.6±0.2	BN, BU, GN/YE
1210180394	A	2	4	20 AWG	PVC CSA/UL 2661	Black	6.2±0.25	BN, BU, BK, GN/YE
1210180297	B	2	2	20 AWG	PUR CSA/UL 20668	Black	5.6±0.2	BN, BU
1210180126	B	2	3	20 AWG	PUR CSA/UL 20668	Black	5.6±0.2	BN, BU, GN/YE
1210180387	B	2	4	20 AWG	PUR CSA/UL 20668	Black	6.3±0.2	BN, BU, BK, GN/YE
1210180284	D	2	3	0.5 mm ²	PVC CEI 20-20	Grey	5.5+0.3/-0	BN, BU, GN/YE
1210180047	I	2	2	0.5 mm ²	PVC CEI 2022 II O.R.	Grey	5.5+0.3/-0	BN, BU
1210180284	I	2	3	0.5 mm ²	PVC CEI 2022 II O.R.	Grey	5.5+0.3/-0	BN, BU, GN/YE
1210180146	I	2	4	0.5 mm ²	PVC CEI 2022 II O.R.	Grey	6.5±0.2	BN, BU, BK, GN/YE
1210180177	I	2	5	0.5 mm ²	PVC CEI 2022 II O.R.	Grey	7.0 +0.3/-0	BN, BU, BK, WH, GN/YE
1210180022	N	2	2	0.5 mm ²	PVC H03VV-F	Black	5.2±0.2	BN, BU
1202092753	N	2	3	0.5 mm ²	PVC H03VV-F	Black	5.5±0.2	BN, BU, GN/YE
1210180153	N	2	4	0.5 mm ²	PVC H03VV-F	Black	5.9±0.3	BN, BU, BK, GN/YE
1210180046	P	2	2	0.5 mm ²	PUR - BLEND	Black	5.5±0.2	BN, BU
1202092439	P	2	3	0.5 mm ²	PUR - BLEND	Black	5.5 +0.3/-0	BN, BU, GN/YE
1210180302	P	2	4	0.5 mm ²	PUR - BLEND	Black	6.5±0.2	BN, BU, BK, GN/YE
1202092215	P	2	5	0.5 mm ²	PUR - BLEND	Black	7+0.3/-0.1	BN, BU, BK, WH, GN/YE
1210180409	A	3	2	18 AWG	PVC CSA/UL 2661	Black	6.2±0.25	BN, BU
1210180129	A	3	3	18 AWG	PVC CSA/UL 2661	Black	6.5±0.25	BN, BU, GN/YE
1210180159	A	3	4	18 AWG	PVC CSA/UL 2661	Black	7.0+0.3/-0	BN, BU, BK, GN/YE
1210180484	A	3	5	18 AWG	PVC CSA/UL 2661	Black	7.8±0.25	BN, BU, BK, WH, GN/YE
1210180351	B	3	2	18 AWG	PUR CSA/UL 20668	Black	6.2±0.2	BN, BU
1210180127	B	3	3	18 AWG	PUR CSA/UL 20668	Black	6.5±0.2	BN, BU, GN/YE
1210180160	B	3	4	18 AWG	PUR CSA/UL 20668	Black	7±0.2	BN, BU, BK, GN/YE
1210180463	B	3	5	18 AWG	PUR CSA/UL 20668	Black	7.8±0.25	BN, BU, BK, WH, GN/YE
1210180073	D	3	3	0.75 mm ²	PVC CEI 20-20	Grey	6.5±0.2	BN, BU, GN/YE
1210180145	D	3	4	0.75 mm ²	PVC CEI 20-20	Grey	7.1±0.2	BN, BU, BK, GN/YE
1202098206	I	3	2	0.75 mm ²	PVC CEI 2022 II O.R.	Grey	5.5±0.2	BK1, BK2
1210180120	I	3	3	0.75 mm ²	PVC CEI 2022 II O.R.	Grey	6.0±0.2	BK1, BK2, BK3
1210180143	I	3	4	0.75 mm ²	PVC CEI 2022 II O.R.	Grey	7.0±0.2	BN, BU, BK, GN/YE
1210180032	N	3	2	0.75 mm ²	PVC H05VV-F	Black	6.2±0.2	BN, BU
1210180069	N	3	3	0.75 mm ²	PVC H05VV-F	Black	6.5±0.2	BN, BU, GN/YE
1210180144	N	3	4	0.75 mm ²	PVC H05VV-F	Black	7.1±0.2	BN, BU, BK, GN/YE
1210180174	N	3	5	0.75 mm ²	PVC H05VV-F	Black	8.0+0.2/-0	BN, BU, BK, GY, GN/YE
1202094190	P	3	2	0.75 mm ²	PUR - BLEND	Black	6.5±0.2	BN, BU
1210180071	P	3	3	0.75 mm ²	PUR - BLEND	Black	6.5±0.2	BN, BU, GN/YE
1210180152	P	3	4	0.75 mm ²	PUR - BLEND	Black	7.0±0.2	BN, BU, BK, GN/YE

TABELA 2 KABLE / TABLE 2 CABLES

Molex PN Raw cable	Cable type	Cable code	Wires no.	Cross Section	Jacket material	Jacket color	Diameter Ø [mm]	Wire colors
1210180384	R	3	3	0.75 mm ²	TPR HAL. FREE	Black	6.5±0.2	BN, BU, GN/YE
1210180094	T	3	3	0.75 mm ²	PUR CSA/UL 20668	Yellow	6.5±0.2	BN, BU, GN/YE
1210180309	Y	3	3	0.75 mm ²	SILICONE RUBBER	Red	6.5±0.2	BN, BU, GN/YE
1210180081	F	4	3	1 mm ²	PVC CNOMO	Grey	7.1+0.2/-0	BK1, BK2, GN/YE
1210180042	I	4	2	1 mm ²	PVC CEI 2022 II O.R.	Grey	7.1+0.2/-0	BN, BU
1210180079	I	4	3	1 mm ²	PVC CEI 2022 II O.R.	Grey	7.1+0.2/-0	BN, BU, GN/YE
1210180036	N	4	2	1 mm ²	PVC H05VV-F	Black	6.5±0.2	BN, BU
1210180082	N	4	3	1 mm ²	PVC H05VV-F	Black	6.9±0.2	BN, BU, GN/YE
1210180117	R	4	3	1 mm ²	TPR HAL. FREE	Black	7.1±0.2	BN, BU, GN/YE
1210180085	N	5	3	1.5 mm ²	PVC H05VV-F	Black	7.9±0.2	BN, BU, GN/YE
1210180313	I	6	2	0.35 mm ²	PVC CEI 2011	Grey	4.8±0.2	BN, WH
1210180148	I	9	4	0.75 mm ²	PVC CEI 2022 II	Grey	7.3±0.2	BN, BU, BK, GN/YE

TABLE 1 - CABLES TYPE

Code	Cable types	Features	Cross Section
N	PVC	Application general purpose cable which has good resistance to water, but usually poor oil resistance.	0.5 mm ² 0.75 mm ² 1 mm ²
I	CEI	Approved to IEC 332-2A, flame retardant and self extinguishing. Limited resistant to mineral oils.	0.5 mm ² 0.75 mm ² 1 mm ²
P	PUR	Offer good resistance to oil and chemicals. Can swell when constantly immersed in water.	0.5 mm ² 0.75 mm ² 1 mm ²
A	PVC CSA-UL	Approved to CSA-UL 2661, application general purpose cable which has good resistance to water, but usually poor oil resistance.	20 AWG 18 AWG
B	PUR CSA-UL	Approved to CSA-UL 20668, very good resistance to oil and chemicals.	20 AWG 18 AWG

ORIGINAL RELEASE EC NO: IPG2014-1897 DRWN: JMARSZALEK 2013/06/11 CHKD: DSTACHOWIAK 2014/05/07 APPR: MIWASIECZKO 2014/05/08	QUALITY SYMBOLS	GENERAL TOLERANCES (UNLESS SPECIFIED)	DIMENSION STYLE	SCALE	DESIGN UNITS	THIRD ANGLE PROJECTION
	▼ = 0 ◻ = 0	mm INCH 4 PLACES ± --- ± --- 3 PLACES ± --- ± --- 2 PLACES ± --- ± --- 1 PLACE ± --- ± --- 0 PLACE ± --- ± ---	MM ONLY	-	METRIC	
	DESCRIPTION	DRAWN BY: JMARSZALEK DATE: 2013/06/11 CHECKED BY: DSTACHOWIAK DATE: 2014/05/07 APPROVED BY: MIWASIECZKO DATE: 2014/05/08	TITLE	JUNIOR TIMER CONNECTORS EJT1XXXXXXXXXX		
	REV	ANGULAR ± --- ° DRAFT WHERE APPLICABLE MUST REMAIN WITHIN DIMENSIONS	MATERIAL NO. MATRIX DRAWING	DOCUMENT NO. SD-121056-002	SHEET NO. 2 OF 2	