

# SUGGESTED MATING TAB

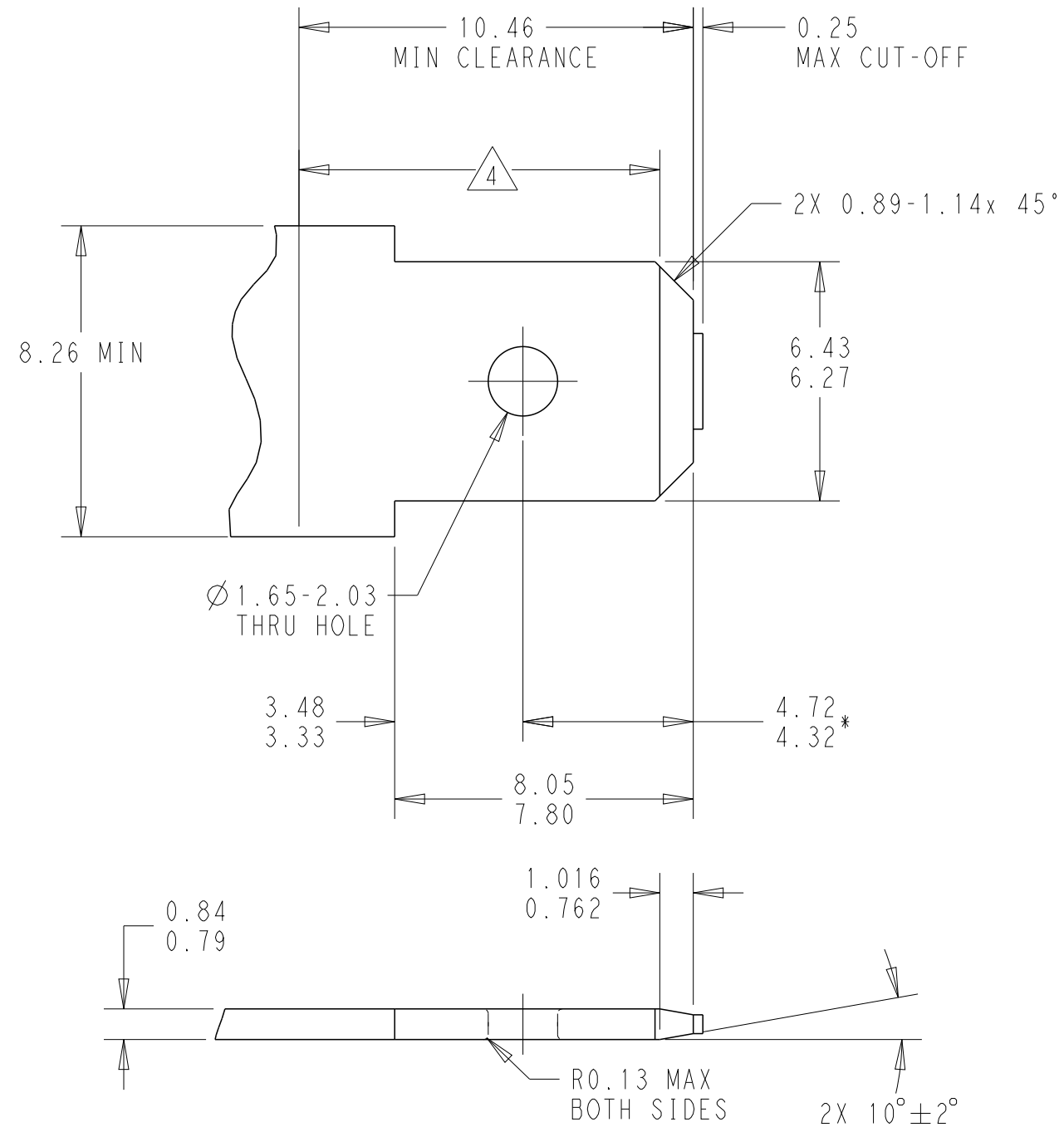

1. MATERIAL: 1/2 HARD BRASS OR NICKEL PLATED STEEL
  2. NO BURRS PERMISSIBLE AROUND HOLE
  3. TIN PLATING IS REQUIRED ON BRASS WHEN TERMINAL TEMPERATURE IS OVER 225°F
  4. MUST BE FLAT WITHIN 0.08 OVER THIS LENGTH
  5. HOLE MUST BE SYMMETRICAL ABOUT TAB  $\perp$  WITHIN 0.08.
- \* TO BE USED ONLY WHEN SHOULDER IS ELIMINATED.

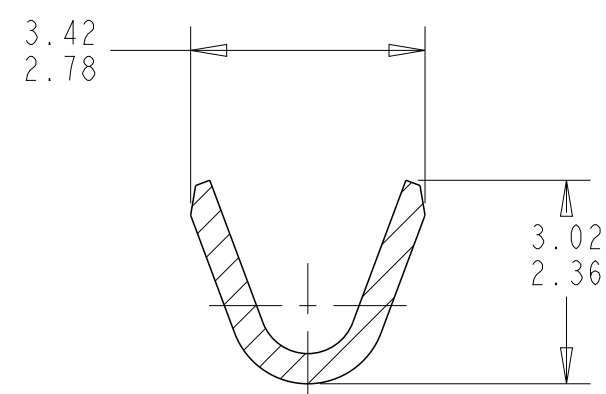

SECTION N-N  
SCALE 10:1

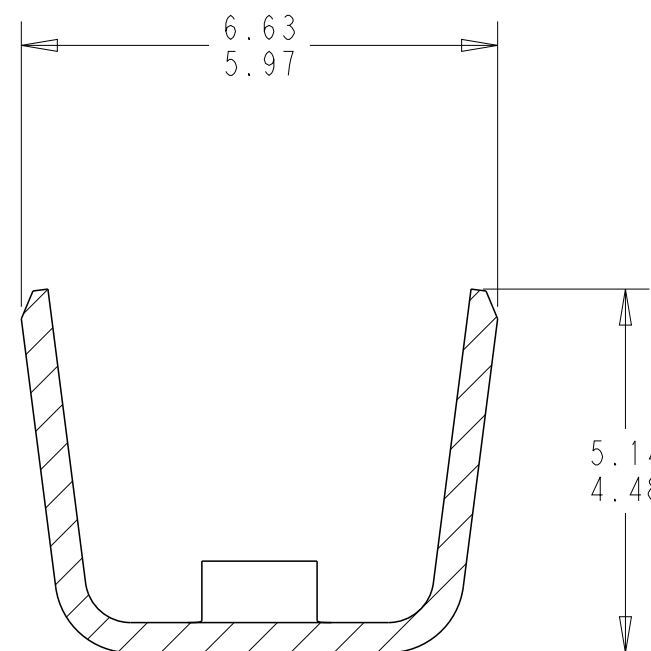

SECTION P-P  
SCALE 10:1

REVISIONS					
P	LTR	DESCRIPTION	DATE	DWN	APVD
A		REVISED PER ECN-21-111598	04AUG2021	BDA	KR
A1		REVISED PER ECN-22-173509	07SEP2022	TDB	KR
B		REVISED PER ECN-23-193388	12JAN2023	TDB	KR

1. CONTINUOUS STRIP ON REELS, BREAKS MAY BE PRESENT
2. THIS DIMENSION MUST BE MAINTAINED FOR PROPER FUNCTION OF THE LATCHING MECHANISM.
3. WIRE RANGE:  
 (2) 20 AWG STRANDED / (2) 2.56 INSULATION DIAMETER DOUBLE WIRE  
 (2) 22 AWG STRANDED / (2) 2.38 INSULATION DIAMETER DOUBLE WIRE
4. THIS TERMINAL MUST BE USED WITH A TIN PLATED TAB

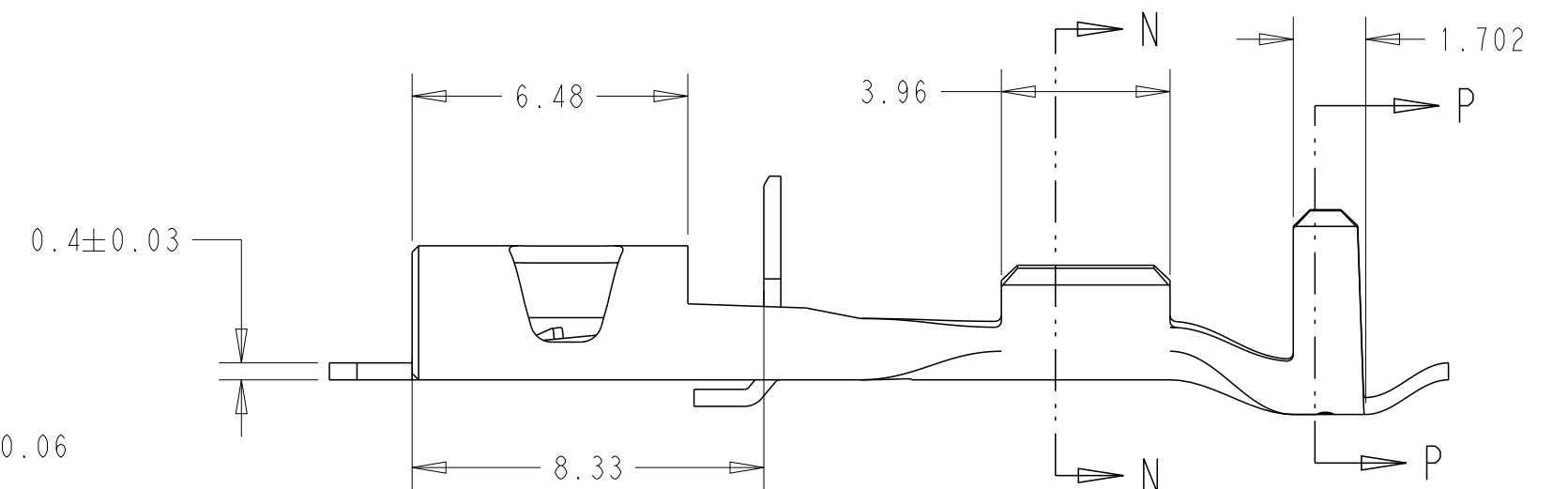
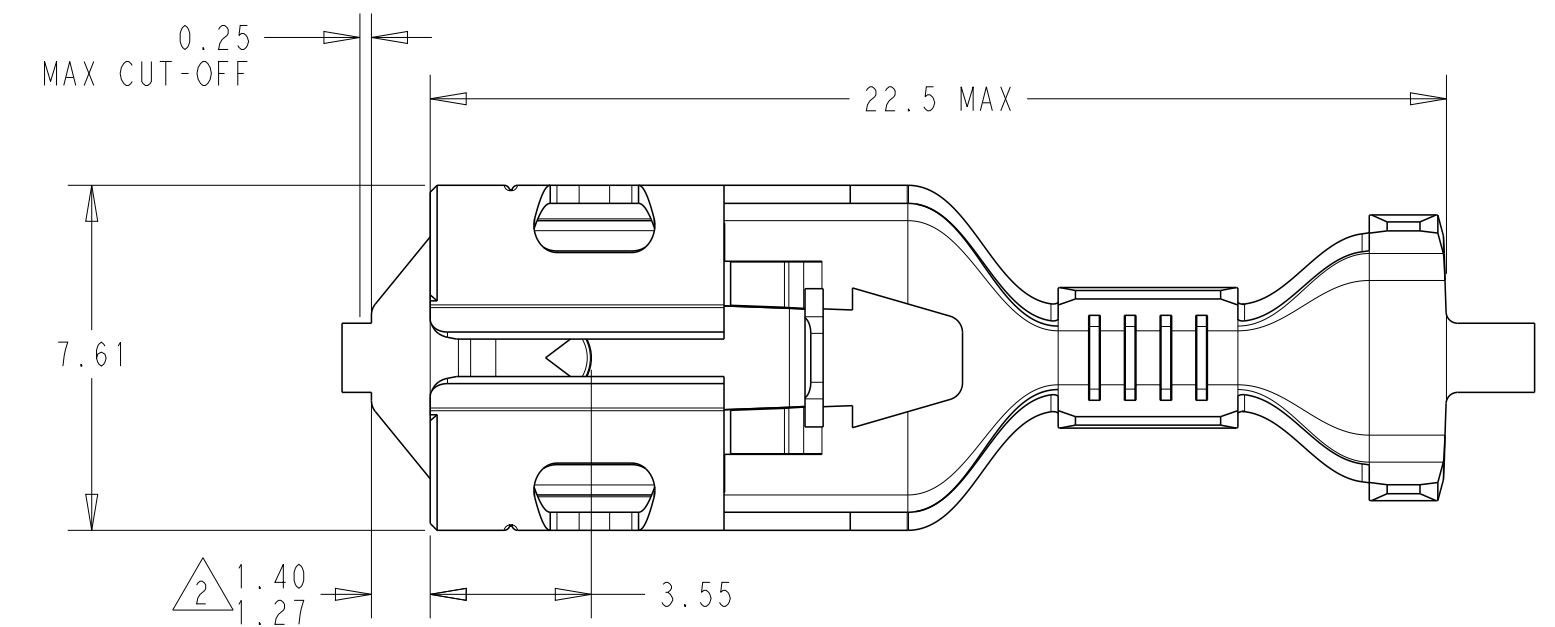

UNPLATED 4	BRASS	2238283-1
FINISH	MATERIAL	PART NUMBER

THIS DRAWING IS A CONTROLLED DOCUMENT.		DWN B. WEAVER 05 JUN 2020	TE Connectivity	
DIMENSIONS: mm		CHK K. RANDOLPH 05 JUN 2020		
TOLERANCES UNLESS OTHERWISE SPECIFIED:		APVD W. MOYER 05 JUN 2020	NAME RECEPTACLE, POSITIVE-LOCK 250 SERIES	
0 PLC ± 1 PLC ± 2 PLC ±0.25 3 PLC ± 4 PLC ± ANGLES ±		PRODUCT SPEC -	APPLICATION SPEC 114-2074	
MATERIAL SEE TABLE		WEIGHT -	SIZE A2	CAGE CODE 00779
FINISH SEE TABLE		CUSTOMER DRAWING	DRAWING NO C-2238283	RESTRICTED TO -
SCALE 6:1			SHEET 1 OF 1	REV B