

GENERAL DESCRIPTION

The XRP431L is a three-terminal adjustable shunt voltage regulator providing a highly accurate bandgap reference.

The XRP431L acts as an open-loop error amplifier with a 1.24V temperature compensation reference. The XRP431L has thermal stability, wide operating current of 100mA and broad temperature range of -40°C to 125°C, making it suitable for a variety of applications which require a low-cost, high performance solution. The XRP431L tolerance of 0.5% is proven to be sufficient to overcome all other errors in the system to virtually eliminate the need for trimming in the power supply manufacturer's assembly line and contribute a significant cost savings. The output voltage may be adjusted to any value between V_{REF} and 18 volts with two external resistors.

The XRP431L is available in RoHS compliant, "green"/halogen free 5-pin SOT23 package.

APPLICATIONS

- **Charger**
- **Switching Power Supplies**
- **Graphic Cards**
- **Monitors, VCRs, TVs**

FEATURES

- **0.5% Precise Output Voltage**
 - Adjustable 1.24V to 18V
- **Wide Operating Current**
 - 0.1mA to 100mA
- **Low Temperature Coefficient at 20ppm/°C**
- **Extended Temperature Range**
 - -40°C to +125°C
- **RoHS Compliant "Green"/Halogen Free 5-pin SOT23 Package**

TYPICAL APPLICATION DIAGRAM

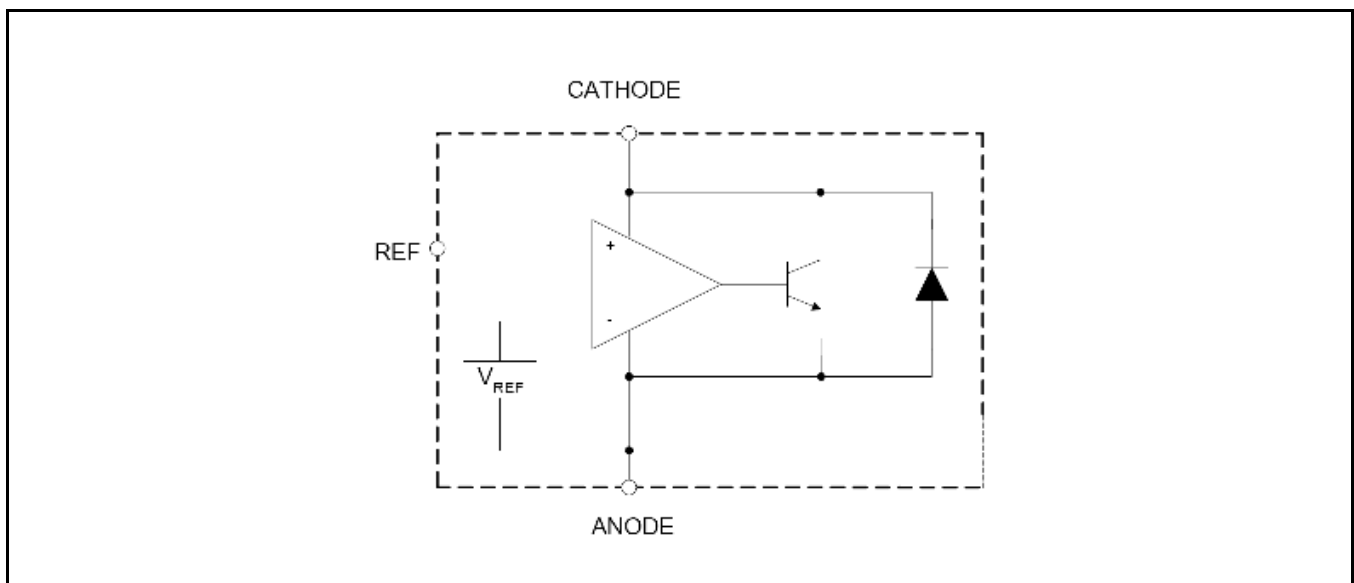

Fig. 1: XRP431L Application Diagram



ABSOLUTE MAXIMUM RATINGS

These are stress ratings only and functional operation of the device at these ratings or any other above those indicated in the operation sections of the specifications below is not implied. Exposure to absolute maximum rating conditions for extended periods of time may affect reliability.

Cathode-Anode Voltage V_{KA} 20V
 Operating Cathode Current (cont.) I_{KA} 100mA
 Reference Input Current Range I_{REF} 10mA
 Power Dissipation (Cont. 25°C) P_D 770mW
 Junction Temperature 150°C
 Storage Temperature T_{STG} -65°C to 150°C
 ESD Rating (HBM - Human Body Model) 2kV

OPERATING RATINGS

Cathode-Anode Voltage V_{KA} <18V
 Operating Cathode Current (cont.) I_{KA} <100mA
 Ambient Temperature Range -40°C to 125°C
 Thermal Resistance θ_{JC} (SOT23-5) 84.8°C/W

ELECTRICAL SPECIFICATIONS

Specifications with standard type are for an Operating Ambient Temperature of $T_A = 25^\circ\text{C}$ only; limits applying over the full Operating Ambient Temperature range are denoted by a "•". Minimum and Maximum limits are guaranteed through test, design, or statistical correlation. Typical values represent the most likely parametric norm at $T_A = 25^\circ\text{C}$, and are provided for reference purposes only.

Parameter	Min.	Typ.	Max.	Units	Conditions
Reference Voltage	1.234	1.240	1.246	V	Test circuit 1 $V_{KA}=V_{REF}, I_{KA}=10\text{mA}$
ΔV_{REF} with temperature T_C		2	10	mV	Test circuit 1 $V_{KA}=V_{REF}, I_{KA}=10\text{mA}, 0^\circ\text{C} \leq T_A \leq 70^\circ\text{C}$
		3	10	mV	Test circuit 1 $V_{KA}=V_{REF}, I_{KA}=10\text{mA}, -40^\circ\text{C} \leq T_A \leq 85^\circ\text{C}$
		4	15	mV	• Test circuit 1 $V_{KA}=V_{REF}, I_{KA}=10\text{mA}, -40^\circ\text{C} \leq T_A \leq 125^\circ\text{C}$
Ratio of change in V_{REF} to Cathode Voltage $\Delta V_{REF} / \Delta V_{KA}$	-1.5	-0.5		mV/V	Test circuit 2 $V_{REF} \leq \Delta V_{KA} \leq 16\text{V}, I_{KA}=10\text{mA}$
Reference Input Current I_{REF}		0.15	0.4	μA	Test circuit 2 $I_{KA}=10\text{mA}, R1=10\text{k}\Omega, R2=\infty$
I_{REF} Temperature Deviation ΔI_{REF}		0.1	0.4	μA	• Test circuit 2 $I_{KA}=10\text{mA}, R1=10\text{k}\Omega, R2=\infty$
Minimum I_{KA} for Regulation $I_{KA(MIN)}$		55	80	μA	Test circuit 1 $V_{KA}=V_{REF}$
Off State Leakage $I_{KA(OFF)}$		40	100	nA	Test circuit 3 $V_{KA}=18\text{V}, V_{REF}=0\text{V}$
		10	50	nA	Test circuit 3 $V_{KA}=6\text{V}, V_{REF}=0\text{V}$
Dynamic Output Impedance Z_{KA}		0.05	0.15	Ω	Test circuit 1 $V_{KA}=V_{REF}, f_Z \leq 1\text{KHz}, I_{KA}=1 \text{ to } 100\text{mA}$

BLOCK DIAGRAM

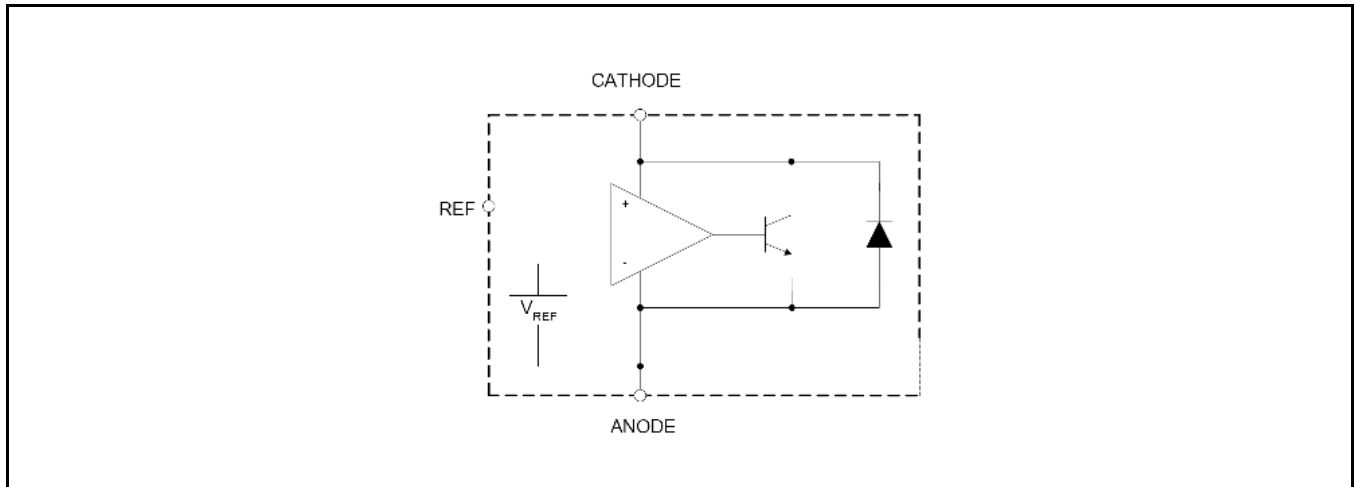

Fig. 2: XRP431L Block Diagram

PIN ASSIGNMENT

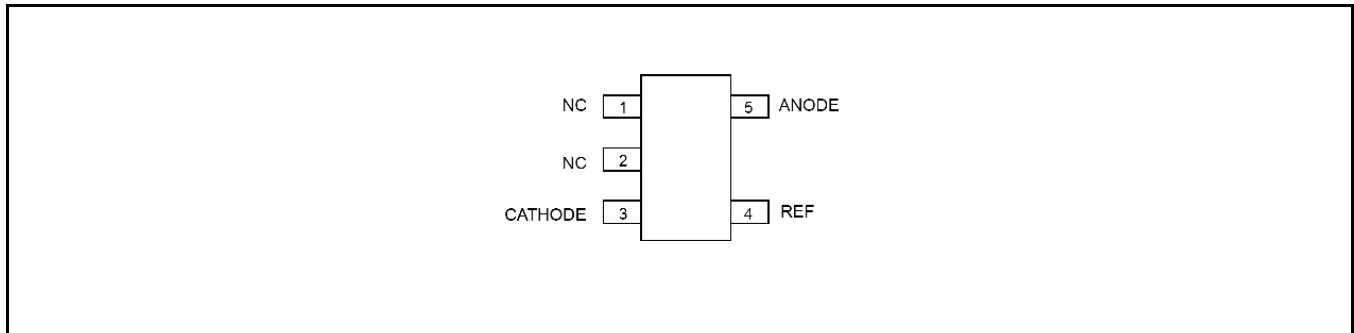

Fig. 3: XRP431L Pin Assignment

ORDERING INFORMATION

Part Number	Temperature Range	Marking	Package	Packing Quantity	Note 1	Note 2
XRP431LES5TRR3-F	-40°C ≤ T _A ≤ +125°C	GCWW	5-pin SOT23	3K/Tape & Reel	RoHS Compliant Halogen free	

“WW” = Work Week

Note that the XRP431L series is packaged in Tape and Reel with a reverse part orientation as per the following diagram

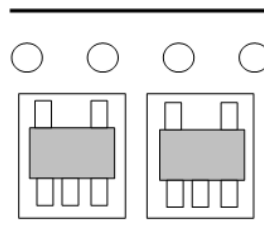

TYPICAL PERFORMANCE CHARACTERISTICS

All data taken at $T_A = 25^\circ\text{C}$, unless otherwise specified - Schematic and BOM from Application Information section of this datasheet.

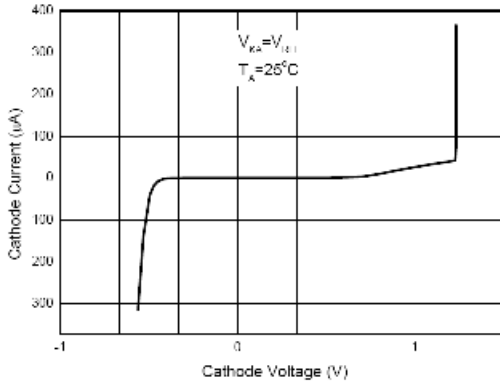

Fig. 4: Cathode Current vs Cathode Voltage

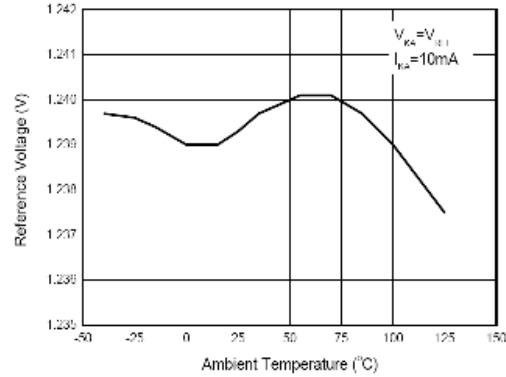

Fig. 5: Reference Voltage vs Ambient Temperature

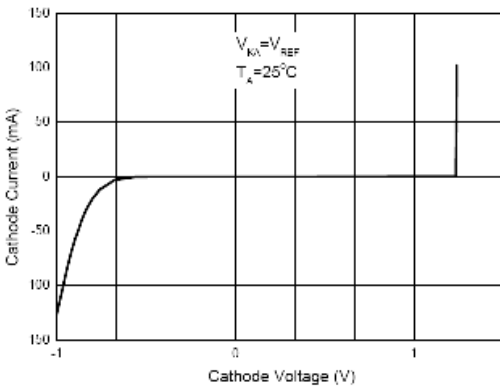

Fig. 6: Low Current Operating Characteristics

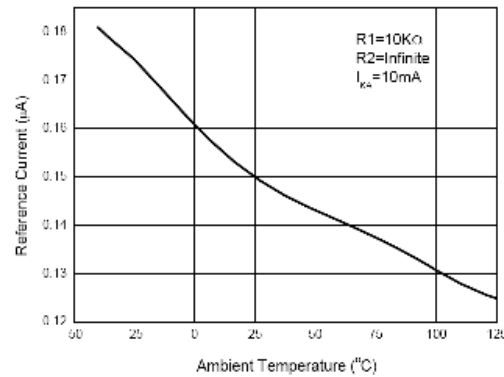

Fig. 7: Reference Input Current vs Ambient Temperature

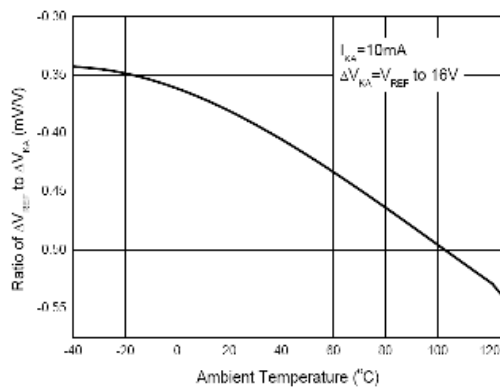

Fig. 8: Δ Reference Voltage to Δ Cathode Voltage Ratio

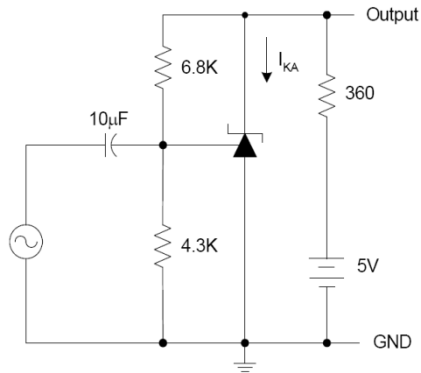

Fig. 9: Test Circuit for Gain vs Frequency Response

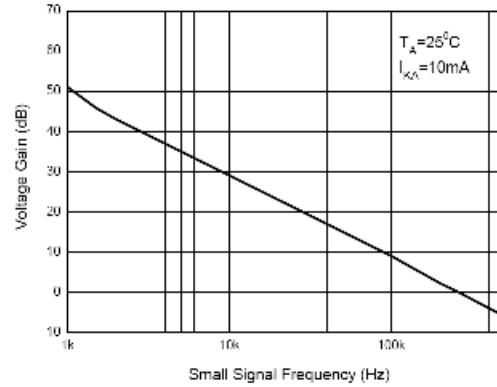

Fig. 10: Small Signal Gain vs Frequency

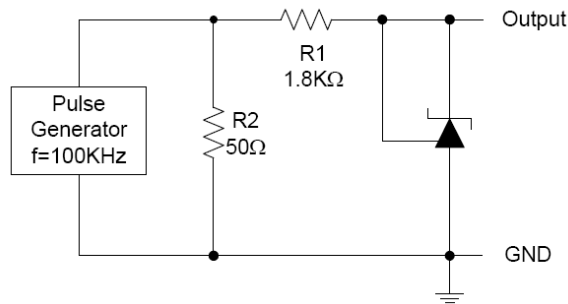

Fig. 11: Test Circuit for Pulse Response

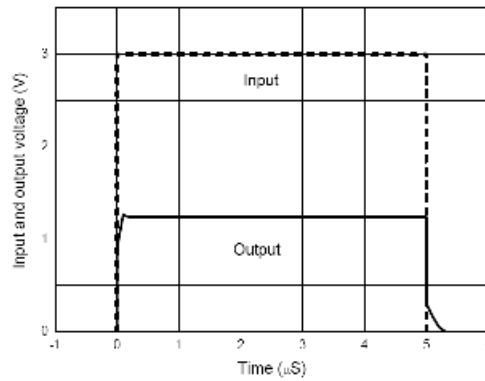

Fig. 12: Pulse Response

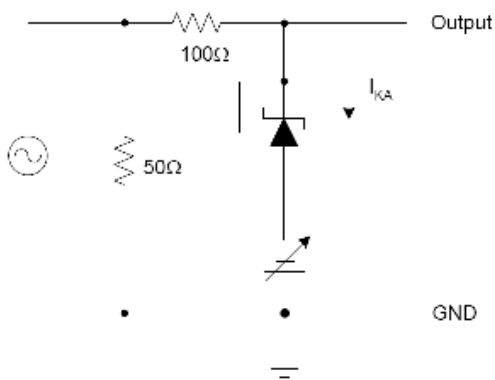

Fig. 13: Test Circuit for Dynamic Output Impedance

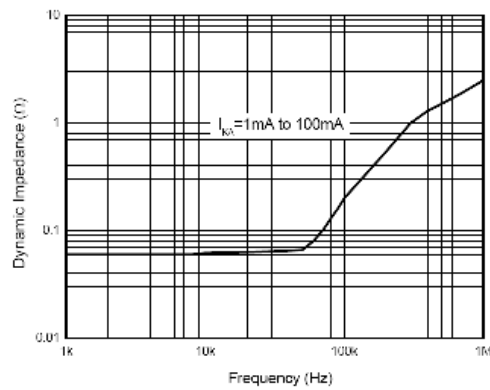
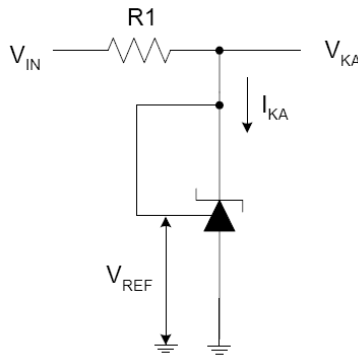

Fig. 14: Dynamic Output Impedance

TEST CIRCUITS

TEST CIRCUIT 1

Test circuit for $V_{KA} = V_{REF}$



TEST CIRCUIT 2

Test circuit for $V_{KA} > V_{REF}$

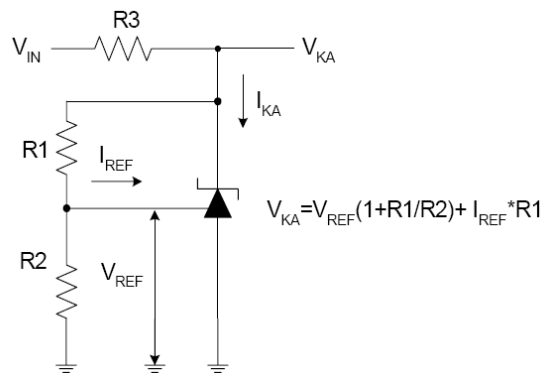

TEST CIRCUIT 3

Test circuit for I_{KOFF}

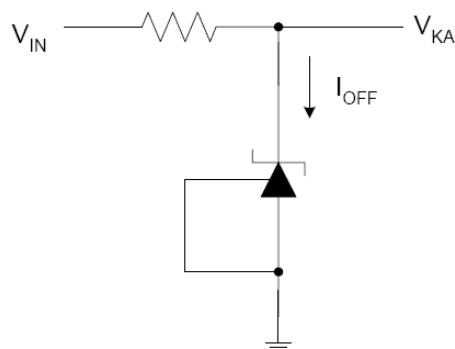

PACKAGE SPECIFICATION

5-PIN SOT23

Unit: mm (inch)

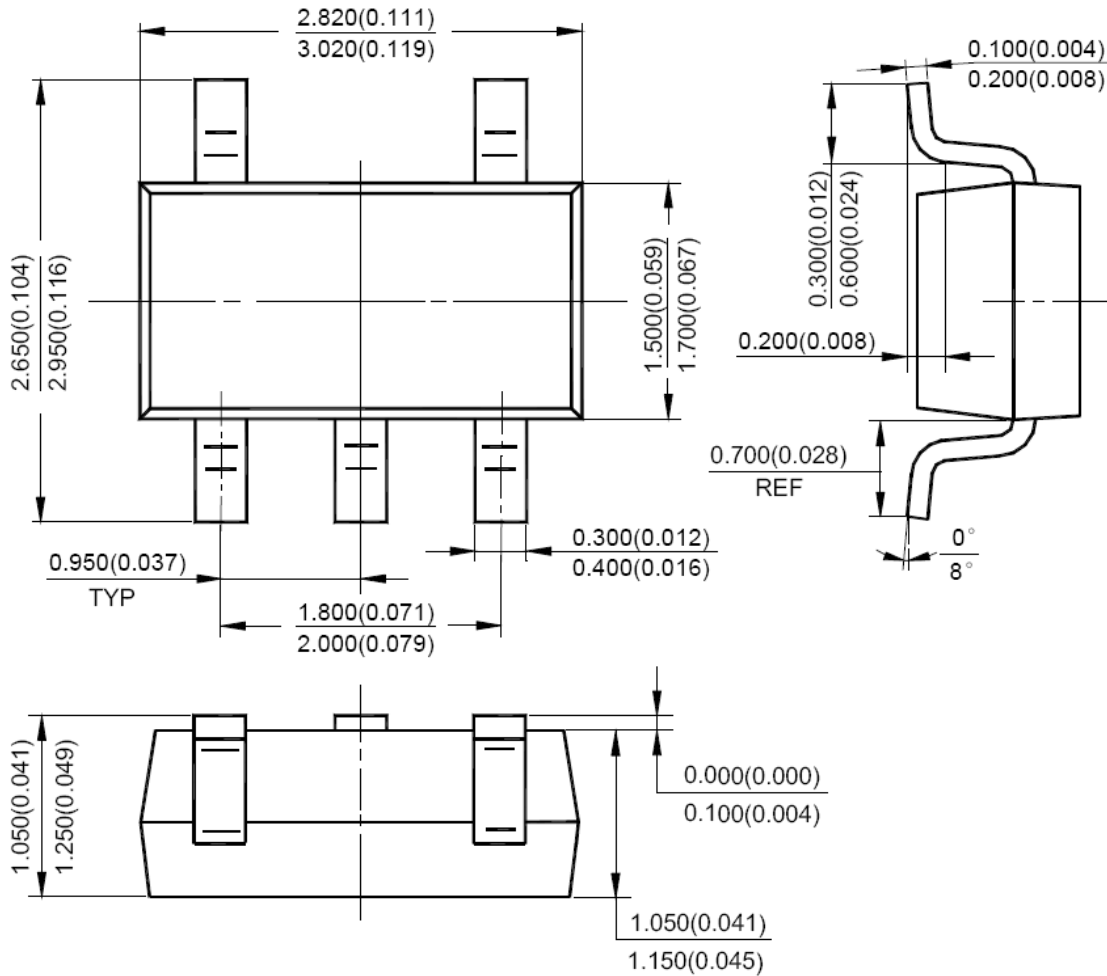



REVISION HISTORY

Revision	Date	Description
1.0.0	10/02/2009	Initial release of datasheet
1.1.0	03/24/2010	Modified part number to reflect RoHS compliant, "green"/halogen free compliance.
1.2.0	09/16/2010	Modified part number to reflect reverse part orientation in tape & reel and 3K/reel.

FOR FURTHER ASSISTANCE

Email: customersupport@exar.com
Exar Technical Documentation: <http://www.exar.com/TechDoc/default.aspx?>

EXAR CORPORATION

HEADQUARTERS AND SALES OFFICES

48720 Kato Road
Fremont, CA 94538 – USA
Tel.: +1 (510) 668-7000
Fax: +1 (510) 668-7030
www.exar.com



NOTICE

EXAR Corporation reserves the right to make changes to the products contained in this publication in order to improve design, performance or reliability. EXAR Corporation assumes no responsibility for the use of any circuits described herein, conveys no license under any patent or other right, and makes no representation that the circuits are free of patent infringement. Charts and schedules contained here in are only for illustration purposes and may vary depending upon a user's specific application. While the information in this publication has been carefully checked; no responsibility, however, is assumed for inaccuracies.

EXAR Corporation does not recommend the use of any of its products in life support applications where the failure or malfunction of the product can reasonably be expected to cause failure of the life support system or to significantly affect its safety or effectiveness. Products are not authorized for use in such applications unless EXAR Corporation receives, in writing, assurances to its satisfaction that: (a) the risk of injury or damage has been minimized; (b) the user assumes all such risks; (c) potential liability of EXAR Corporation is adequately protected under the circumstances.

Reproduction, in part or whole, without the prior written consent of EXAR Corporation is prohibited.