

- 1 USE WITH HAND TOOL: 220190-1
- 2 USE WITH AIR CORE DIELECTRIC ONLY
- 3. CENTER CONTACT CRIMP (HEX): 1.73 [.068]
- 4. SEE I.S. 9370

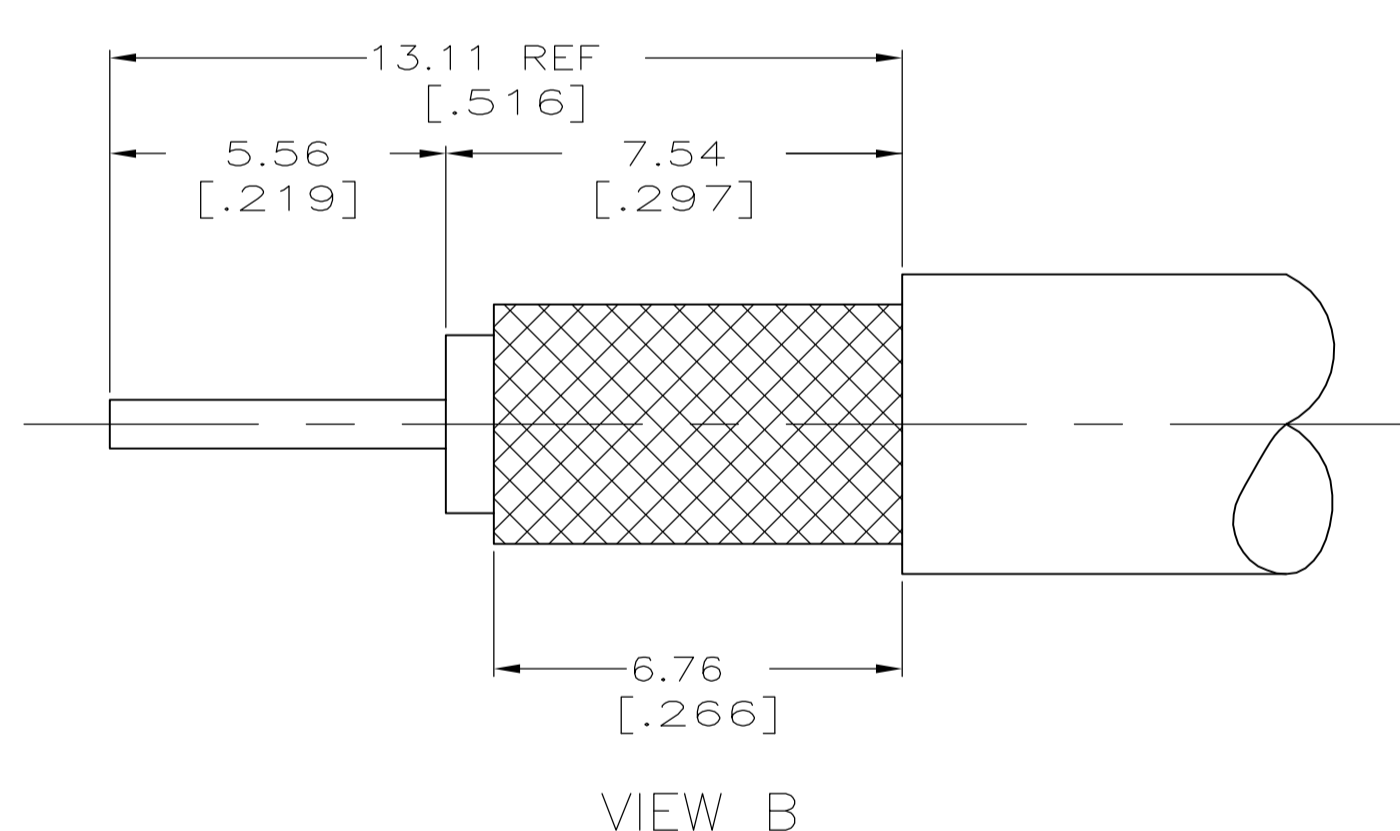
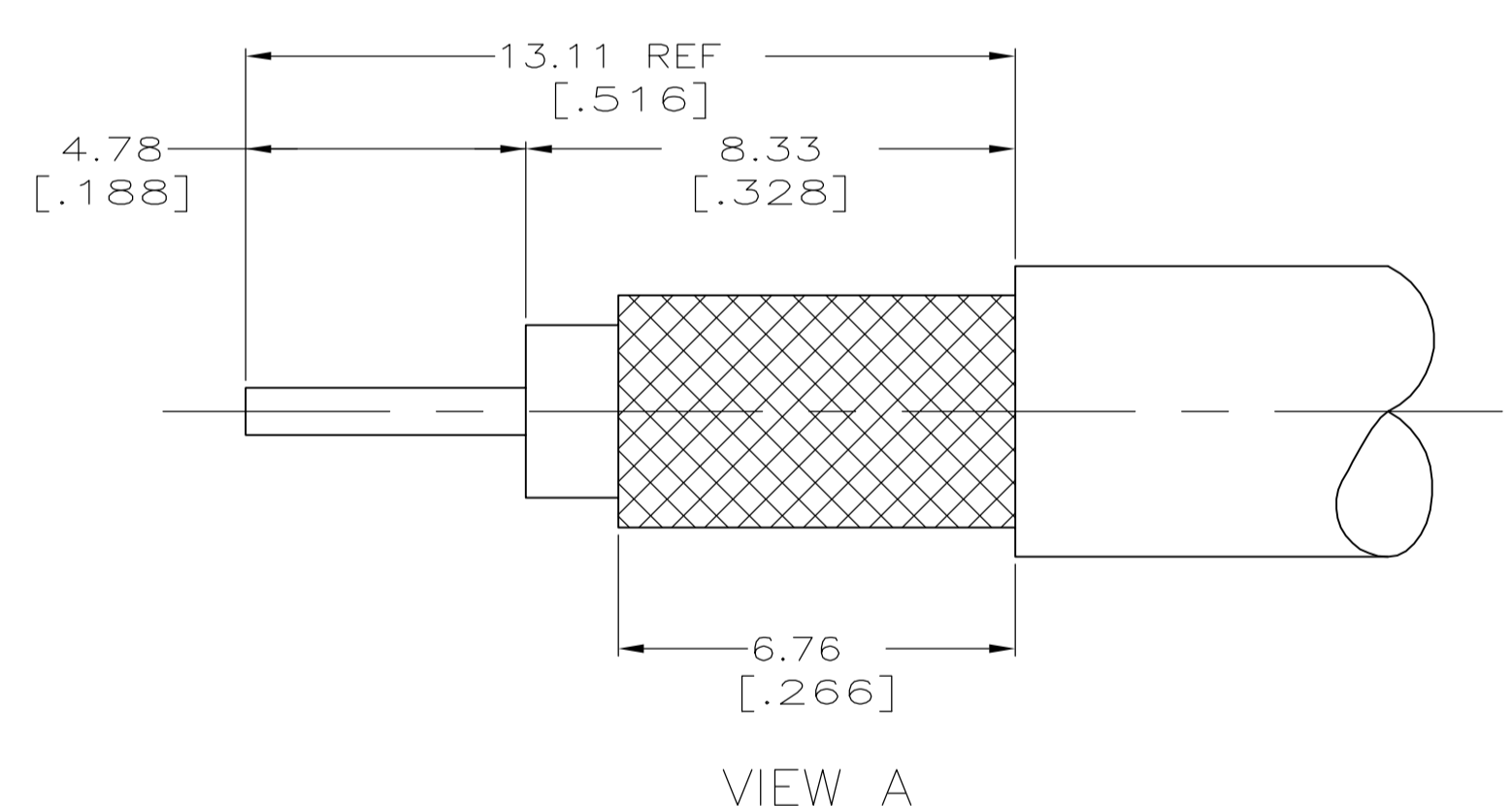

RECOMMENDED STRIP LENGTH

OBSOLETE	RG-174/U, 174A/U, 188/U, 188A/U, 316/U	A	4.52 [.178]	58465-3	227194-1	-	9-413658-0	1-222246-0	222514-3	9-222506-1
OBSOLETE	RG-58/U, 58A/U, 58B/U, 58C/U	A	5.41 [.213]	58465-1	-	-	9-221132-0	222246-2	222514-1	9-222506-0
OBSOLETE	RG-223/U	A	5.41 [.213]	58465-1	-	-	8-221132-9	222246-2	222514-1	1-222506-1
OBSOLETE	RG-188/316 TYPE DOUBLE BRAID	A	4.52 [.178]	58465-3	227194-1	-	9-413658-2	1-222246-0	222514-3	222506-9
OBSOLETE	RG-141/U, 141A/U, BELDEN 9907, 89907	A	5.41 [.213]	58465-1	-	-	9-221132-0	1-222246-6	222514-1	222506-8
OBSOLETE	RG-180/U, 180A/U, 180B/U, 195/U, 195A/U	A	4.52 [.178]	58465-3	-	-	9-413658-1	1-222246-3	222514-3	222506-7
OBSOLETE	RG-179/U, 179A/U, 179B/U, 187/U, 187A/U	A	4.52 [.178]	58465-3	227194-1	-	9-413658-0	1-222246-3	222514-3	222506-6
	RG-174/U, 174A/U, 188/U, 188A/U, 316/U	A	4.52 [.178]	58465-3	227194-1	-	9-413658-0	1-222246-0	222514-3	222506-5
OBSOLETE	RG-142/U, 142A/U, 412B/U, 400/U	A	5.41 [.213]	58465-1	-	-	9-221132-4	1-222246-6	222514-1	222506-4
SUPERSEDED BY 222506-1	RG-58/U, 58A/U, 58B/U, 58C/U	A	5.41 [.213]	58465-1	-	-	9-221132-0	222246-5	222514-1	222506-3
	RG-59/U, 59A/U, 59B/U, 62/U, 62A/U, 62B/U	B	6.48 [.255]	58465-1	-	227423-1	9-221132-1	222246-4	222514-2	222506-2
	RG-58/U, 58A/U, 58B/U, 58C/U	A	5.41 [.213]	58465-1	-	-	9-221132-0	222246-2	222514-1	222506-1

FOR USE WITH CABLE	VIEW	FERRULE CRIMP (HEX)	DIE SET	5 TUBING QTY=1	4 SPACER QTY=1	3 FERRULE QTY=1	2 CONTACT QTY=1	1 PLUG ASSEMBLY QTY=1	PART NUMBER
--------------------	------	---------------------	---------	----------------	----------------	-----------------	-----------------	-----------------------	-------------

THIS DRAWING IS A CONTROLLED DOCUMENT.

DIMENSIONS: mm [INCHES]	TOLERANCES UNLESS OTHERWISE SPECIFIED:	DWN M. E. COWHER 4-26-91	Tyco Electronics Corporation Harrisburg, PA 17105-3608
0 PLC ± -	1 PLC ± -	CHK J. T. LIPPERT 5-17-91	
2 PLC ± 0.41 [.016]	3 PLC ± -	APVD M. PHILLIPS 5-17-91	PRODUCT SPEC 108-12046
4 PLC ± -	ANGLES ± -	MATERIAL -	APPLICATION SPEC -
FINISH -	WEIGHT -	SIZE A1	RESTRICTED TO
CUSTOMER DRAWING	SCALE 8:1	DRAWING NO. 00779	REV K1