

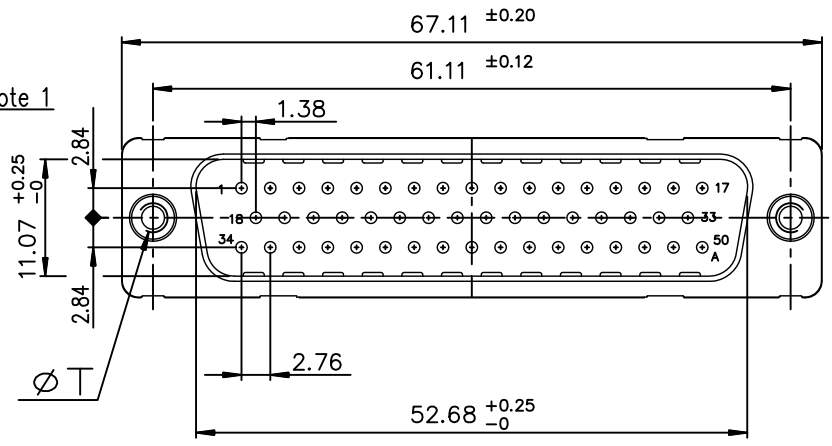

FCconnect.com

Copyright FCJ

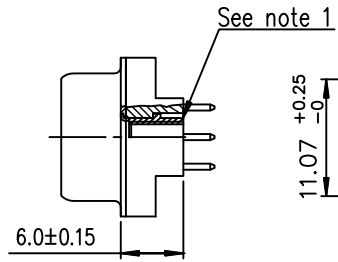
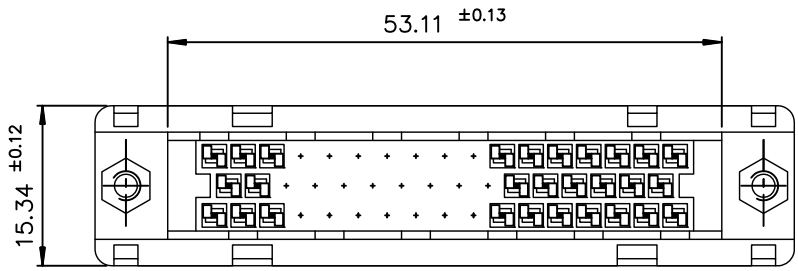

PC card drilling dimensions  
(after plating – thickness: 1.60 mm)

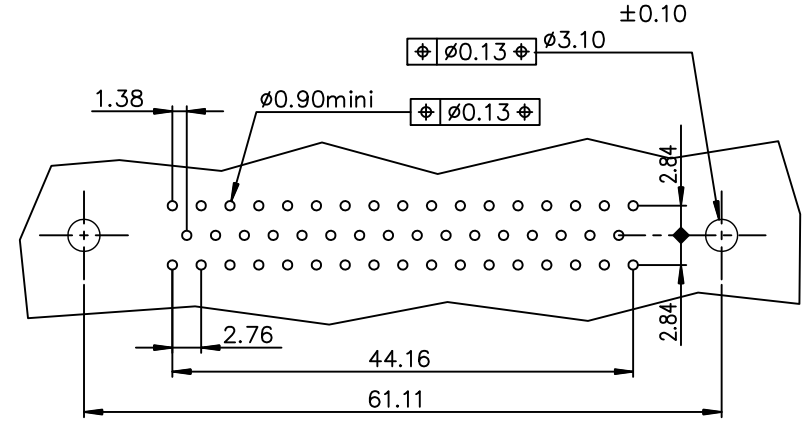

Plating: 4 --> flash AU  
Plating: 6 --> 0.76µ AU

Part number: D50P24A\*P\*00LF

X--> ØT = UNC 4-40  
L--> ØT = M3

GENERAL CHARACTERISTICS AND ROHS INFORMATIONS:  
SEE DRAWING C01-8646-0000

Notes:

1) The nut can protrude above the surface of insulator but maintaining the footprint dimension 6.0±0.15 mm.

mat'l. code		-		surface		ISO 1302		tolerance		ISO 406		ISO 1101		projection		product family	
litr		ecn no		dr		date		angles		linear		0.X±0.1		MM		D-SUB	
A		-		MPE		1997/10/29										title	
B		LS07-0281		MPE		2007/11/06						0.XX±0.1				MALE DELTA-D 50 EUROPE	
C		ELX-I-15331		AB		2013/07/24		0.XX±2'				0.XXX±0.1		scale 2:1		STRAIGHT SOLDER WITH NUT	
D		ELX-I-21256		AB		2015/07/14		dr		PEESSON		1997/10/27				dwg no	
								enrg		ALIAS.BABU		2013/07/24				sheet 1 of 1	
								chr		MITHUN.PAUL		2013/07/24				size	
								appd		BIJU.K.PAUL		2013/07/24				A3	
sheet		revision		D												type	
index		sheet		1												CUSTOMER Drawing	

