

LOC	DIST	REVISIONS					
DF	FO	TR	LTR	DESCRIPTION	DATE	OWN	APPR
		A		REV PER 063D-0415-01	10-01	CT	JM

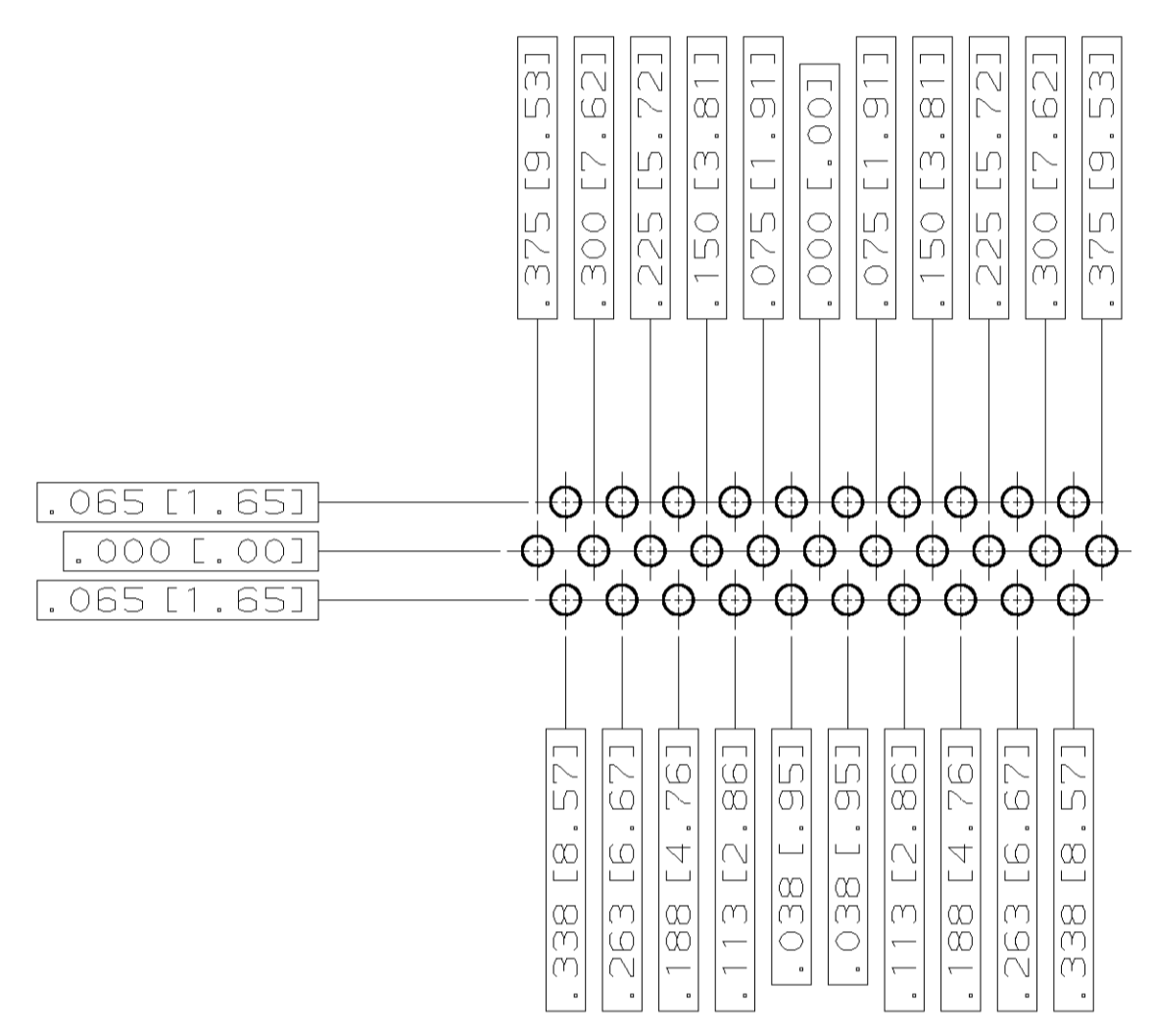
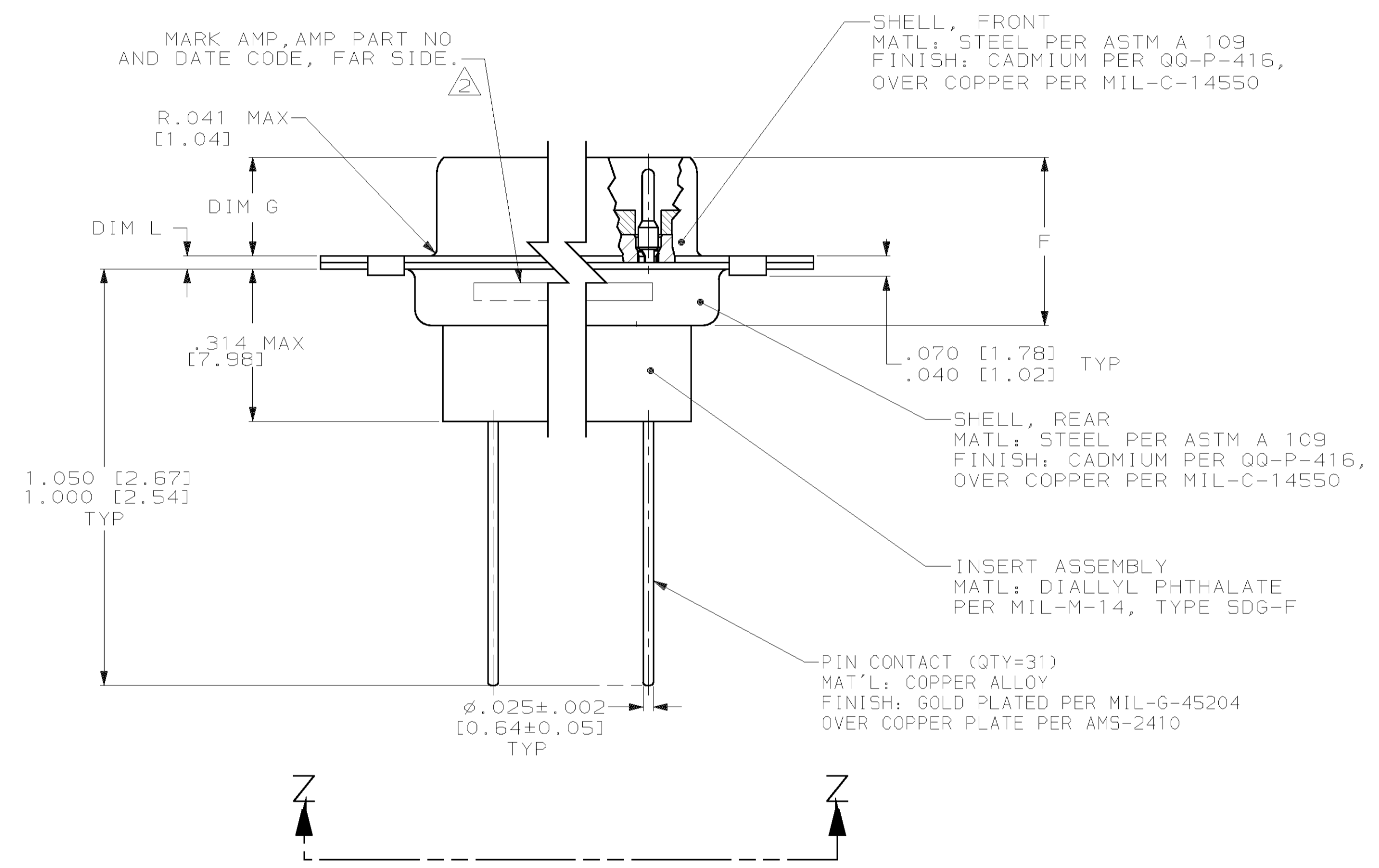
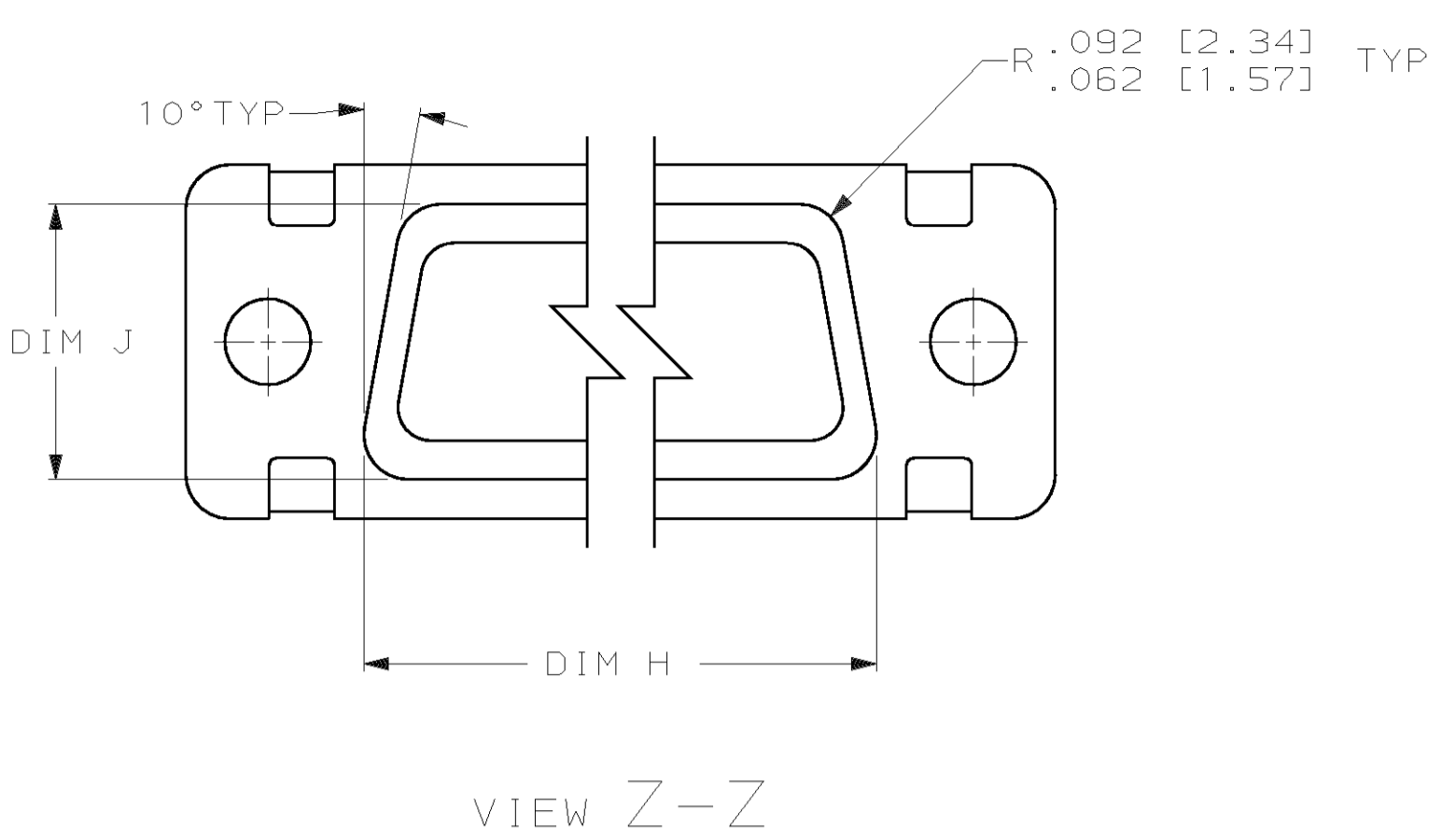
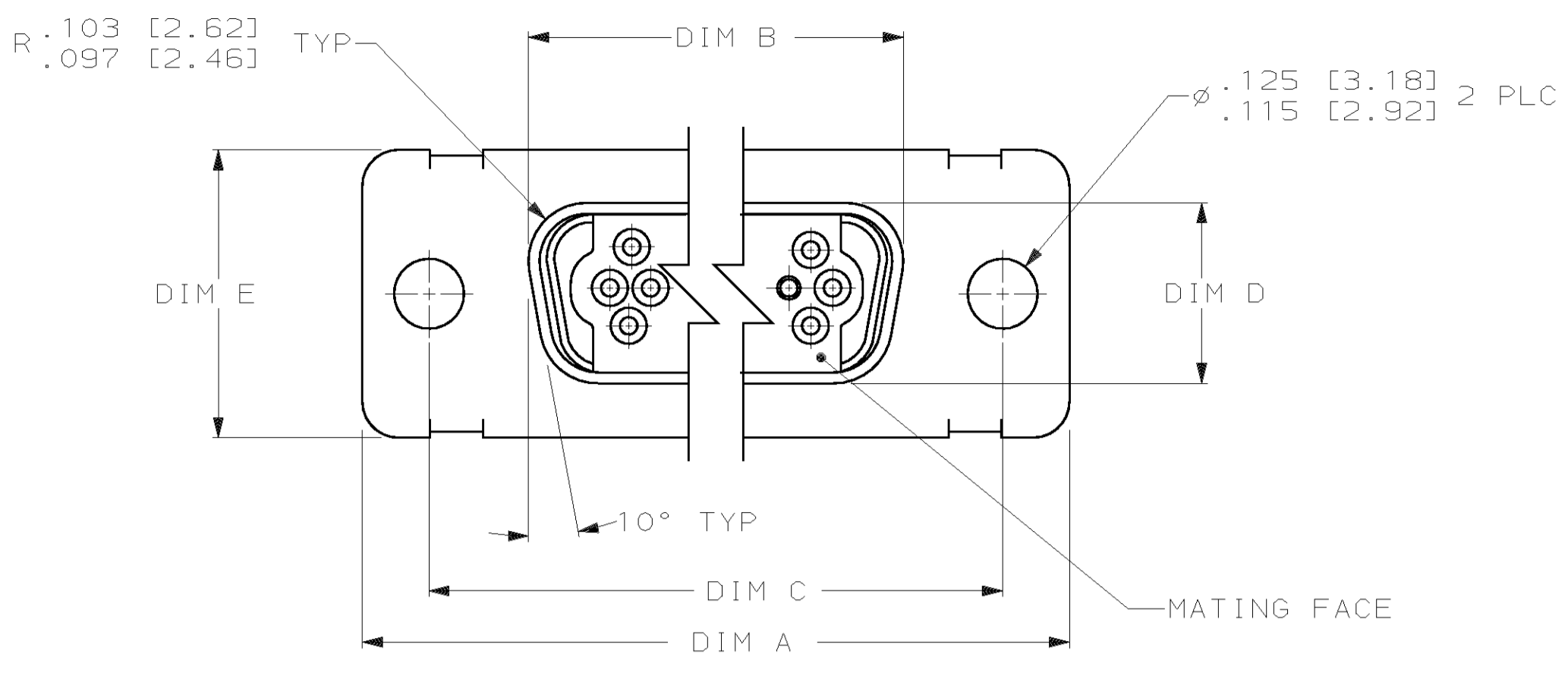

RECOMMENDED P.C. BOARD LAYOUT

- DIMENSIONS AND TOLERANCES PER ANSI Y14.5M-1982.
- MARK WITH .047 [1.19]-.062 [1.57] HIGH CHARACTERS. FAR SIDE REFERS TO THE WIDE SIDE OF THE KEYSTONE. NEAR SIDE REFERS TO THE NARROW SIDE OF THE KEYSTONE. SIZE 1 AND 2 SHALL BE MARKED AS FOLLOWS:
 A. "AMP" AND DATE CODE ON REAR SHELL, NEAR SIDE.
 B. AMP PART NUMBER ON REAR SHELL, FAR SIDE.
- .040 [1.02] DIAMETER HOLE RECOMMENDED FOR P.C. BOARD.
- REPLACEMENT CONTACT PART NO. 1484227-1.

.040 [1.02]	.432 [10.97]	1.093 [27.76]	.248 [6.30]	.439 [11.15]	.509 [12.93]	.316 [8.03]	1.317 [33.45]	.976 [24.79]	1.556 [39.52]	31	2	1484349-1
.020 [0.51]	.412 [10.46]	1.073 [27.25]	.238 [6.05]	.419 [10.64]	.479 [12.17]	.306 [7.77]	1.307 [33.20]	.966 [24.54]	1.526 [38.76]	NO OF POS	SHELL SIZE	PART NUMBER
L	J	H	G	F	E	D	C	B	A			

THIS DRAWING IS A CONTROLLED DOCUMENT.

DIMENSIONS: INCHES (mm)	TOLERANCES UNLESS OTHERWISE SPECIFIED:	DWN: C.C. THOMAS 7-26-01	AMP TYCO Electronics Corporation Harrisburg, PA 17105-3608
	0 PLC ±.0005	CHK: J. MARKEY 7-26-01	PLUG ASSY, DOUBLE DENSITY, SIZE 2, AMPLIMITE WITH CONTACTS
	1 PLC ±.0005	APPR: J. MARKEY 7-26-01	
	2 PLC ±.0005	PRODUCT SPEC: -	SIZE: A1
	3 PLC ±.0005	APPLICATION SPEC: -	CAGE CODE: 00779
	4 PLC ±.0005	WEIGHT: -	DRAWING NO: 1484349
MATERIAL: SEE CALLOUTS	FINISH: SEE CALLOUTS	CUSTOMER DRAWING	SCALE: 4:1