

**ARM[®] Cortex[®]-M
32-bit Microcontroller**

**NuMicro[™] Family
NuTiny-SDK-M0519
User Manual**

The information described in this document is the exclusive intellectual property of Nuvoton Technology Corporation and shall not be reproduced without permission from Nuvoton.

Nuvoton is providing this document only for reference purposes of NuMicro microcontroller based system design. Nuvoton assumes no responsibility for errors or omissions.

All data and specifications are subject to change without notice.

For additional information or questions, please contact: Nuvoton Technology Corporation.

www.nuvoton.com

Table of Contents

1 OVERVIEW 4

2 NUTINY-SDK-M0519 INTRODUCTION..... 5

 2.1 NuTiny -SDK-M0519 Jumper Description 6

 2.1.1 Power Setting 6

 2.1.2 Debug Connector 6

 2.1.3 USB Connector 6

 2.1.4 Extended Connector 6

 2.1.5 Reset Button..... 6

 2.1.6 Power Connector 6

 2.1.7 VCOM Enable 6

 2.2 Pin Assignment for Extended Connector 8

 2.3 NuTiny-SDK-M0519 PCB Placemen 10

3 How to Start NuTiny -SDK-M0519 on the Keil μ Vision[®] IDE 11

 3.1 Keil uVision[®] IDE Software Download and Install 11

 3.2 Nuvoton Nu-Link Driver Download and Install 11

 3.3 Hardware Setup..... 11

 3.4 Example Program..... 11

4 How to Start NuTiny -SDK-M0519 on the IAR Embedded Workbench..... 13

 4.1 IAR Embedded Workbench Software Download and Install 13

 4.2 Nuvoton Nu-Link Driver Download and Install 13

 4.3 Hardware Setup..... 13

 4.4 Example Program..... 13

5 Starting to Use Nu-Link-Me 3.0 VCOM Function..... 15

 5.1 Downloading and Installing VCOM Driver 15

 5.2 VCOM Mode Setting on NuTiny-SDK-M0519..... 16

 5.3 Setup on the Development Tool..... 16

 5.3.1 Check the Using UART on the Keil μ Vision[®] IDE..... 16

 5.3.2 Check the Target Device and Debug Setting 16

 5.3.3 Build and Download Code to NuTiny-SDK-M0519 18

 5.3.4 Open the Serial Port Terminal 19

 5.3.5 Reset Chip 19

6 NuTiny-SDK-M0519 Schematic..... 21

 6.1 NuTiny-EVB-M0519 Schematic 21

6.2 GPIO for 100 pin Schematic22

6.3 SDK Circuit Schematic.....23

6.4 Nu-Link-Me V3.0 Schematic24

7 REVISION HISTORY 25

1 OVERVIEW

NuTiny-SDK-M0519 is the specific development tool for NuMicro M0519 series. Users can use NuTiny-SDK-M0519 to develop and verify the application program easily.

NuTiny-SDK-M0519 includes two portions. One is NuTiny-EVB-M0519 and the other is Nu-Link-Me. NuTiny-EVB-M0519 is the evaluation board and Nu-Link-Me is its Debug Adaptor. Thus, users do not need other additional ICE or debug equipment.

The ARM[®] Cortex[®]-M0 core within NuMicro M0519 series can run up to 72 MHz with 128 Kbytes Flash program memory, 16 Kbytes SRAM, and 8 Kbytes Flash loader memory for In-System Programming (ISP) and In Application Program (IAP). The M0519 series is equipped with a variety of peripheral, such as GPIOs, Timers, Watchdog Timer (WDT), UART, SPI, I²C, 14 ch x 16-bit PWM, 16 ch x 12-bit ADC, Analog Comparator, two sets OPAs, Low Voltage Reset, and Brown-out Detector, and other peripheral.

2 NUTINY-SDK-M0519 INTRODUCTION

NuTiny-SDK-M0519 uses the M0519VE3AE as the target microcontroller. Figure 2-1 is NuTiny-SDK-M0519 for M0519 series, the left portion is called NuTiny-EVB-M0519 and the right portion is Debug Adaptor called Nu-Link-Me.

NuTiny-EVB-M0519 is similar to other development boards. Users can use it to develop and verify applications to emulate the real behavior. The on board chip covers M0519 series features. The NuTiny-EVB-M0519 can be a real system controller to design users' target systems, supports usb high speed interface, audio headphone out, audio line in and sdcad slot.

Nu-Link-Me is a Debug Adaptor. The Nu-Link-Me Debug Adaptor connects your PC's USB port to your target system (via Serial Wired Debug Port) and allows you to program and debug embedded programs on the target hardware. The Nu-Link-Me V3.0 also supports VCOM function, which gives users more flexibility when debug. To use Nu-Link-Me Debug adaptor with IAR or Keil, please refer to "Nuvoton NuMicro™ IAR ICE driver user manual" or Nuvoton NuMicro™ Keil ICE driver user manual" in detail. These two documents will be stored in the local hard disk when the user installs each driver. To use Nu-Link-Me 3.0 VCOM function, please refer to Chapter 5.

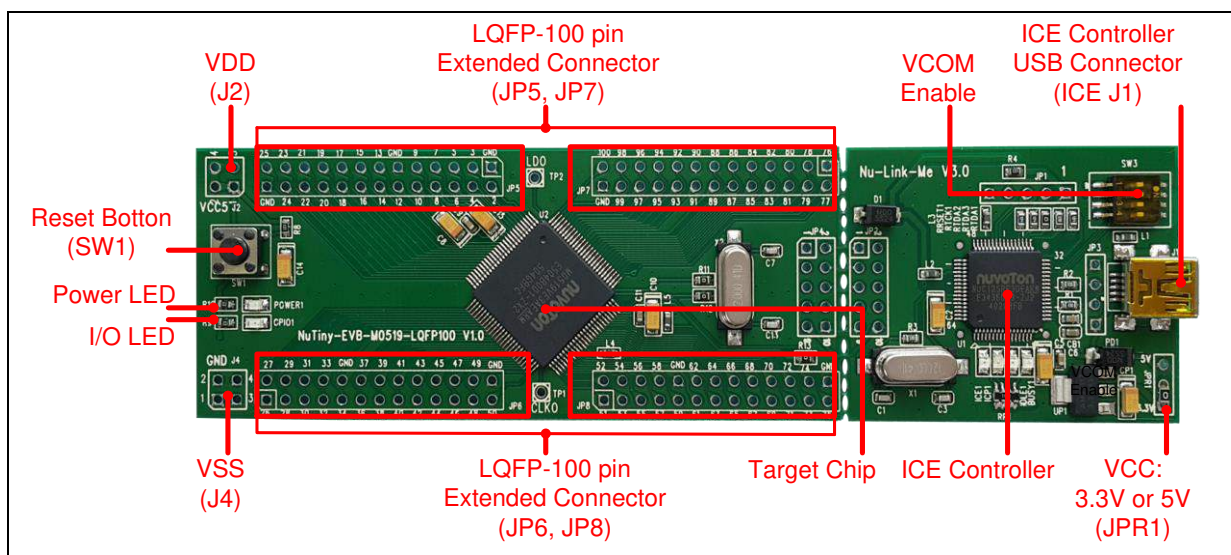

Figure 2-1 NuTiny-SDK-M0519 (PCB Board)

2.1 NuTiny -SDK-M0519 Jumper Description

2.1.1 Power Setting

- J1: USB port in Nu-Link-Me
- J2: VDD Voltage connector in NuTiny-EVB-M0519

Model	JPR1	J1 USB port	J2 VDD	MCU Voltage
Model 1	Select VCC33 (default)	Connect to PC	DC 3.3V output	DC 3.3V
Model 2	X	X	DC 2.5 V ~ 5.5 V Input	Voltage by J2 input

X: Unused.

2.1.2 Debug Connector

- JP4: Connector in target board (NuTiny-EVB-M0519) for connecting with Nuvoton ICE adaptor (Nu-Link-Me V3.0)
- JP2: Connector in ICE adaptor (Nu-Link-Me V3.0) for connecting with a target board (for example NuTiny-EVB-M0519)

2.1.3 USB Connector

- J1: Mini USB Connector in Nu-Link-Me V3.0 connected to a PC USB port

2.1.4 Extended Connector

- JP5, JP6, JP7 and JP8: Show all chip pins in NuTiny-EVB-M0519

2.1.5 Reset Button

- SW1: Reset button in NuTiny-EVB-M0519

2.1.6 Power Connector

- J2: VDD connector in NuTiny-EVB-M0519
- J4: VSS connector in NuTiny-EVB-M0519

2.1.7 VCOM Enable

- **SW3**: VCOM function enable for NuTiny-SDK-M0519. Switch SW3 on before power on to enable VCOM function. SW3 connects pin 31(P3.0/RXD) and pin 32(P3.1/TXD) in NuTiny-EVB-M0519 with pin 22(PB.1/TXD) and pin 21(PB.0/RXD) in Nuvoton ICE adaptor (Nu-Link-Me V3.0). SW3 connects pin 29(VCOM) in Nuvoton ICE adaptor (Nu-Link-Me V3.0) to GND to enable VCOM function.

Switch Pin Number	Function Name	UART0 Mode	VCOM Mode
1	ICE_TX	Off	On
2	ICE_RX	Off	On
3	VCOM_EN	Off	On
4	X	X	X

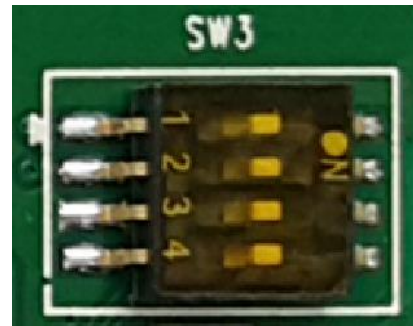

X: Unused.

2.2 Pin Assignment for Extended Connector

NuTiny-EVB-M0519 provides M0519VE3AE on board and the extended connector for (JP5, JP6, JP7 and JP8) for LQFP100-pin. Table 2-1 is the pin assignment for M0519.

Pin No	Pin Name	Pin No	Pin Name
01	PVSS	51	P5.3,SPI2_CLK
02	P9.7,SPI1_SS	52	P5.4,SPI2_SS
03	P3.7	53	P5.5,CLKO
04	P3.6	54	P0.3,PWM0_CH3,STADC
05	P3.5,TM1,I2C0_SCL	55	P0.2,PWM0_CH2,ECAP1_IC2
06	P3.4,TM0,I2C0_SDA	56	P0.1,PWM0_CH1,ECAP1_IC1
07	P3.2,INT0	57	P0.0,PWM0_CH0,ECAP1_IC0
08	P1.7,PWM1_BRAKE0	58	P8.7,ACMP0_O
09	LDO_CAP	59	P8.6
10	VDD	60	VSS
11	VSS	61	VDD
12	PA.1,UART1_RXD,I2C0_SCL	62	P6.7,ADC0_CH7
13	PA.0,UART1_TXD,I2C0_SDA	63	P6.6,ADC0_CH6
14	P5.7,PWM0_CH1	64	P6.5,ADC0_CH5,ACMP1_P
15	P5.6,PWM0_CH0	65	P6.4,ADC0_CH4,ACMP1_N
16	P1.6,PWM0_BRAKE0	66	P6.3,ADC0_CH3
17	P1.5,PWM1_CH5	67	P6.2,ADC0_CH2
18	P1.4,PWM1_CH4	68	P6.1,ADC0_CH1
19	P1.3,PWM1_CH3	69	P6.0,ADC0_CH0
20	P1.2,PWM1_CH2	70	P8.2,OP0_O
21	P4.4	71	P8.1,OP0_N
22	P4.5	72	P8.0,OP0_P
23	P4.0,ECAP1_IC0	73	AVSS
24	P4.1,ECAP1_IC1	74	AVDD
25	P4.2,ECAP1_IC2	75	VREF
26	P4.3	76	P7.7,ADC1_CH7
27	P3.3,INT1	77	P7.6,ADC1_CH6
28	P4.6,TM2	78	P7.5,ADC1_CH5,ACMP2_P

29	P1.1,PWM1_CH1	79	P7.4,ADC1_CH4,ACMP2_N
30	P1.0,PWM1_CH0	80	P7.3,ADC1_CH3
31	P3.0,UART0_RXD	81	P7.2,ADC1_CH2
32	P3.1,UART0_TXD,ACMP0_O	82	P7.1,ADC1_CH1
33	P4.7,TM3	83	P7.0,ADC1_CH0
34	VDD	84	P8.4,ACMP0_P
35	VSS	85	P8.3,ACMP0_N
36	P5.0,SPI0_MOSI,UART0_nRTS	86	P9.0,OP1_O
37	P5.1,SPI0_MISO,UART0_nCTS	87	P9.1,OP1_N
38	P2.7,SPI0_CLK,UART1_nRTS	88	P9.2,OP1_P
39	P2.6,SPI0_SS,UART1_nCTS	89	VDD
40	P2.5	90	VSS
41	P2.4	91	P8.5
42	P0.7,STADC	92	P9.3,PWM1_BRAKE1
43	P0.6,PWM0_BRAKE1	93	nRESET
44	P0.5,PWM0_CH5	94	XT1_OUT
45	P0.4,PWM0_CH4	95	XT1_IN
46	P2.3,ECAP0_IC0	96	ICE_DAT
47	P2.2,ECAP0_IC1	97	ICE_CLK
48	P2.1,ECAP0_IC2	98	P9.4,SPI1_CLK
49	P2.0,SPI2_MOSI,ACMP2_O	99	P9.5,SPI1_MISO
50	P5.2,SPI2_MISO,ACMP1_O	100	P9.6,SPI1_MOSI

Table 2-1 Pin Assignment for M0519

2.3 NuTiny-SDK-M0519 PCB Placemen

Users can refer to Figure 2-2 for the NuTiny-SDK-M0519 PCB placements.

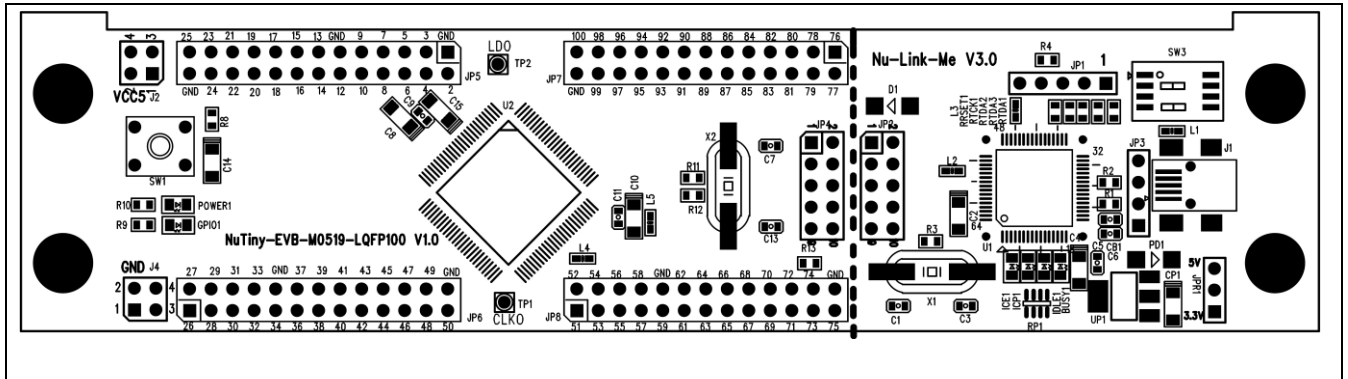

Figure 2-2 NuTiny-SDK-M0519 PCB Placement

3 HOW TO START NUTINY -SDK-M0519 ON THE KEIL MVISION® IDE

3.1 Keil uVision® IDE Software Download and Install

Please visit the Keil company website (<http://www.keil.com>) to download the Keil μ Vision® IDE and install the RVMDK

3.2 Nuvoton Nu-Link Driver Download and Install

Please visit the Nuvoton company NuMicro™ website (<http://www.nuvoton.com/NuMicro>) to download “NuMicro™ Keil μ Vision® IDE driver” file. When the Nu-Link driver has been well downloaded, please unzip the file and execute the “Nu-Link_Keil_Driver.exe” to install the driver.

3.3 Hardware Setup

The hardware setup is shown as Figure 3-1.

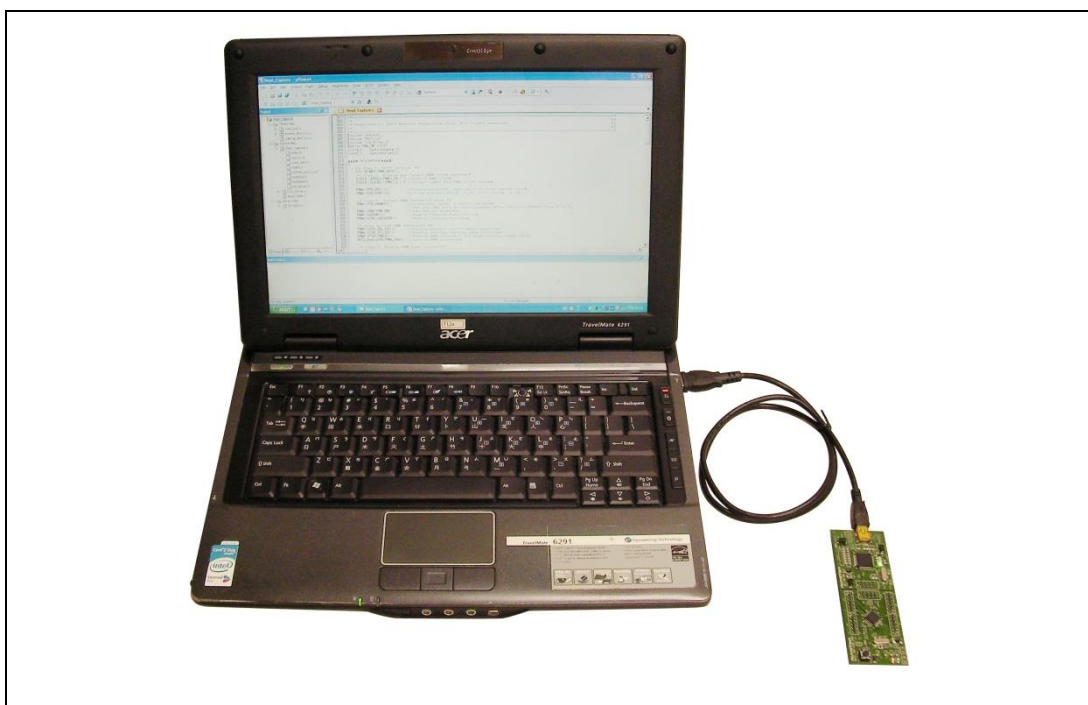

Figure 3-1 NuTiny-SDK-M0519 Hardware Setup

3.4 Example Program

This example demonstrates the ease of downloading and debugging an application on a NuTiny-SDK-M0519 board. It can be found on Figure 3-2 list directory and downloaded from Nuvoton NuMicro™ website.

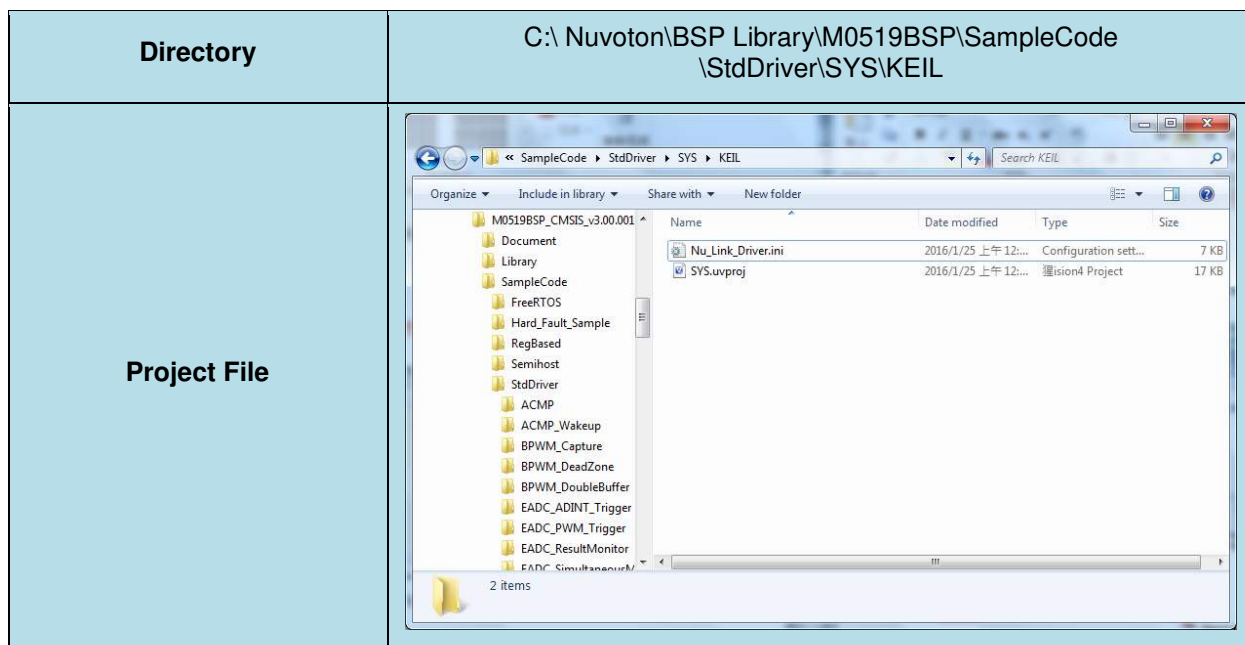









Figure 3-2 Example Directory

This sample code will show some functions about system manager controller and clock controller.

-  Start uVision®
- Project – Open
Open the SYS.uvproj project file
-  Project – Build
Compile and link the SYS application
-  Flash – Download
Program the application code into on-chip Flash ROM
-  Start debug mode
When using the debugger commands, you may:
 - ◆  Review variables in the watch window
 - ◆  Single step through code
 - ◆  Reset the device
 - ◆  Run the application

4 HOW TO START NUTINY -SDK-M0519 ON THE IAR EMBEDDED WORKBENCH

4.1 IAR Embedded Workbench Software Download and Install

Please connect to IAR company website (<http://www.iar.com>) to download the IAR Embedded Workbench and install the EWARM.

4.2 Nuvoton Nu-Link Driver Download and Install

Please visit the Nuvoton company NuMicro™ website (<http://www.nuvoton.com/NuMicro>) to download the “NuMicro™ IAR EWARM Driver” file. When the Nu-Link driver has been well downloaded, please unzip the file and execute the “Nu-Link_Keil_Driver.exe” to install the driver.

4.3 Hardware Setup

The hardware setup is shown as Figure 4-1.

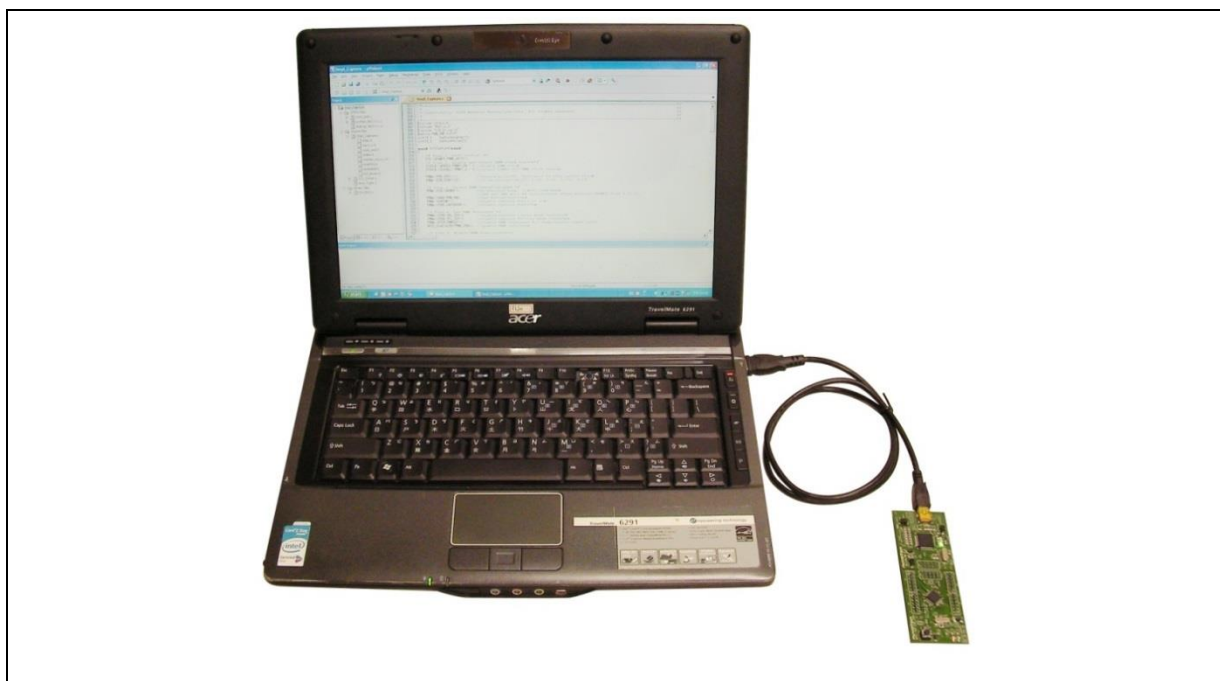

Figure 4-1 NuTiny-SDK-M0519 Hardware Setup

4.4 Example Program

This example demonstrates the ease of downloading and debugging an application on a NuTiny-SDK-M0519 board. It can be found on Figure 4-2 list directory and downloaded from Nuvoton NuMicro™ website.

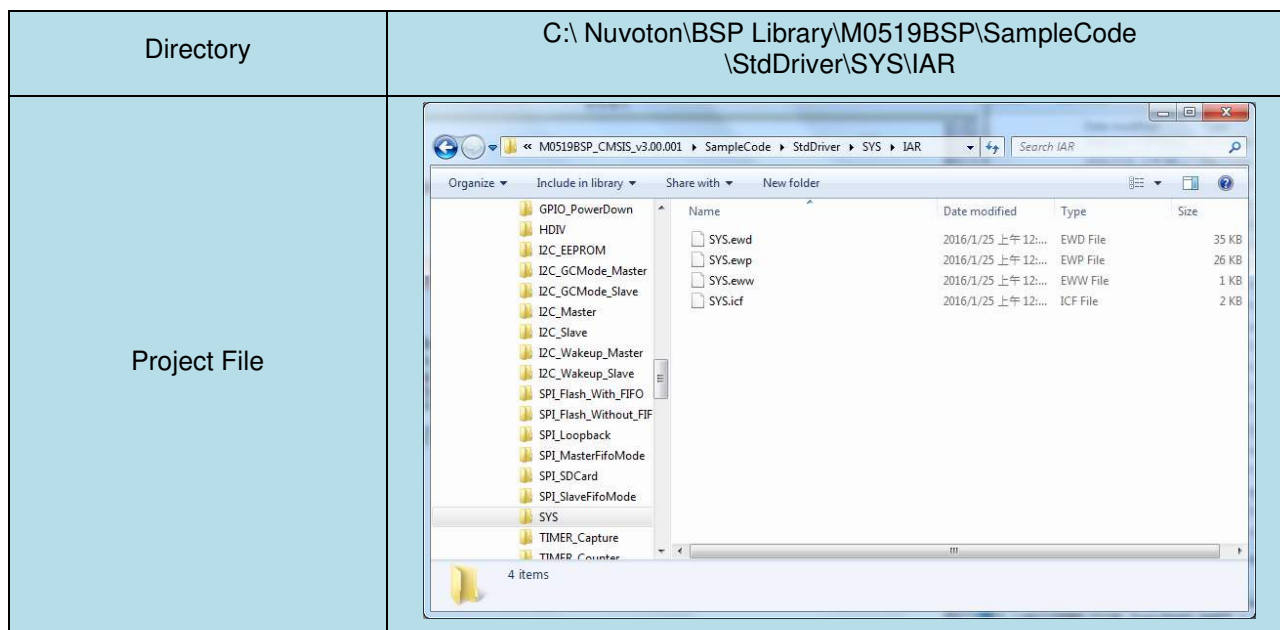







Figure 4-2 Example Directory

This sample code will show some functions about system manager controller and clock controller.

-  Start IAR Embedded Workbench
-  Project – Download and Debug
Program the application code into on-chip Flash ROM
- File-Open-Workspace
Open the SYS.eww workspace file
-  Single step through code
-  Reset the device
-  Project - Make
Compile and link the SYS application
-  Run the application

5 STARTING TO USE NU-LINK-ME 3.0 VCOM FUNCTION

5.1 Downloading and Installing VCOM Driver

Please connect to Nuvoton NuMicro™ website (<http://www.nuvoton.com/NuMicro>) to download the “NuMicro™ ICP Programming Tool” file. After the ICP Programming Tool driver is downloaded, please unzip the file and execute the “ICP Programming Tool.exe”. Simply follow the installation and optional steps to install ICP Programming Tool and Nu-Link USB Driver, which included VCOM driver.

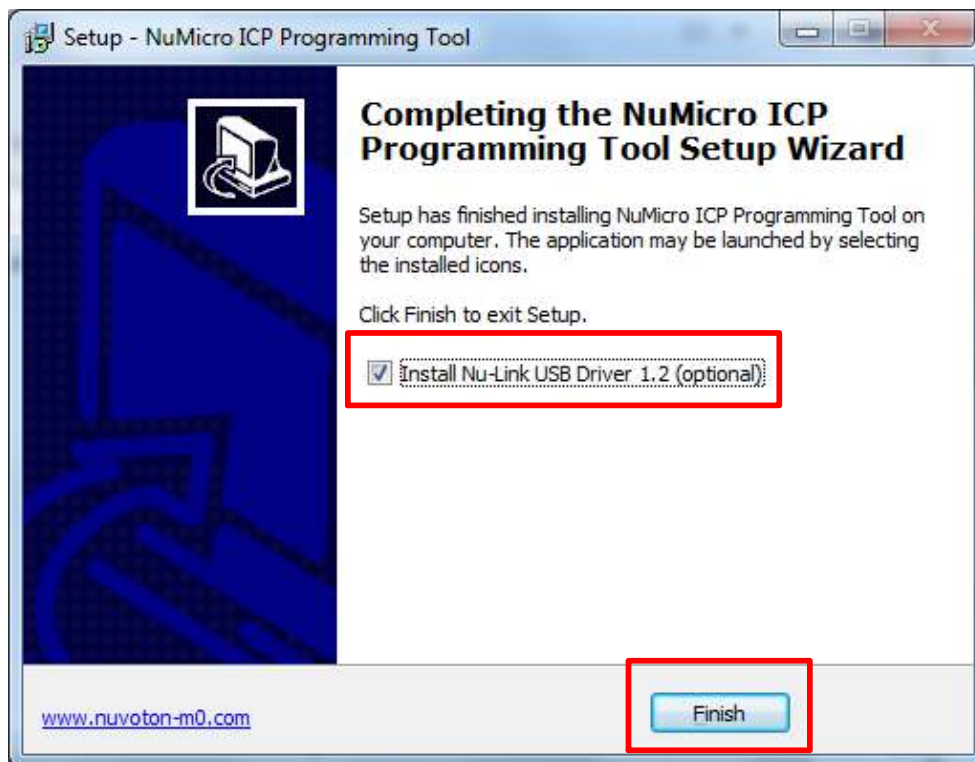

Figure 5-1 Optional Step after ICP Programming Tool Installation

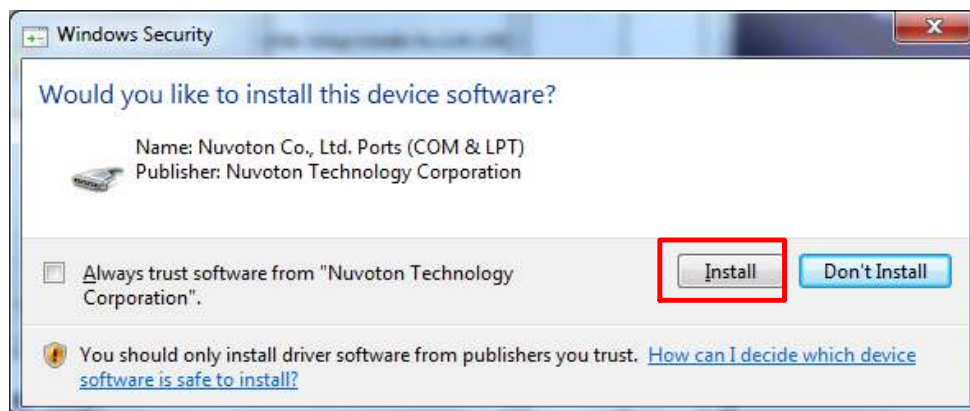

Figure 5-2 Install Nuvoton COM&LPT Driver

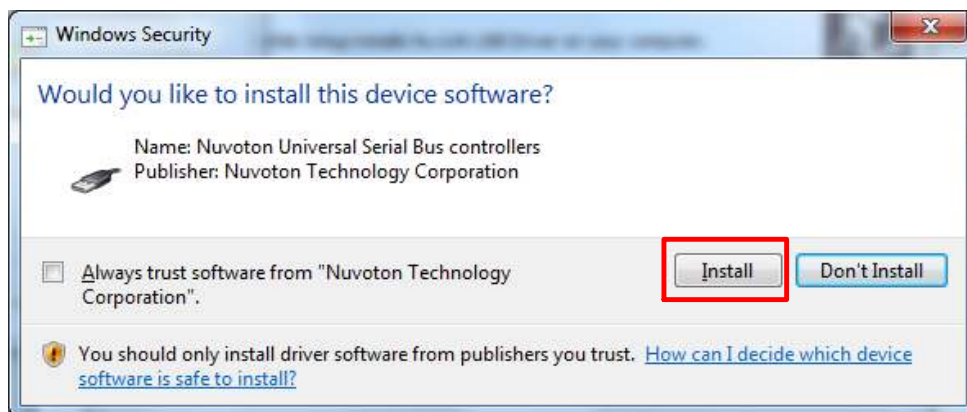

Figure 5-3 Install Nuvoton Universal Serial Bus Controllers

5.2 VCOM Mode Setting on NuTiny-SDK-M0519

Before the NuTiny-SDK-M0519 is connected to the PC, please enable SW3 VCOM function by switching on SW3. The NuTiny-EVB-M0519 transmits through UART0 to VCOM to send out data. Switch SW3 off when using UART0 function without VCOM function.

5.3 Setup on the Development Tool

The example is demonstrated on the Keil μ Vision[®] IDE.

5.3.1 Check the Using UART on the Keil μ Vision[®] IDE

Please open the project and find system_M0519.h to check the using UART in DEBUG_PORT, which has to be the same as the using UART in the NuTiny-EVB-M0519.

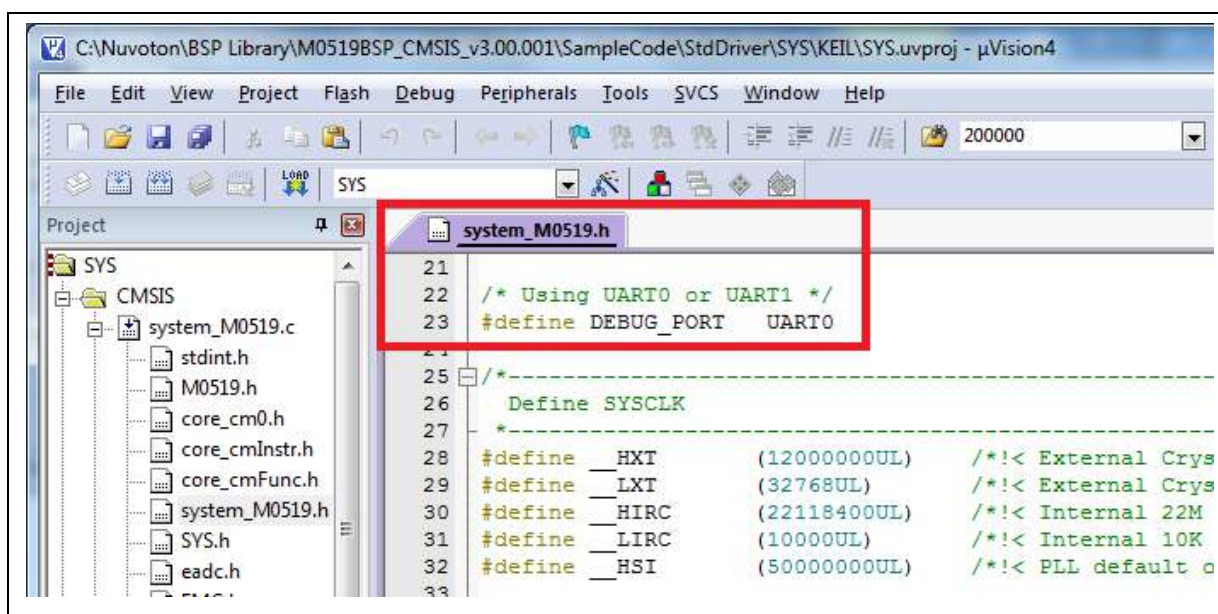
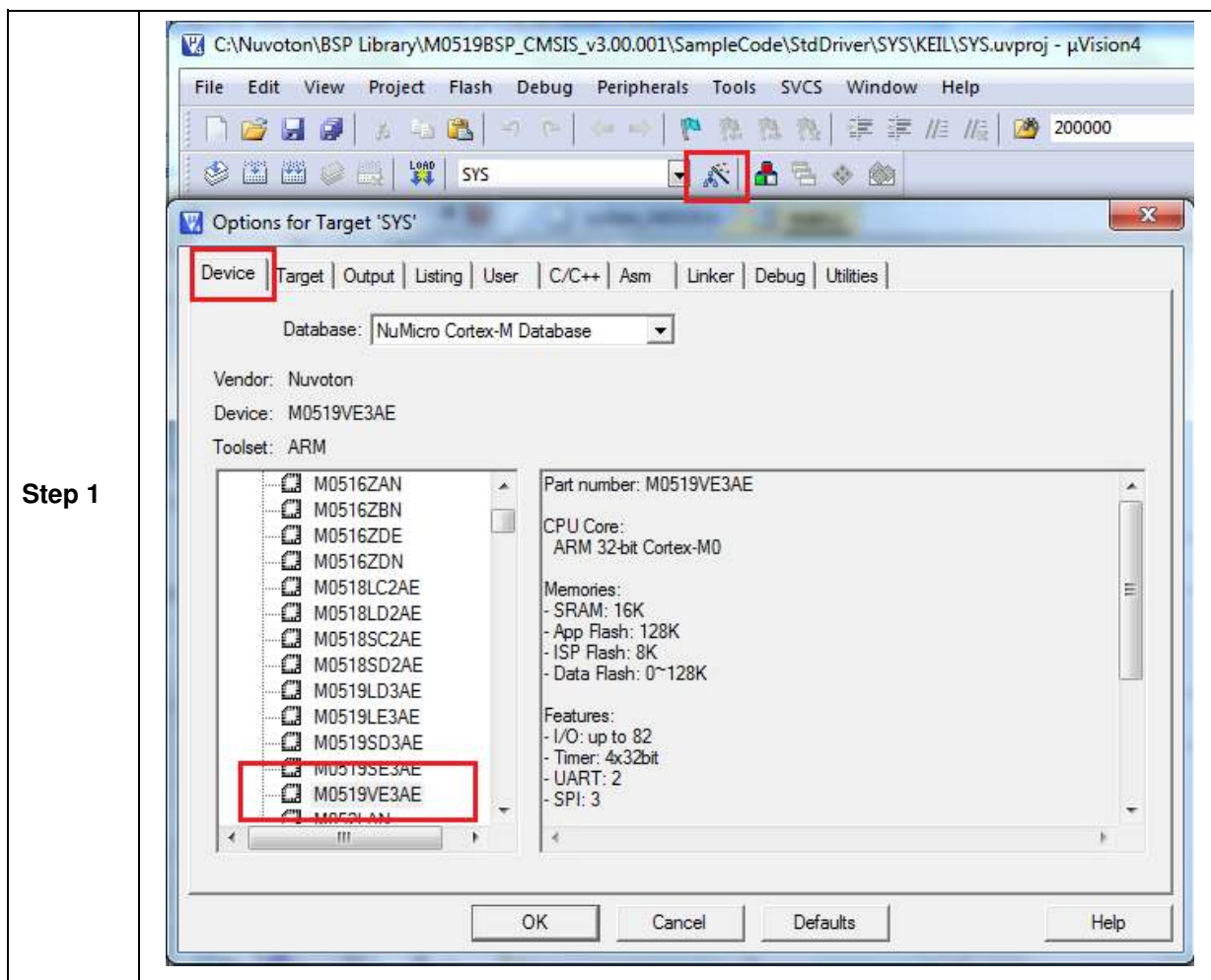

Figure 5-4 The Using UART on Keil μ Vision[®] IDE

5.3.2 Check the Target Device and Debug Setting

The target device has to be the same as the setting in Debug. Please click "Target Option" to

open the Option windows, and find the setting in “Device”, “Debug”, and “Utilities” page. Please follow the steps below to check the setting.



Step 2

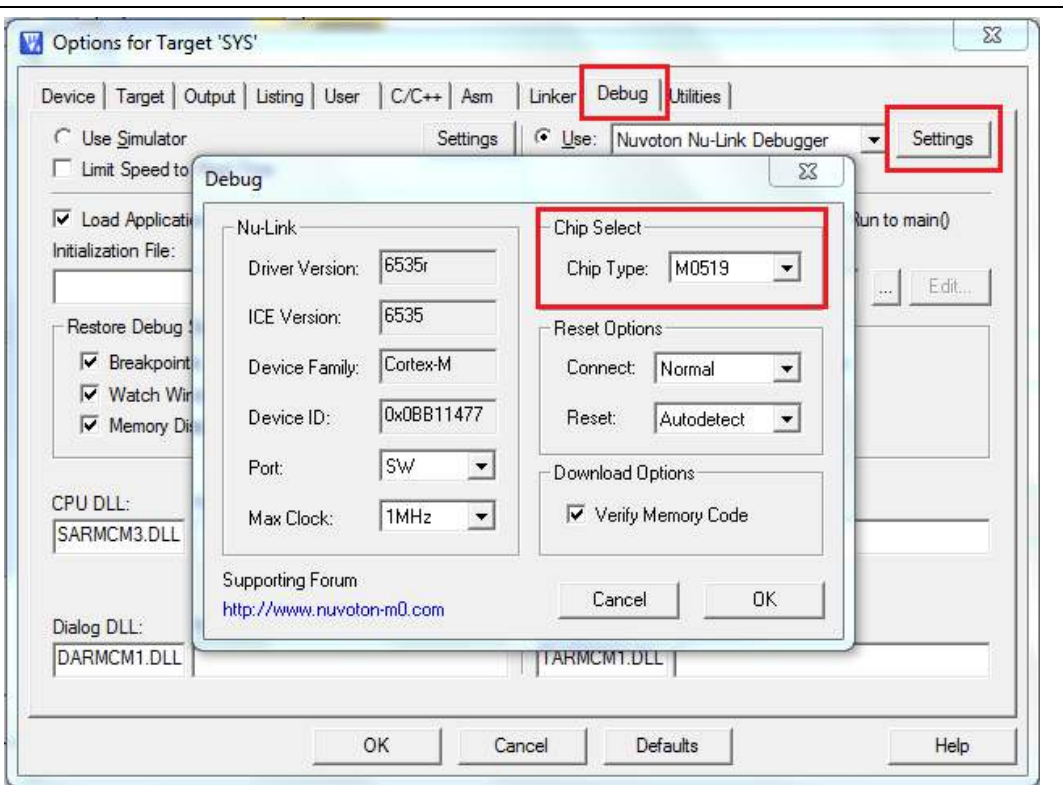

Step 3

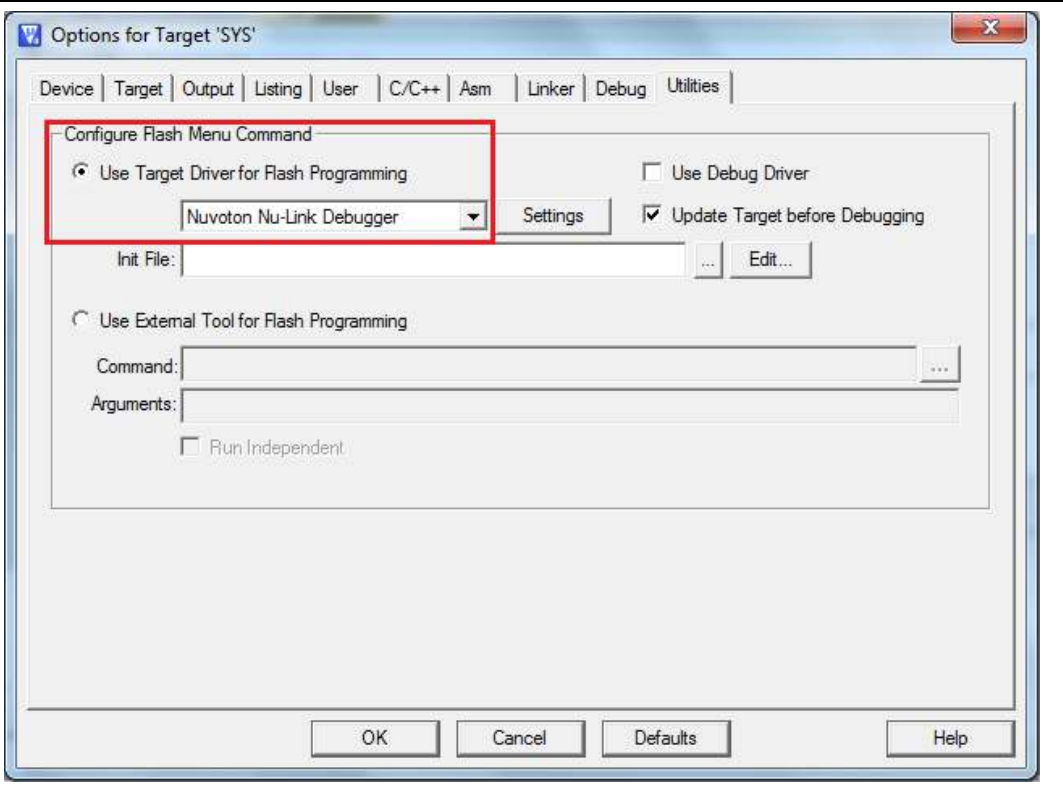

5.3.3 Build and Download Code to NuTiny-SDK-M0519

Please build the project and download code to NuTiny-SDK-M0519.

5.3.4 Open the Serial Port Terminal

User can use serial port terminal, PuTTY for example, to print out debug message.

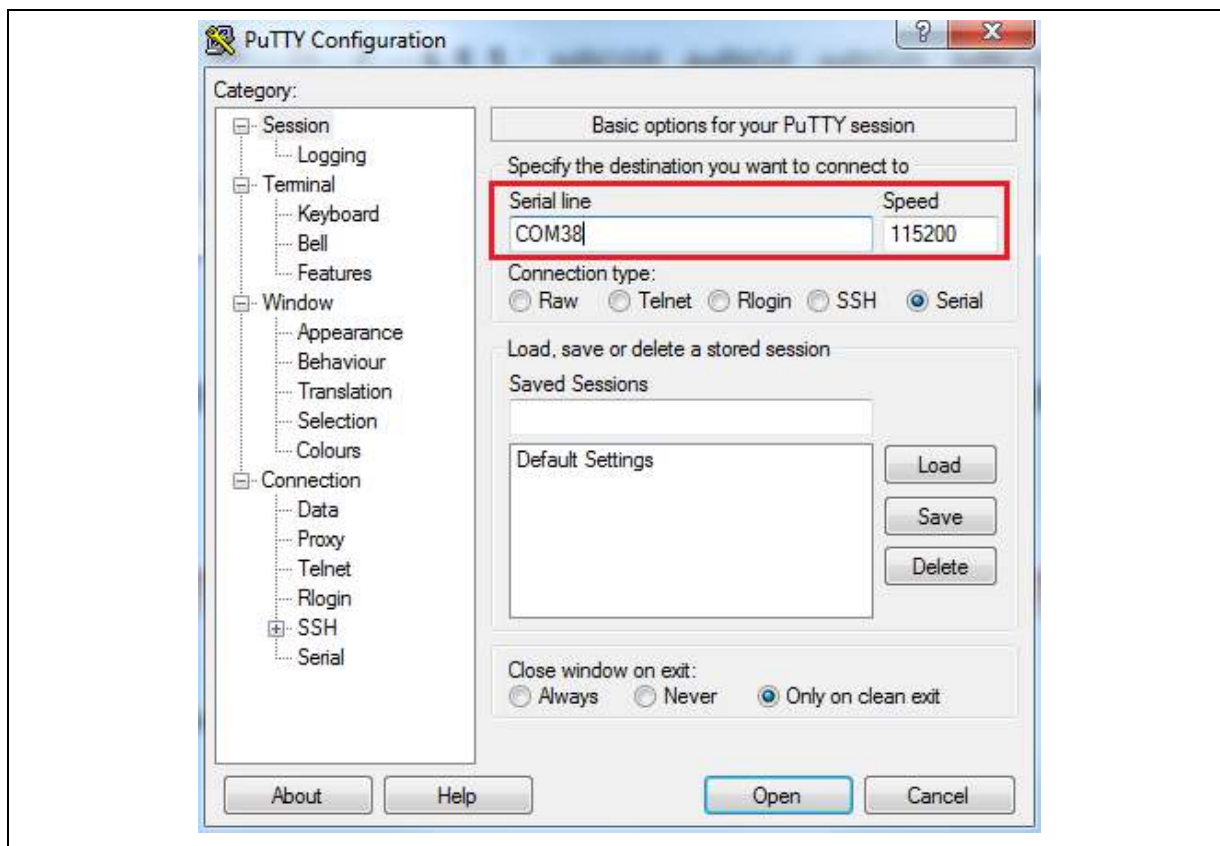

Figure 5-5 Set Baud Rate

5.3.5 Reset Chip

After pushing the reset button, the chip will reprogram application and print out debug message.

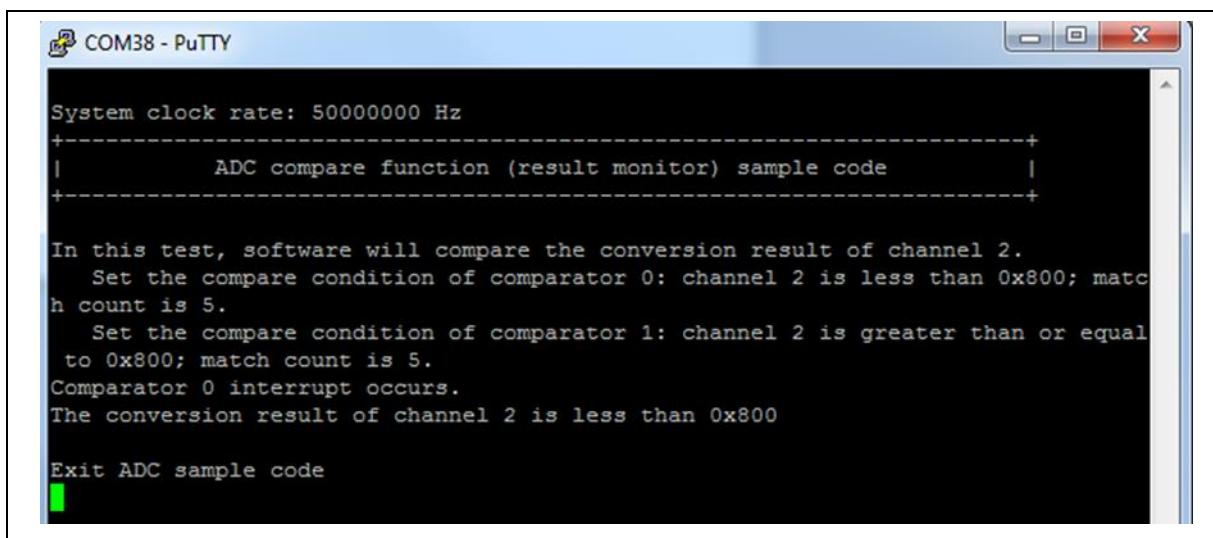
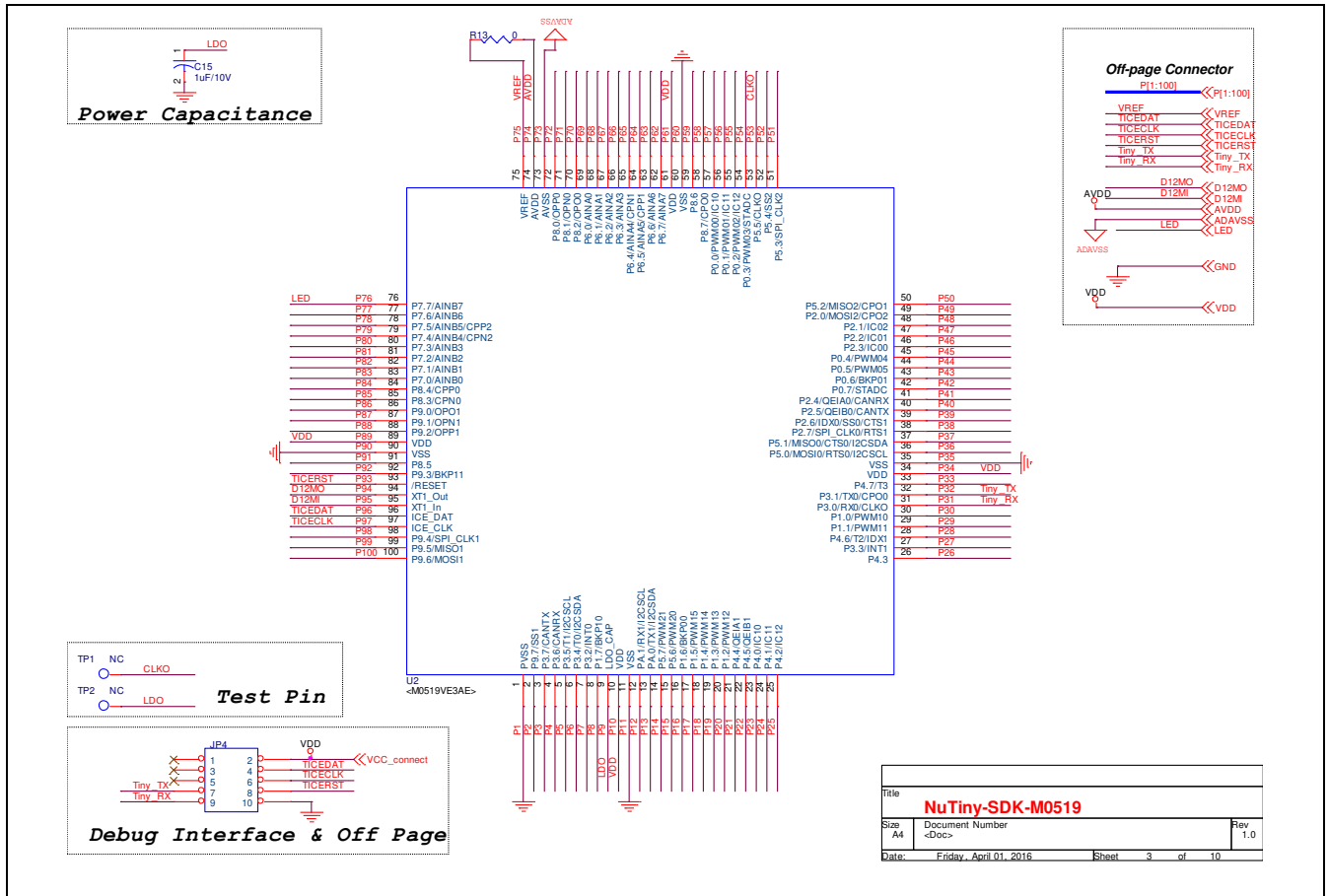

Figure 5-6 Serial Port Terminal Windows

Notice: Please switch SW3 on before the NuTiny-SDK-M0519 connects to the PC. When the NuTiny-SDK-M0519 connects to the PC with SW3 switch on, PC will detect VCOM as a USB device and the detection will only be processed once. VCOM will not function if switch on SW3 after the connection.

6 NUTINY-SDK-M0519 SCHEMATIC

6.1 NuTiny-EVB-M0519 Schematic



6.2 GPIO for 100 pin Schematic

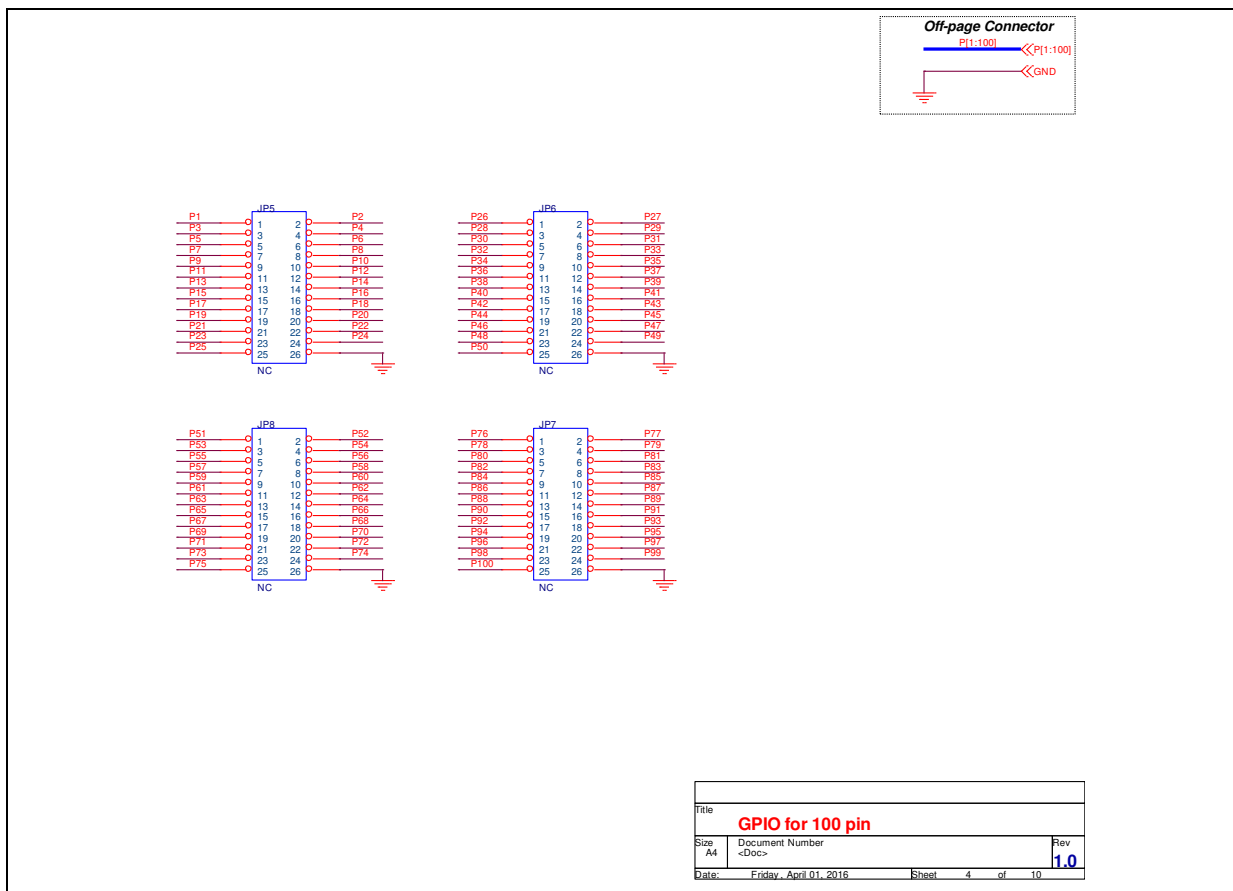

6.3 SDK Circuit Schematic

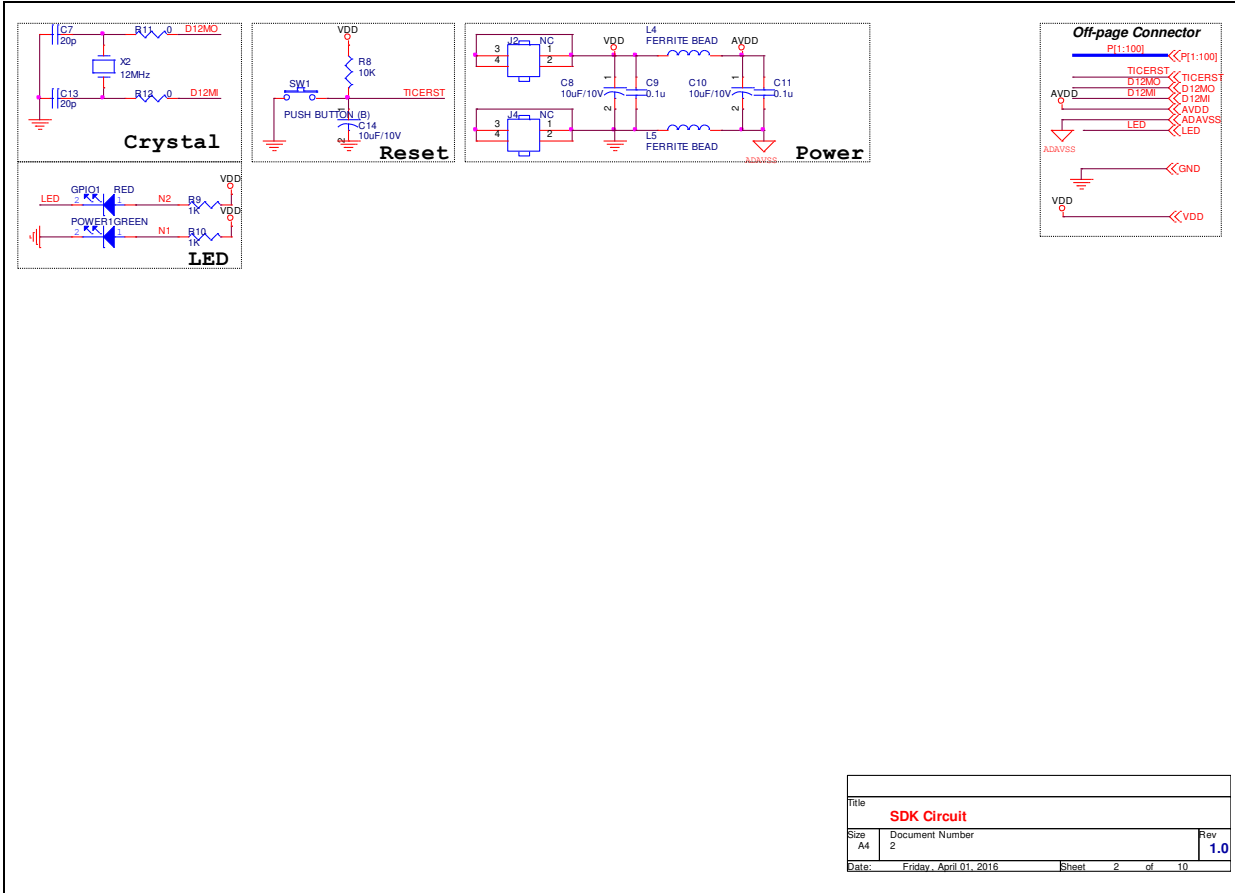

Title		SDK Circuit	
Size	A4	Document Number	2
Date:	Friday, April 01, 2016	Sheet	2 of 10
		Rev	1.0

6.4 Nu-Link-Me V3.0 Schematic

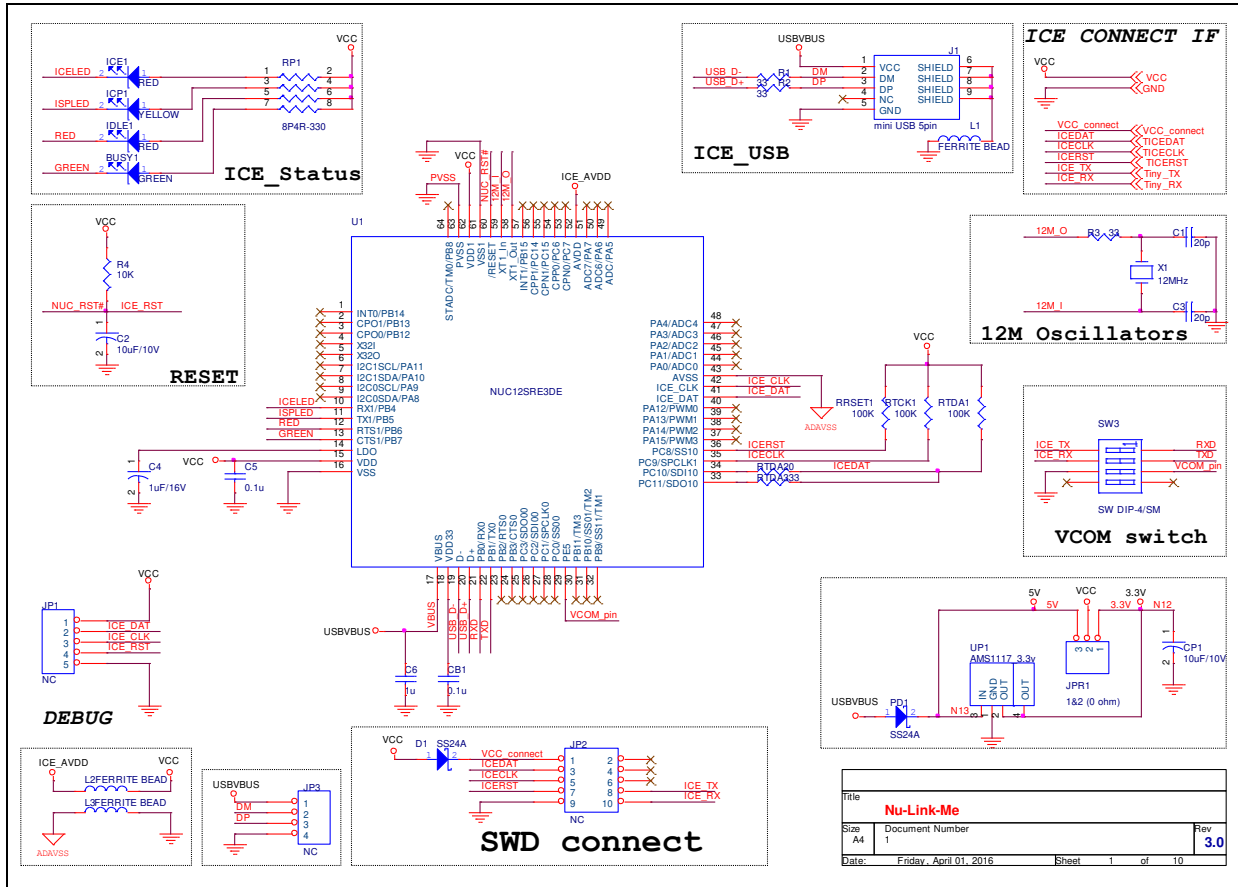

7 REVISION HISTORY

Date	Revision	Description
2016.04.26	1.00	1. Initially issued.

Important Notice

Nuvoton Products are neither intended nor warranted for usage in systems or equipment, any malfunction or failure of which may cause loss of human life, bodily injury or severe property damage. Such applications are deemed, “Insecure Usage”.

Insecure usage includes, but is not limited to: equipment for surgical implementation, atomic energy control instruments, airplane or spaceship instruments, the control or operation of dynamic, brake or safety systems designed for vehicular use, traffic signal instruments, all types of safety devices, and other applications intended to support or sustain life.

All Insecure Usage shall be made at customer’s risk, and in the event that third parties lay claims to Nuvoton as a result of customer’s Insecure Usage, customer shall indemnify the damages and liabilities thus incurred by Nuvoton.

*Please note that all data and specifications are subject to change without notice.
All the trademarks of products and companies mentioned in this datasheet belong to their respective owners.*