

# MINI MCR-2-(2)I-(2)I-ILP(-SP)

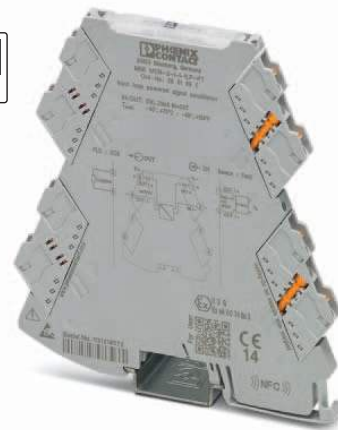

Input loop-powered 2-way isolator,  
single and two-channel

Data sheet  
106294\_en\_01

© PHOENIX CONTACT 2017-08-23

## 1 Description

The single- or dual-channel input loop powered 2-way isolator with plug-in connection technology is used for the electrical isolation and filtering of analog signals.

The device is powered via the current loop of the sensor. Therefore, no additional power supply is necessary.

Input signal = output signal: 0(4) mA ... 20 mA

### Features

- Single and two-channel input loop-powered 2-way isolator with plug-in connection technology
- Input and output signal range 0 ... 20 mA or 4 ... 20 mA
- Approval for Ex-zone 2 (nA)
- Screw or push-in connection available
- Reinforced insulation according to IEC 61010-1



#### **WARNING: Correct usage in potentially explosive areas**

The module is a category 3 item of electrical equipment. It is absolutely vital to follow the instructions provided here during installation and observe the information in the "Safety regulations and installation notes".



This device offers the option of NFC communication.

You can use the MINI Analog Pro Smartphone app to call-up comprehensive module information via the NFC interface of your Smartphone.

The MINI Analog Pro Smartphone app is available to you free.



Make sure you always use the latest documentation.

It can be downloaded from the product at [phoenixcontact.net/products](http://phoenixcontact.net/products).

This document is valid for the products listed in the "Ordering data".

<b>2</b>	<b>Table of contents</b>	
1	Description .....	1
2	Table of contents .....	2
3	Ordering data .....	3
4	Technical data .....	6
5	Safety regulations and installation notes.....	8
	5.1 Installation notes .....	8
	5.2 Installation in Zone 2.....	8
	5.3 UL Notes .....	9
6	Installation .....	10
	6.1 Connection notes .....	10
	6.2 Structure .....	10
	6.3 Block diagram.....	11
	6.4 Assembly.....	11
	6.5 FASTCON Pro plugs .....	11
	6.6 Current measurement .....	12
	6.7 Marking.....	12
7	Method of operation.....	13

### 3 Ordering data

Description	Type	Order No.	Pcs./Pkt.
Single-channel input loop-powered 2-way isolator with plug-in connection technology for the electrical isolation of analog signals. Input signal = output signal: 0(4) mA ... 20 mA. Screw connection technology.	MINI MCR-2-I-I-ILP	2901994	1
Single-channel input loop-powered 2-way isolator with plug-in connection technology for the electrical isolation of analog signals. Input signal = output signal: 0(4) mA ... 20 mA. Push-in connection technology.	MINI MCR-2-I-I-ILP-PT	2901995	1
Two-channel input loop-powered 2-way isolator with plug-in connection technology for the electrical isolation of analog signals. Input signal = output signal: 0(4) mA ... 20 mA. Screw connection technology.	MINI MCR-2-2I-2I-ILP	2901996	1
Two-channel input loop-powered 2-way isolator with plug-in connection technology for the electrical isolation of analog signals. Input signal = output signal: 0(4) mA ... 20 mA. Push-in connection technology.	MINI MCR-2-2I-2I-ILP-PT	2901997	1
Accessories	Type	Order No.	Pcs./Pkt.
Eight MINI Analog Pro signal conditioners and measuring transducers can be connected to a controller with minimal cabling effort and without any errors using system adapters and system cabling.	MINI MCR-2-V8-FLK 16	2901993	1
Eight MINI Analog Pro signal conditioners and measuring transducers can be quickly and easily integrated into a Modbus/RTU network via a communication adapter.	MINI MCR-2-V8-MOD-RTU	2905634	1
Eight MINI Analog Pro signal conditioners and measuring transducers can be quickly and easily integrated into a Modbus/TCP network via a communication adapter.	MINI MCR-2-V8-MOD-TCP	2905635	1
Eight MINI Analog Pro signal conditioners and measuring transducers can be quickly and easily integrated into a PROFIBUS DP network via a communication adapter.	MINI MCR-2-V8-PB-DP	2905636	1
Marker for end clamp, Sheet, white, unlabeled, can be labeled with: THERMOMARK PRIME, THERMOMARK CARD, BLUEMARK CLED, BLUEMARK LED, TOPMARK LASER, Mounting type: snapped into marker carrier, Lettering field: 30 x 5 mm	UCT-EM (30X5)	0801505	10
Marker for end clamp, can be ordered: by sheet, white, labeled according to customer specifications, Mounting type: snapped into marker carrier, Lettering field: 30 x 5 mm	UCT-EM (30X5) CUS	0801589	1
Marker for end clamp, Sheet, yellow, unlabeled, can be labeled with: THERMOMARK PRIME, THERMOMARK CARD, BLUEMARK CLED, BLUEMARK LED, TOPMARK LASER, Mounting type: snapped into marker carrier, Lettering field: 30 x 5 mm	UCT-EM (30X5) YE	0830340	10

<b>Accessories</b>	<b>Type</b>	<b>Order No.</b>	<b>Pcs./Pkt.</b>
Marker for end clamp, can be ordered: by sheet, yellow, labeled according to customer specifications, Mounting type: snapped into marker carrier, Lettering field: 30 x 5 mm	UCT-EM (30X5) YE CUS	0830348	1
Plastic label, Sheet, white, unlabeled, can be labeled with: BLUEMARK CLED, BLUEMARK LED, CMS-P1-PLOTTER, PLOTMARK, Mounting type: adhesive, Lettering field: 15 x 5 mm	UC-EMLP (15X5)	0819301	10
Plastic label, can be ordered: by sheet, white, labeled according to customer specifications, Mounting type: adhesive, Lettering field: 15 x 5 mm	UC-EMLP (15X5) CUS	0824550	1
Plastic label, Sheet, white, unlabeled, can be labeled with: BLUEMARK CLED, BLUEMARK LED, CMS-P1-PLOTTER, THERMOMARK CARD, THERMOMARK PRIME, PLOTMARK, Mounting type: adhesive, Lettering field: 15 x 5 mm	UC-EMLP (15X5)L	0820138	5
Plastic label, can be ordered: by sheet, white, labeled according to customer specifications, Mounting type: adhesive, Lettering field: 15 x 5 mm	UC-EMLP (15X5)L CUS	0824552	1
Plastic label, Sheet, yellow, unlabeled, can be labeled with: BLUEMARK CLED, BLUEMARK LED, CMS-P1-PLOTTER, PLOTMARK, Mounting type: adhesive, Lettering field: 15 x 5 mm	UC-EMLP (15X5) YE	0822615	10
Plastic label, can be ordered: by sheet, yellow, labeled according to customer specifications, Mounting type: adhesive, Lettering field: 15 x 5 mm	UC-EMLP (15X5) YE CUS	0824551	1
Plastic label, Sheet, yellow, unlabeled, can be labeled with: BLUEMARK CLED, BLUEMARK LED, CMS-P1-PLOTTER, Mounting type: adhesive, Lettering field: 15 x 5 mm	UC-EMLP (15X5)L YE	0825325	5
Plastic label, can be ordered: by sheet, yellow, labeled according to customer specifications, Mounting type: adhesive, Lettering field: 15 x 5 mm	UC-EMLP (15X5)L YE CUS	0826680	1
Plastic label, Sheet, silver, unlabeled, can be labeled with: BLUEMARK CLED, BLUEMARK LED, CMS-P1-PLOTTER, PLOTMARK, Mounting type: adhesive, Lettering field: 15 x 5 mm	UC-EMLP (15X5) SR	0828095	10
Plastic label, can be ordered: by sheet, silver, labeled according to customer specifications, Mounting type: adhesive, Lettering field: 15 x 5 mm	UC-EMLP (15X5) SR CUS	0828099	1
Plastic label, Sheet, silver, unlabeled, can be labeled with: BLUEMARK CLED, BLUEMARK LED, CMS-P1-PLOTTER, PLOTMARK, Mounting type: adhesive, Lettering field: 15 x 5 mm	UC-EMLP (15X5)L SR	0828103	5
Plastic label, Card, white, unlabeled, can be labeled with: THERMOMARK PRIME, THERMOMARK CARD, Mounting type: adhesive, Lettering field: 15 x 5 mm	US-EMLP (15X5)	0828790	10

Accessories	Type	Order No.	Pcs./Pkt.
Plastic label, can be ordered: By card, white, labeled according to customer specifications, Mounting type: adhesive, Lettering field: 15 x 5 mm	US-EMLP (15X5) CUS	0830076	1
Plastic label, Card, yellow, unlabeled, can be labeled with: THERMOMARK PRIME, THERMOMARK CARD, Mounting type: adhesive, Lettering field: 15 x 5 mm	US-EMLP (15X5) YE	0828873	10
Plastic label, can be ordered: By card, yellow, labeled according to customer specifications, Mounting type: adhesive, Lettering field: 15 x 5 mm	US-EMLP (15X5) YE CUS	0830077	1
Plastic label, Card, silver, unlabeled, can be labeled with: THERMOMARK PRIME, THERMOMARK CARD, Mounting type: adhesive, Lettering field: 15 x 5 mm	US-EMLP (15X5) SR	0828874	10
Plastic label, can be ordered: By card, silver, labeled according to customer specifications, Mounting type: adhesive, Lettering field: 15 x 5 mm	US-EMLP (15X5) SR CUS	0830078	1
Marker strip, Roll, white, unlabeled, can be labeled with: THERMOMARK ROLL, THERMOMARK ROLL X1, THERMOMARK ROLLMASTER 300/600, THERMOMARK X1.2, THERMOMARK S1.1, Mounting type: adhesive, for terminal block width: 5 mm, Lettering field: continuous x 5 mm	SK 5,0 WH:REEL	0805221	1

## 4 Technical data

Input		
Description of the input	Current input	
Number of inputs	1 / 2	
Configurable/programmable	no	
Current input signal	0 mA ... 20 mA 4 mA ... 20 mA	
Response current	approx. 200 $\mu$ A	
Input voltage limitation	30 V	
Voltage dissipation	3.1 V (I = 20 mA)	
Output		
Output description	Current output	
Number of outputs	1 / 2	
Current output signal	0 mA ... 20 mA 4 mA ... 20 mA	
Configurable/programmable	no	
Load/output load current output	< 600 $\Omega$ (at I = 20 mA output signal)	
Supply		
Supply voltage range	9.6 V DC ... 30 V DC (no separate supply voltage necessary)	
Power consumption	600 mW	
General data		
Limit frequency (3 dB)	100 Hz	
Maximum transmission error	$\leq$ 0.1 % (of final value)	
Additional error, load-dependent	< 0.075 % (of measured value / 100 $\Omega$ load)	
Maximum temperature coefficient	$\leq$ 0.002 %/K (of measured value / 100 $\Omega$ load)	
Electrical isolation	Reinforced insulation in accordance with IEC 61010-1	
Overvoltage category	II	
Mounting position	any	
Degree of pollution	2	
Rated insulation voltage	300 V (effective)	
Test voltage, input/output/supply	3 kV (50 Hz, 1 min.)	
Dimensions W/H/D	6.2 mm / 110.5 mm / 120.5 mm	
Type of housing	PBT gray	
Connection data		
	Screw connection	Push-in connection
Solid conductor cross section with ferrule	0.2 mm <sup>2</sup> ... 1.5 mm <sup>2</sup>	0.14 mm <sup>2</sup> ... 2.5 mm <sup>2</sup>
Solid conductor cross section without ferrule	0.2 mm <sup>2</sup> ... 2.5 mm <sup>2</sup>	0.14 mm <sup>2</sup> ... 2.5 mm <sup>2</sup>
Conductor cross section, flexible	0.2 mm <sup>2</sup> ... 1.5 mm <sup>2</sup>	0.14 mm <sup>2</sup> ... 2.5 mm <sup>2</sup>
Conductor cross section AWG	24 ... 12	24 ... 12
Stripping length	10 mm	10 mm

**Ambient conditions**

Ambient temperature (operation)	-40 °C ... 70 °C
Ambient temperature (storage/transport)	-40 °C ... 85 °C
Permissible humidity (operation)	5 % ... 95 % (non-condensing)
Maximum altitude for use above sea level	< 2000 m

**Conformance with EMC directive**

Noise immunity according to EN 61000-6-2  
 When being exposed to interference, there may be minimal deviations.  
 Noise emission according to EN 61000-6-4

**Conformance/Approvals**

Conformance	CE-compliant
ATEX	⊕ II 3 G Ex nA IIC T4 Gc X
UL, USA/Canada	UL 508 Listed
UL, USA/Canada	Class I, Div. 2, Groups A, B, C, D T6
UL, USA/Canada	Class I, Zone 2, Group IIC T6
Shipbuilding	GL applied for

## 5 Safety regulations and installation notes

### 5.1 Installation notes

- The category 3 device is designed for installation in zone 2 potentially explosive areas. It meets the requirements of EN 60079-0:2012+A11:2013 and EN 60079-15:2010.
- Installation, operation, and maintenance may only be carried out by qualified electricians. Follow the installation instructions as described. When installing and operating the device, the applicable regulations and safety directives (including national safety directives), as well as generally approved technical regulations, must be observed. The safety data is provided in this package slip and on the certificates (conformity assessment, additional approvals where applicable).
- While the devices are in operation, contact-dangerous voltages may be present on the control elements. For this reason parameterization, conductor connection, and opening of the module lid are allowed only when devices are in a de-energized state unless the connected circuits are exclusively SELV or PELV circuits.
- The device must not be opened or modified. Do not repair the device yourself, replace it with an equivalent device. Repairs may only be carried out by the manufacturer. The manufacturer is not liable for damage resulting from violation.
- The IP20 protection (IEC 60529/EN 60529) of the device is intended for use in a clean and dry environment. The device must not be subject to mechanical strain and/or thermal loads, which exceed the limits described.
- The device is not designed for use in atmospheres with a danger of dust explosions.
- The device complies with the EMC regulations for industrial areas (EMC class A). When using the device in residential areas, it may cause radio interference.
- If the device is not used as described in the documentation, the intended protection can be negatively affected.
- To protect the device against mechanical or electrical damage, install it in a suitable housing with appropriate degree of protection as per IEC 60529.
- Provide a switch/circuit breaker close to the device, which is labeled as the disconnecting device for this device.
- Provide for an overcurrent protection device ( $I \leq 4 \text{ A}$ ) in the installation.
- The housing of the device provides basic insulation against the neighboring devices for  $300 \text{ V}_{\text{eff}}$ . If several devices are installed next to each other, this must be taken into account, and additional insulation must be installed if necessary.
- The voltages present at the input, output and supply are extra-low voltages (ELV). Depending on the application, dangerous voltage ( $> 30 \text{ V}$ ) against ground could occur. For this event, safe electrical isolation from the other connections has been implemented.
- The device must be stopped if it is damaged, has been subjected to an impermissible load, stored incorrectly, or if it malfunctions.
- Only use copper connecting cables providing the permitted temperature range ( $60^\circ\text{C}/75^\circ\text{C}$ ).

### 5.2 Installation in Zone 2

- Observe the specified conditions for use in potentially explosive areas! Install the device in a suitable, approved housing that meets the requirements of IEC/EN 60079-15 and has at least IP54 protection. Also observe the requirements of IEC/EN 60079-14.
- Only devices which are designed for operation in Ex zone 2 and are suitable for the conditions at the installation location may be connected to the circuits in the Ex zone.
- In potentially explosive areas, terminals may only be snapped onto or off the DIN rail connector and wires may only be connected or disconnected when the power is switched off.
- The device must be stopped and immediately removed from the Ex area if it is damaged, was subject to an impermissible load, stored incorrectly or if it malfunctions.
- In Ex zone 2, the device may only be operated when all connectors are fully plugged in.



### 5.3 UL Notes

#### **INDUSTRIAL CONTROL EQUIPMENT FOR HAZARDOUS LOCATIONS 45FP**

- 1 Suitable for use in class 1, division 2, groups A, B, C and D hazardous locations, or nonhazardous locations only.
- 2 **WARNING - EXPLOSION HAZARD:** Do not disconnect equipment unless power has been removed or the area is known to be non-hazardous.
- 3 This device is open-type and is required to be installed in an enclosure suitable for the environment and can only be accessed with the use of a tool or key.
- 4 NFC communication and Bluetooth communication must not be used unless the area is known to be non-hazardous.

## 6 Installation

### 6.1 Connection notes



The device contains components that can be damaged or destroyed by electrostatic discharge. When handling the device, observe the necessary safety precautions against electrostatic discharge (ESD) according to EN 61340-5-1 and IEC 61340-5-1.

### 6.2 Structure

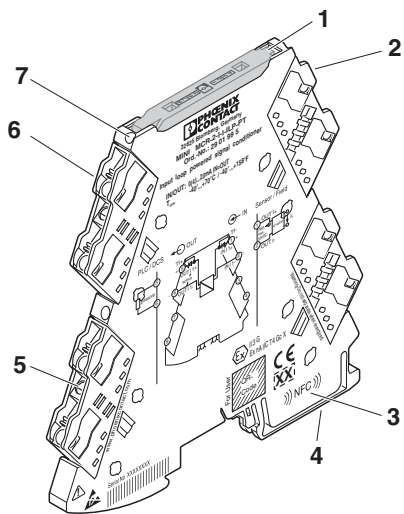

- 1 Cover with labeling option
- 2 Current input
- 3 NFC coil
- 4 Universal snap-on foot for EN DIN rails
- 5 Spindle screw
- 6 Current output
- 7 Current measuring socket

Figure 1 Structure

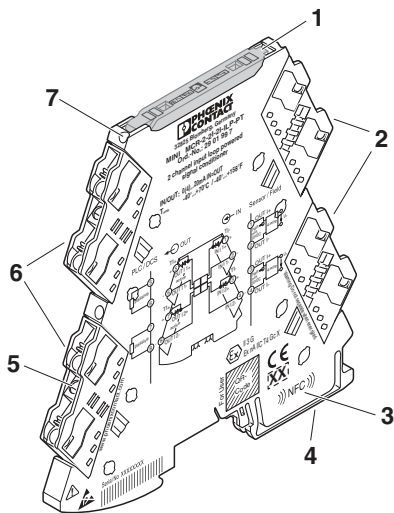

Figure 2 Structure

6.3 Block diagram

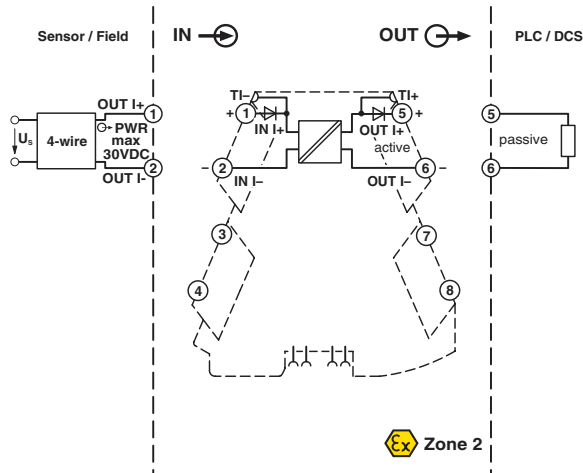

Figure 3 Block diagram

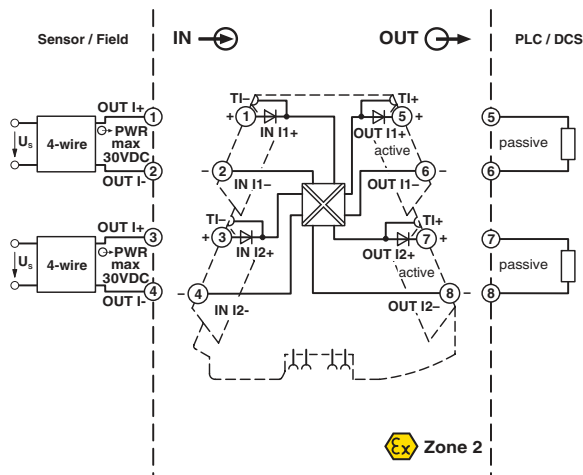

Figure 4 Block diagram

6.4 Assembly

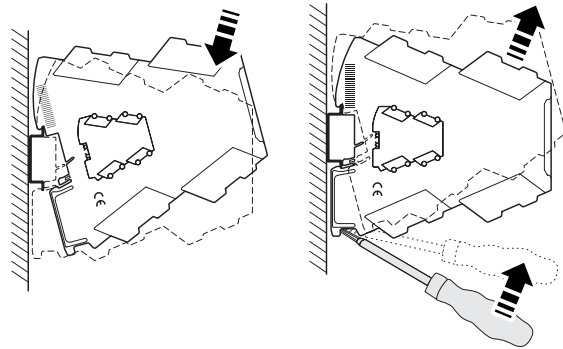

Figure 5 Mounting and removing

- Mount the module on a 35 mm DIN rail according to EN 60715.

An ME 6,2 TBUS-2 DIN rail connector (Order No. 2869728) is used to supply active devices. A DIN rail connector is not required to operate this passive device.

This device can be snapped onto a DIN rail connector – an electrically conductive connection is not established. This means that you do not need to disconnect an existing DIN rail connector element connection.

6.5 FASTCON Pro plugs

The device has pluggable connection terminals with an integrated test disconnect terminal block, with either push-in or screw-in connection technology.

You can plug or screw the FASTCON Pro plugs onto the device directly without tools. You can use the integrated spindle screw to easily remove the plugs from the module or set the isolating position, even when the plugs are connected. For this purpose, use a screwdriver of sufficient width, e.g. SZF 1-0.6x3.5 (order number: 1204517).

The spindle screw will turn by itself when the FASTCON Pro plugs are connected. There is no need for you to fix the spindle screw in place as well.

4-way coding prevents incorrect insertion into the module.

**Screw connection:**

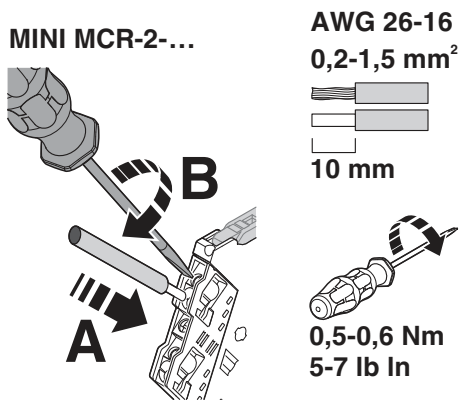

Figure 6 Screw connection

- Insert the wire into the corresponding connection terminal block.
- Use a screwdriver to tighten the screw in the opening above the connection terminal block.

**Push-in connection:**

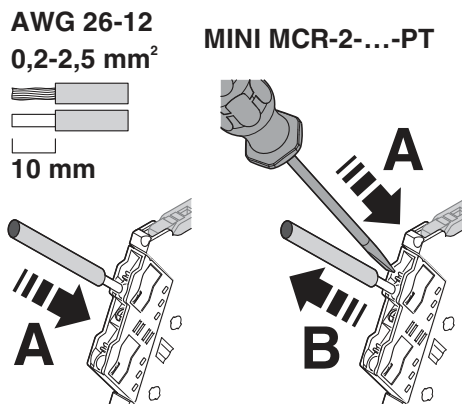

Figure 7 Push-in connection

- Insert the wire into the corresponding connection terminal block.

**6.6 Current measurement**

The device allows current measurement without disconnection of the conductors by means of integrated test disconnect terminals.

Test sockets which support current measurement are marked TI+ or TI-.

For the current measurement, use 2 mm probe tips of the type Fluke TL75-1 or probe tips with a comparable tip shape.

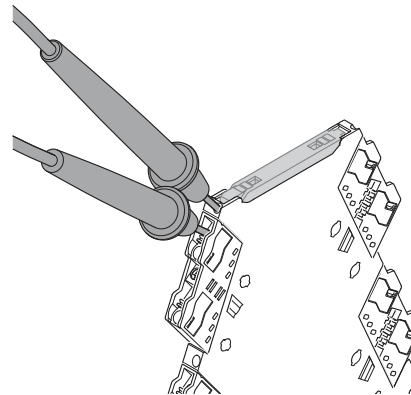

Figure 8 Test disconnect terminal block

Furthermore, individual circuits can be specifically disconnected, e.g. for commissioning.

You can set the isolating position by turning the integrated spindle screw through 180°. The isolating position is indicated by the marking on the plugs.

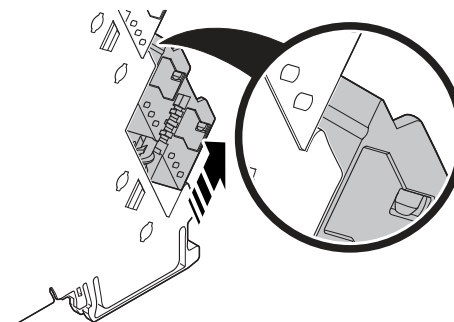

Figure 9 Disconnect position

**6.7 Marking**

Standard UCT-EM... or UC-EMLP tags are available for marking the devices and can be printed as per customer requirements. In addition, the covers provide enough space for the use of freely chosen sticky labels such as SK 5.0 WH:REEL without concealing the LED diagnostic indicators.

## 7 Method of operation

The passive isolator draws the power required for isolation from the input signal.

When using passive isolators, make sure that the current sourcing voltage of the measuring transducer  $U_S$  is sufficient to drive the maximum current of 20 mA via the passive isolator with a voltage drop  $U_V = 3.1$  V and load  $R_B$ .

This means:

$$U_S \geq U_E = 3.1 \text{ V} + 20 \text{ mA} \times R_B$$

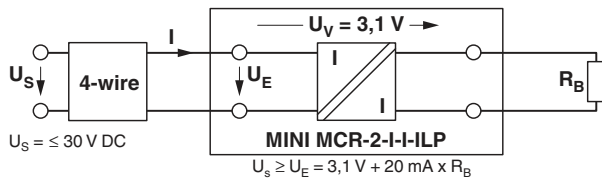

Figure 10 Example application