

1

2

3

4

5

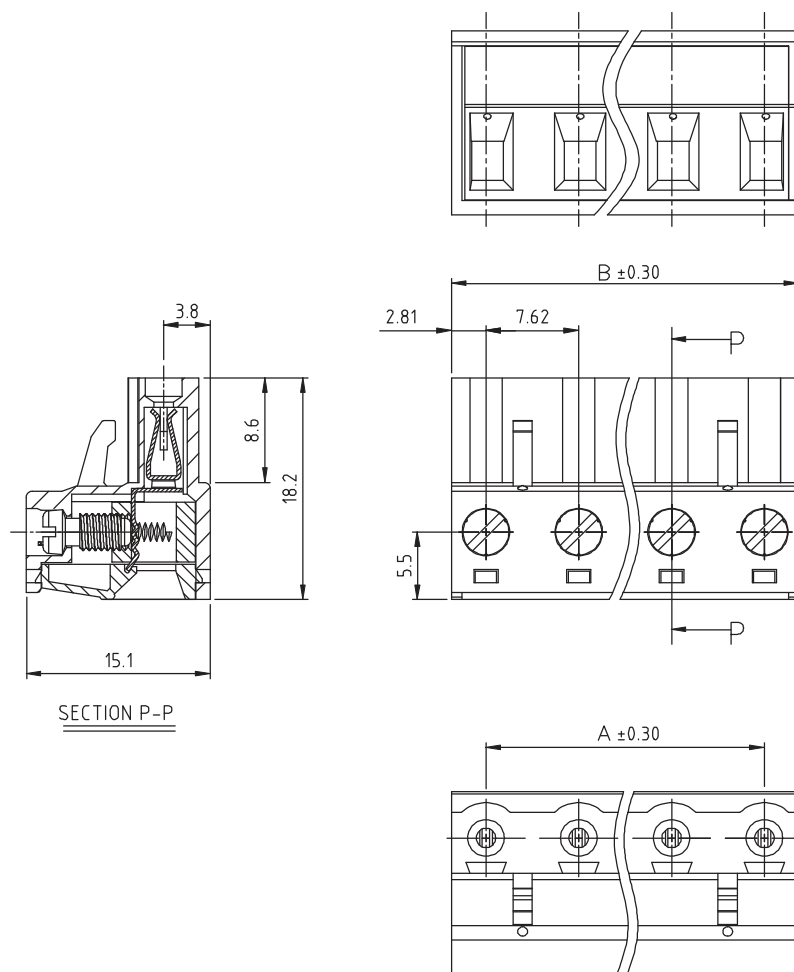

SECTION P-P

TECHNICAL CHARACTERISTICS

MATERIAL
 INSULATOR: PA 66
 FLAMMABILITY RATING: UL94-V0
 COLOR: GREEN
 METAL HOUSING: BRASS (CuZn)
 TERMINAL SCREW: STEEL ZINC PLATING
 TERMINAL SCREW SLOT TYPE: "-"
 WIRE GUARD: PhBz TIN PLATED

ENVIRONMENTAL
 OPERATING TEMPERATURE: -40 UP TO 105°C
 COMPLIANCE: LEAD FREE AND ROHS

ELECTRICAL
 CURRENT RATING: 20 A
 WORKING VOLTAGE: 300 VAC
 WITHSTANDING VOLTAGE: 1.6 KV
 CONTACT RESISTANCE: 20 mOhm max

STANDARD
 cULus CERTIFIED E315414

MECHANICAL
 SOLID WIRE: 24-12 AWG / 0.205-3.31 MM²
 STRANDED WIRE: 24-12 AWG / 0.205-3.31 MM²
 TORQUE: 5.0 Lb-In / 0.56 Nm

WIRE STRIPE LENGTH: 7-8 MM
 SCREW: M3.0
 PITCH: 7.62 MM

PACKAGING
 BOX

DIMENSION
 A = (NB. PINS - 1) x PITCH
 B = (NB. PINS x PITCH) - 2

RoHS Compliant

PROJECTION:



GENERAL TOLERANCE

.X = ± 0.2 .XX = ± 0.15 

APPROVAL: FBr

UNIT: MM

SCALE:

SHEET: 1/2

DRAW: MARVIN

DESCRIPTION: SERIE 3514 - 7.62MM VERTICAL CABLE ENTRY PLUG
 - WR-TBL

WERI PART NO: 691 351 400 0xx

SIZE

A4

G								
F								
E								
D								
C	09-MAY-16	DRAWING	AK					
B	13-OCT-09	STANDARD	JP					
A	05-NOV-08	PDF	JP					
REV	DATE	FILE	BY					

1

2

3

4

5

Cautions and Warnings:

This electronic component is designed and developed with the intention for use in general electronics equipments.



Before incorporating the components into any equipments in the field such as aerospace, aviation, nuclear control, submarine, transportation, (automotive control, train control, ship control), transportation signal, disaster prevention, medical, public information network etc. where higher safety and reliability are especially required or if there is possibility of direct damage or injury to human body, Würth Elektronik must be asked for a written approval.

In addition, even electronic component in general electronic equipments, when used in electrical circuits that require high safety, reliability functions or performance, the sufficient reliability evaluation-check for the safety must be performed before by the user before usage.

A

B

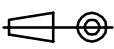
C

RoHS Compliant				PROJECTION: 	GENERAL TOLERANCE .X = +/- 0.2 .XX = +/- 0.15	 WÜRTH ELEKTRONIK	DESCRIPTION: DISCLAIMER	SIZE A4
G								
F								
E								
D								
C				APPROVAL: JC	UNIT: MM	WERI PART NO: DISCLAIMER	SIZE A4	
B					SCALE:			
A	10-SEP-14	PDF	QL		SHEET: 2/2			
REV	DATE	FILE	BY		DRAW: QL			

D