

EdgeReady™ Micro Data Center



Full-Size Floor-Standing, 36U Usable, 10 kVA, 208/240V or 230V

Benefits

- Provides preconfigured IT infrastructure for edge computing servers, storage and network hardware in your most critical applications
- Integrates secure rack space, reliable power distribution, expandable battery backup, remote management and passive cooling
- Prevents configuration errors, reduces installation time, decreases field costs and standardizes edge computing infrastructure
- Ships three business days from receipt of order, after design, assembly and testing by experts in a controlled environment

Included Hardware

- A** SR42UB Premium Rack Enclosure (Standard Width/Depth)
- B** SU10000RT3UG SmartOnline® UPS System with WEBCARDLX Network Management Card
- C** E2MTHDI Environmental Sensor (Temperature/Humidity/Digital Inputs)
- D** (2) PDUMV20HV Metered PDUs with (2) P036-006 Input Cords

Also includes (36) 1U blanking panels with toolless mounting. Assembled/tested unit includes reinforced shock pallet and loading ramps for stable shipment and reshipment with installed IT equipment. Kit version includes major components ready for final assembly on-site.

See Next Page for Customization Options

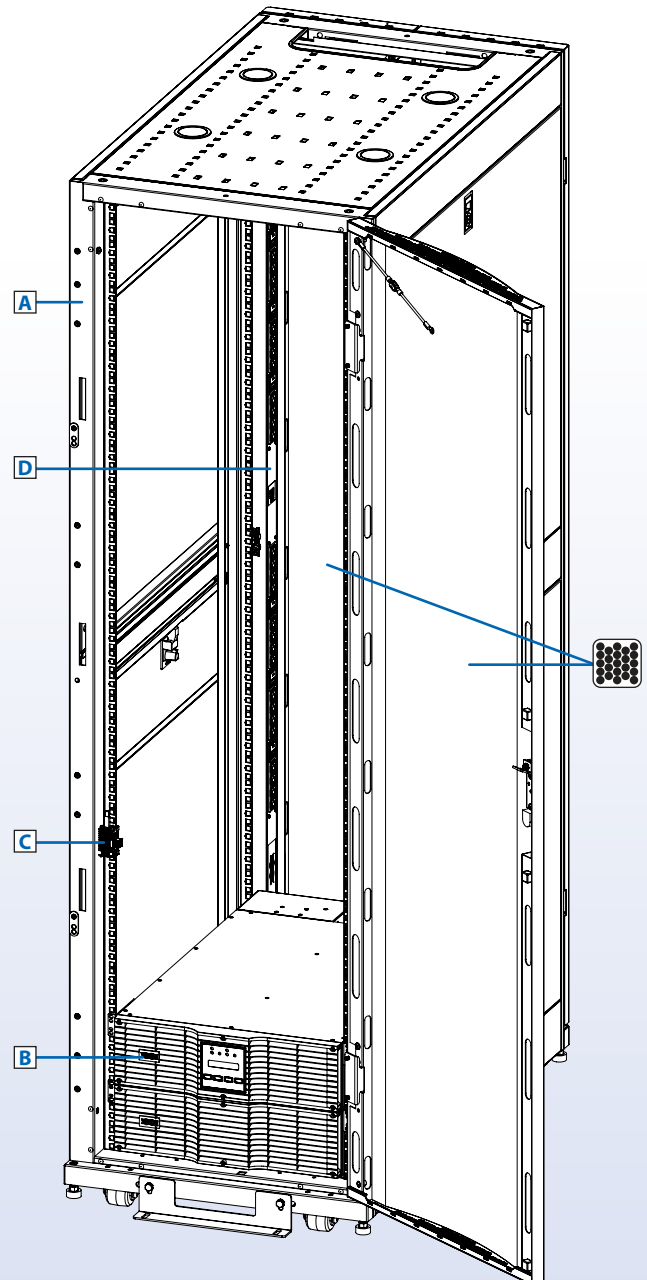

Specifications

Model (Kit)	MDK3F36UPX00000
Model (Assembled/Tested)	MDA3F36UPX00000
Output Power Capacity	10 kVA/9 kW/43.2A Max (208V)
Rack Space	42U Total; 36U Usable
Weight Capacity	3000 lb. (1360 kg) Total; 2484 lb. (1126 kg) Usable
Maximum Device Depth	37 in. (940 mm)
Site Power Requirements	208/240V, 60A or 230V, 63A, 50/60 Hz
Site Outlet Required	Hardwire (208/240V 60A L1-L2-G or 230V 63A L-N-G)
UPS Type	On-Line with Pure Sine Wave Output and Zero Transfer Time
Runtime (50%/100% Load)	12/4.3 min. (Expandable)
High-Availability Features	On-Line (VFI) Operation; Auto Bypass; Battery Backup; Hot-Swappable Batteries; Hot-Swappable Power Module
Usable Outlets (UPS + PDU)	(64) C13, (16) C19
Dimensions (Assembled)	78.5 x 23.63 x 43 in. (1994 x 600 x 1092 mm)
Weight (Assembled)	516 lb. (234 kg)
Warranty*	2-Year Limited Warranty (Extendable)

* Any component with a warranty longer than 2 years will be covered by the longer warranty.



Powering and Connecting Your World

Unlimited Micro Data Center Customization

Tripp Lite's solutions team is standing by to help you tailor your EdgeReady micro data center to match the business and technology requirements of your edge deployment strategy. We ship custom solutions in as little as five business days, assembled and tested. We can help you customize your EdgeReady micro data center in several ways:

- Quick and easy customization via add-on accessories for the stock configurations
- Upgrades to included components of stock configurations with ready-to-ship alternatives
- Customization of individual components like racks, PDUs and cables (increases lead time)

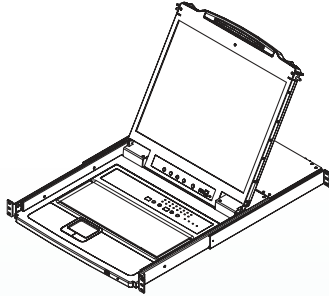

B020-U16-19-IP

1U Rack Console with 16-Port KVM Switch and Remote Access

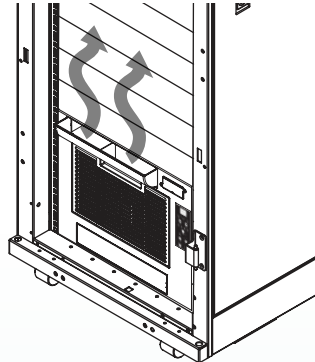

SRCOOL7KRM

8U Rack-Mount Air Conditioning Unit (2 kW)

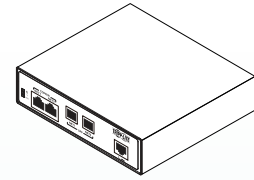

B093-008-2E4U-M

8-Port Console Server with Built-in Modem for Fail-Safe Access



PDUMV20HVNETLX

Vertical Switched PDU with Remote Current Monitoring, Alerts and Outlet Control

Optional Accessories, Sold Separately (Visit tripplite.com to see the full selection.)

Switched PDUs	(2) PDUMV20HVNETLX with (40) C13, (8) C19; 0U (Replace standard PDUs.)
Battery Packs for Extended Runtime (50%/100% Load)	29/12 min. with (2) BP240V10RT3U ; 49/20 min. with (4) BP240V10RT3U
Cooling	SRCOOL7KRM (2 kW; 8U Rack-Mount, NEMA 5-15P) or SRCOOL12K (3.5 kW; Portable; NEMA 5-15P)
KVM Switch	B022-U16-IP ; B020-U16-19-IP (With LCD Console)
Console Server	B093-008-2E4U-M
Door Monitoring Kit	SRSWITCH (Monitors front/rear doors.)
Airflow Management	SR1UBRUSH
Cable Managers	40+ Horizontal, Vertical and External Cable Management Options at tripplite.com
Power Cords	Match to IT Equipment; 250+ Power Cord Options at tripplite.com
Network Cables	Match to IT Equipment; 1000+ Copper and Fiber Network Cable Options at tripplite.com
Patch Panels	60+ Copper and Fiber Patch Panel Options at tripplite.com
Additional Sensors	E2MT (Connect up to 3 sensors total per WEBCARDLX to monitor top/middle/bottom temperature.)

1111 W. 35th Street, Chicago, IL 60609 USA | 773.869.1236 | tripplite.com



Powering and Connecting Your World