

INDUSTRIAL FIBER OPTICS

EXPERIMENTS USING A HELIUM-NEON LASER

*A Reference Manual And Experiment Guide
For Use With Industrial Fiber Optics
Helium-Neon Lasers And Optics Education Sets*

THIRTEENTH EDITION

Based On Instruction Developed By Herbert H. Gottlieb
Physics Teacher; Curriculum Consultant
New York State Department Of Education

© 1973, 1974, 1975, 1976, 1977, 1978, 1979, 1980, 1981, 2000, 2014, 2015

Pn 45-700
[Ref 00-00560]
January 2015

SAFETY NOTES

Lasers create a very special type of light that guarantees exciting laboratory experiments and visual demonstrations for inquiring young minds.

Industrial Fiber Optics (IFO) helium-neon lasers emit a beam of visible orange-red light. They do not emit invisible, exotic, or otherwise harmful radiation.

IFO low power lasers have a light output of only a few thousandths of a watt and shouldn't be confused with the powerful commercial lasers used for burning, cutting and drilling.

Even so, the laser beam must be treated with caution and common sense because it is intense and concentrated. The greatest potential for harm with IFO lasers is to the eyes. No one should look directly into the laser beam or stare at its bright reflections, just as no one should stare at the sun.

The United States Department of Health, Education and Welfare regulates the manufacture of lasers to ensure users are not endangered. The federal government classifies lasers according to their power levels and specifies appropriate safety features for each level. Demonstration lasers fall into Class II and can be identified by a yellow CAUTION label that contains the warning, Do not stare into beam along with a universal laser warning symbol. Class II lasers have a maximum power of 1/1000th of a watt, a power judged to be eye-safe, except possibly in case of deliberate, longterm direct staring into the beam. Safety features include a pilot lamp that glows when the electrical power is ON and a mechanical beam-stop that blocks the beam when power is on. In addition, IFO observes safety directives issued by the European Standards Committee for optical and electrical safety, including directives 89/336/EEC and 92/59/EEC for lasers and EN 71-1 for optics kits.

Laser Safety

1. Instruct students not to look into the laser or stare at bright mirror-like reflections of the beam.
2. Remove all bright mirror-like objects from the work area, including rings, watches, metal bands and tools. Beam reflections can be nearly as intense as the original beam.
3. Block off the beam at a point beyond the farthest point of interest. Use a dull, non-reflective object, such as a piece of wood.
4. If the beam must travel a long distance, keep it directed close to the ground or overhead so it does not cross walkways at eye level.
5. Never use magnifiers such as binoculars or telescopes to look at the beam as it travels or when it strikes a surface
6. Never allow unauthorized people to handle lasers; store them in a safe place away from unauthorized users.
7. Lasers are not toys, use them only for educational purposes.
8. Never point a laser at anyone, no matter how far away.
9. Make sure the laser is always secured on a solid foundation. Keep power cords and adapters away from areas where they can be accidentally disturbed.
10. Helium-neon lasers employ high voltages. The power supply retains potentially harmful voltage for periods after the input power has ceased. Never open the housing and expose anyone to these voltages.
11. Keep these safety regulations near the laser, and read and refer to them in case of safety questions.
12. If you have any other safety questions, please contact Industrial Fiber Optics at (480) 804-1227 or INFO@i-fiberoptics.com.

General Safety

1. Since optics kits contain glass pieces, it is important to remember that they can present a cutting hazard. Please handle them carefully and make sure that you don't contact any edges that might cut you.
2. To fully utilize this manual and its safety warnings, we recommend that the manual be kept close to the optics lab.

Electrical Safety

If the laser housing is opened, IFO's warranty is void.

Each laser is equipped with a UL-approved line cord and 3-prong grounded plug. ALWAYS PLUG THE LASER INTO A GROUNDED OUTLET.

For further information about laser safety and the federal regulations involved, contact the Compliance Officer at the Bureau of Radiological Health, Public Health Service, Food & Drug Administration, Rockville, MD 20857. Telephone: [301] 443-4874. Ask for Regulation Publication HHS PUB FDA 80-80356.

TABLE OF CONTENTS

Safety Notes.....	2
Introduction.....	4
Equipment Included in the Optics Education Kit.....	5
Hints on Using Accessories for Experiments.....	10
What is a Laser?.....	12
Theory of IFO HeNe Laser Operation.....	17
Experiment 1. Color	20
Experiment 2. Ophthalmology.....	22
Experiment 3. Polarization Effects.....	23
Experiment 4. Measuring the Index of Refraction of Glass	24
Experiment 5. Index of Refraction of a Prism	25
Experiment 6. Beam Divergence and Convergence by Lenses	26
Experiment 7. Foucault Knife-Edge Test.....	27
Experiment 8. Knife-edge and Single Slit Diffraction.....	28
Experiment 9. Double Slit Diffraction	29
Experiment 10. Multiple Slit Diffraction Using Gratings.....	30
Experiment 11. Interference by Multiple Internal Reflections in Glass	31
Experiment 12. Lloyd's Mirror	32
Experiment 13. Michelson Interferometer (Elementary Form).....	34
Experiment 14. Thin Film in Interference Using an Air Wedge.....	36
Experiment 15. Diffraction from Small Holes.....	37
Experiment 16. Observing Holograms	38
Experiment 17. Spatial Filtering	39
Experiment 18. Diffraction Patterns from a Ruler.....	40
Experiment 19. Measuring the Curvature of the Earth.....	41
<i>Experiments that can be performed in their entirety with the addition of an IFO 45-610 Optional Accessories Kit.</i>	
Experiment 20. Beam Intensity	43
Experiment 21. Divergence of a Laser Beam.....	44
Experiment 22. Laser Scanning.....	45
Experiment 23. Light Pipes and Fiber Optics.....	47
Experiment 24. The Colors in a Rainbow	48
Experiment 25. Reflection.....	50
Experiment 26. Measuring the Critical Angle	51
Experiment 27. Measuring the Index of Refraction of Liquids	52
Experiment 28. Diffraction Technique for Measuring Index of Refraction	53
Experiment 29. Doppler Effect	54
<i>Additional Experiments for Advanced Study</i>	
Experiment 30. Scattering of Light	56
Experiment 31. Measuring the Index of Refraction of a Gas	57
Experiment 32. Amplification of Movement	59
Experiment 33. Alignment.....	60
Experiment 34. Measuring the Speed of Light.....	62
Additional Industrial Fiber Optics Education Kits & Other Products	65
Cleaning Instructions	68

INTRODUCTION

Thank you for selecting this Industrial Fiber Optics science education kit. The kit builds on an earlier edition developed by Metrologic, Inc., and acquired by Industrial Fiber Optics. The newer version incorporates technology updates that offer cutting edge content for today's young experimenters and scientists of the future.

This manual contains experiments that have been developed by active teachers and thoroughly tested in the classroom. The experiments may be performed using mirrors, lenses, filters and other items already found in schools.

Information about Industrial Fiber Optics' other educational laser and fiber optics kits and a full array of complementary and replacement products can be found at the end of this manual.

EQUIPMENT INCLUDED IN THE OPTICS EDUCATION KIT

Industrial Fiber Optics' Laser Optics Kit (45-600) contains the basic optical components to perform most of the experiments in this manual. The Laser Optics Kit features magnetic holders called "Maggie" Mounts. These mounts permit fast experimental set-ups that are readily adjusted and aligned, yet retain their positions once in place. The catalog number of each item is listed in the table below. To help identify lenses and other optical components in the kit, approximate dimensions and focal lengths are provided here. Exact characteristics for any item must be determined by experiment.

Optical Table and Component Holders

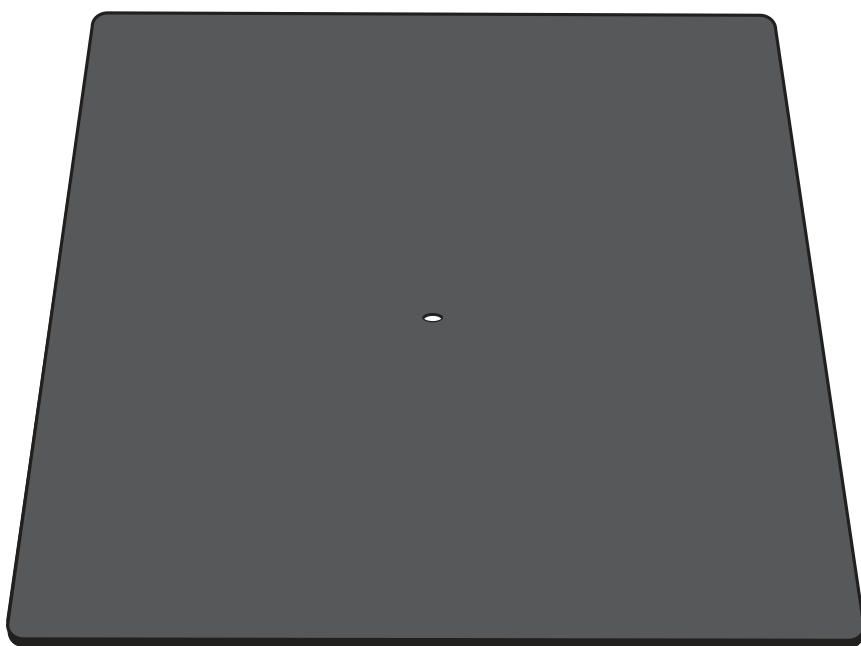

1540.eps

Optical Platform

This 30 x 20 x 0.2 cm steel platform provides a work surface that holds the magnetic component holders securely. A center hole in the platform allows it to be bolted to a 60155 Blank Carrier (not included) if the user decides to mount the platform on the IFO triangular optics bench system.

No. 45-648 Qty. 1

U-Shaped Carrier

This is a tall carrier with two vertical posts about 3 cm apart and a magnetic base. Its steel surface allows other components to be attached magnetically.

No. 45-649
Qty. 4

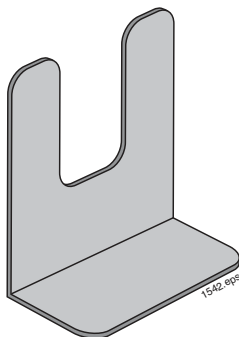

1542.eps

L-Shaped Carrier

A short carrier with a magnetic base. It is most often used in conjunction with the U-shaped carrier to provide x-y-z axis movement for positioning optics.

No. 45-650
Qty. 2

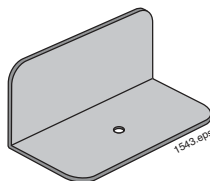

1543.eps

Experiments Book

This laboratory manual contains instructions for performing experiments using IFO helium-neon lasers. The manual also explains safety, the theory of laser operation and how lasers are made.

No. 45-700 Qty. 1

Magnetic Strips

These 15cm long strips have an adhesive backing. They can be cut with scissors and attached to filters, mirrors, glass prism, etc. so these objects can be held magnetically on the carriers below.

No. 45-660 Qty. 2

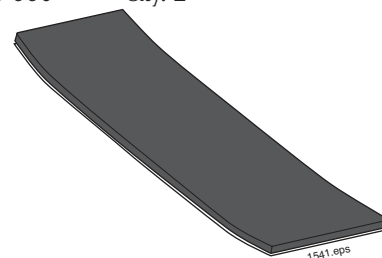

1541.eps

Lenses and Mirrors

Small Plano-Convex Lens on a Circular Magnetic Mount

This lens expands the beam for viewing holograms and for experiments where a wide beam is desired. When the optic mount adapter (below) is used, the magnet allows the lens to be attached directly to the laser. This lens has a focal length of approximately +7 mm.

No. 45-632 Qty. 1



1544.eps

Beam Spreader Lens on a Circular Magnetic Mount

A cylindrical lens that spreads the beam into a thin line for geometric optics experiments and index of refraction investigations. When an optics mount adapter is used, the lens may be attached directly to the laser.



No. 45-657 Qty. 1

Short Focal Length Converging Lens Plate

A lens mounted on a 6 cm steel square. When magnetic tape is attached to the steel plate, it can be mounted on a U-shaped carrier. Focal length (+40 mm or less) is marked on carrier.

No. 45-652 Qty. 1

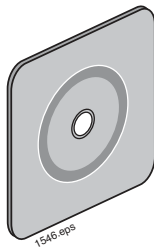

Long Focal Length Converging Lens

This lens has a longer focal length than the 45-652 lens. The focal length (+70mm or greater) is marked on the carrier.

No. 45-654 Qty. 1

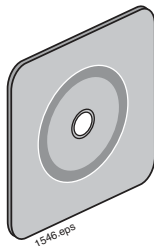

Thin Square Mirror

These are very small, 1 cm square, low mass mirrors (set of two). They can be attached to vibrating objects to reflect the beam. The mirrors are useful for constructing optical amplifiers for magnifying small movements.

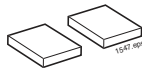

No. 45-669 Qty. 1 (set of two)

Front Surface Mirror

Two 25 x 38 mm mirrors with an aluminized front surface coating. The mirror side (not the glass side) should face the beam. Apply magnetic tape to the glass side. (Cleaning, if necessary, should be done by holding the mirror side downward in a bowl of alcohol and swirling it in a circular motion. Do not wipe or touch the mirror surface.)

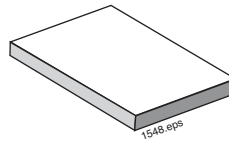

No. 45-646 Qty. 2

Optical Elements

Triangular Prism

The prism permits the study of beam deviation as a function of angle of incidence and shows that monochromatic laser light cannot be dispersed into a spectrum as white light can.

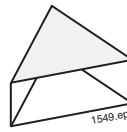

No. 45-726 Qty. 1

Beam Splitter and Rectangular Prism

This 25 x 38 x 6 mm piece of glass divides a rectangular prism beam into two components. Because its long sides have been polished parallel, it can be used as a rectangular prism for observing refraction effects.

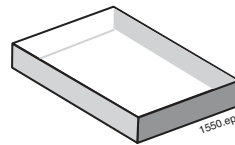

No. 45-728 Qty. 1

Air Film Wedge

Consisting of two pieces of glass hinged together, the 25 x 45 mm air wedge produces dramatic interference patterns due to thin film interference.

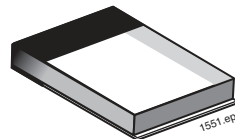

No. 45-661 Qty. 1

Beam Plates

These glass plates are excellent for producing interference patterns. Size is approximately 25 x 75 mm.

No. 45-736 Qty. 1 (set of two)

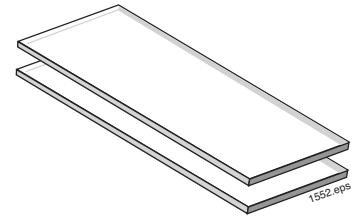

Color Filters

A set of four color filters: blue, green, red and yellow, each individually mounted in a 50 x 50 mm mount.

No. 45-656

Qty. 1 (set of four)

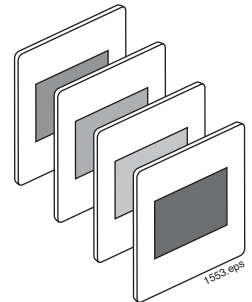

Diffraction Mosaic

Mounted in a 50 mm-square hole, this photoetched film contains three diffraction gratings and four pairs of double slits.

No. 45-658 Qty. 1

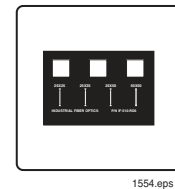

Diffraction Grating

This diffraction grating replica has approximately 530 lines per mm. Mounted in a 50 mm square holder.

No. 45-667 Qty. 1

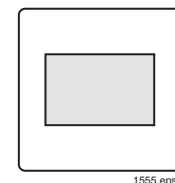

Transmission Hologram

This 50 x 70 mm holographic film has been exposed and developed. When illuminated with laser light and viewed from the proper angle, a three-dimensional view results.

No. 45-624 Qty. 1

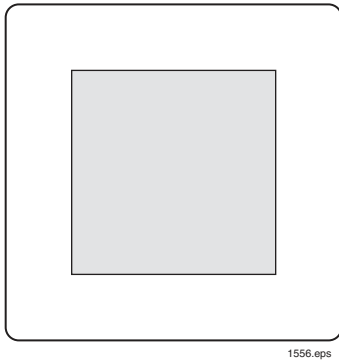

Polarizing Filter

This pair of 50x50mm filters is used for analyzing the polarization of light and for studying polarization effects in laser light output.

No. 45-655

Qty.
(set of two)



Fiber Optics Light Guide

The 2-meter-long glass fiber guides the beam in straight or curved paths by means of internal reflection.

No. 45-747 Qty. 1

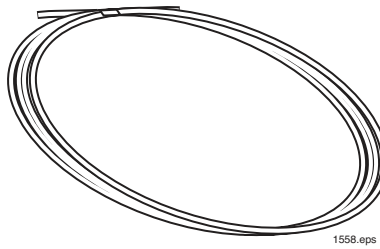

Razor Blades

These blades have sharp well-defined edges that are used to block portions of a laser beam for diffraction experiments.

No. 45-662 Qty. 2

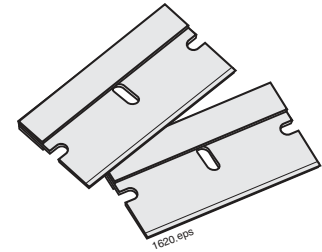

Aluminum Foil and Sewing Needle

These aluminum foil sheets and needle are used to fabricate small pinholes used to clean up a focused laser beam and for diffraction experiments.

No. 45-663 Qty. 10 sheets of aluminum foil

1 sewing needle

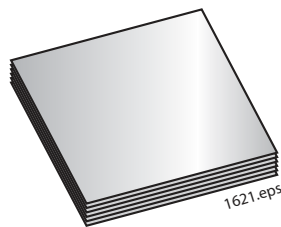

Mechanical Parts

Threaded Steel Cell

With 3/4"-32 TPI threads, the steel cell can be screwed into the optics mount on IFO lasers. Once in place, its steel surface permits magnetic mounting of the 7mm plano-convex lens and the beam spreader lens, both of which are mounted on circular magnets.

No. 45-595 Qty. 1

Ruler

A clear plastic graduated scale used to measure distances between optical components and spaces between interference fringes.

No. 45-322 Qty. 1

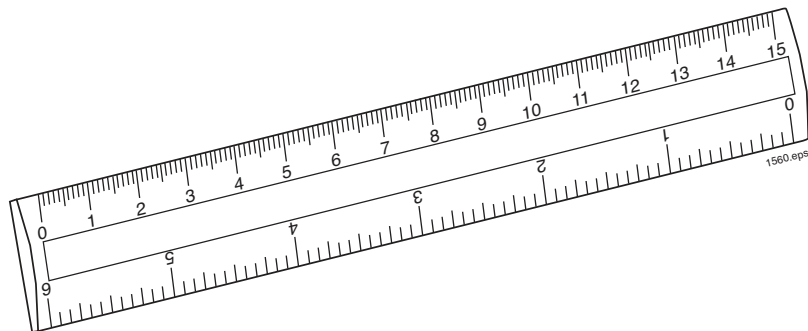

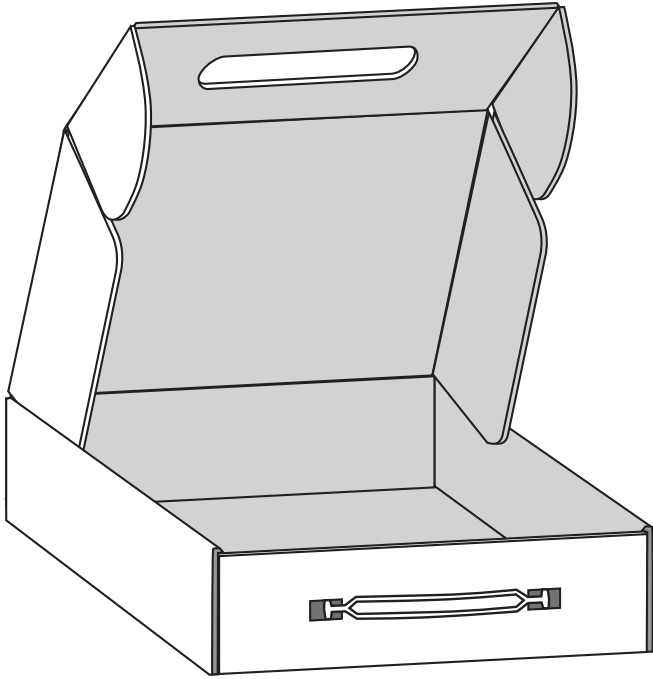

Storage Case and Foam Set

This fitted case holds all of the items in the 45-600 set.

The 3-piece foam set fits inside the storage case to cushion and protect optical components. If re-ordering, please specify foam set for 45-600 Laser Optics Lab.

No. 45-468 Qty. 1

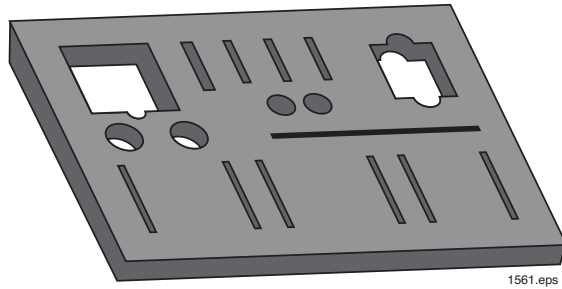

1561.eps

Table 1. Common Abbreviations Used in this Manual

Abbreviation	Long version	Scientific Notation
mW	milliwatts	1×10^{-3} watts
μ W	microwatts	1×10^{-6} watts
nW	nanowatts	1×10^{-9} watts
mm	millimeters	1×10^{-3} meters
μ m	micrometers	1×10^{-6} meters
nm	nanometers	1×10^{-9} meters

Table 2. Metric Prefixes and Their Meanings

Prefix	Symbol	Multiple
tera	T	10^{12} (trillion)
giga	G	10^9 (billion)
mega	M	10^6 (million)
kilo	k	10^3 (thousand)
hecto	h	10^2 (hundred)
deca	da	10^1 (ten)
deci	d	10^{-1} (tenth)
centi	c	10^{-2} (hundredth)
milli	m	10^{-3} (thousandth)
micro	μ	10^{-6} (millionth)
nano	n	10^{-9} (billionth)
pico	p	10^{-12} (trillionth)
fernto	f	10^{-15} (quadrillionth)

HINTS ON USING ACCESSORIES FOR EXPERIMENTS

Overview

While designing new types of lasers and optical components, our engineers first devised makeshift magnetic mountings for their own convenience.

These mounts were effective and saved considerable time in setting up experiments and holding laser optical accessories at correct angles for exploratory work. It was only natural that we make them available to schools and research laboratories as standard catalog items. Engineers dubbed them “Maggie Mounts” and the name stuck.

Maggie mounts are chrome steel. In use, they mount on a heavy flat platform of rigid steel that has been plated black to reduce any unwanted reflections.

Although you will probably discover many new ways to use these mountings in your experiments, here are several helpful suggestions for getting started:

A. Mounting lenses on U-shaped component carriers

Attach lenses so corners of the mount protrude from the top and sides of the carrier. Corners can be grasped to adjust lens position.

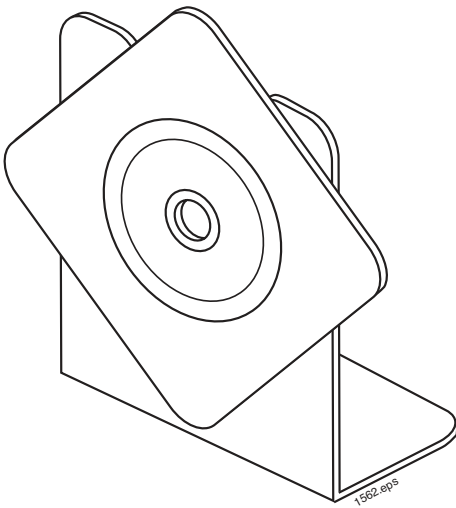

B. Mounting optics components over the laser aperture

The magnetic tape supplied with the kit can be attached to the front of the laser as shown in the illustration. It will hold any of the lenses or beam spreaders in front of the laser aperture without the need for additional component carriers.

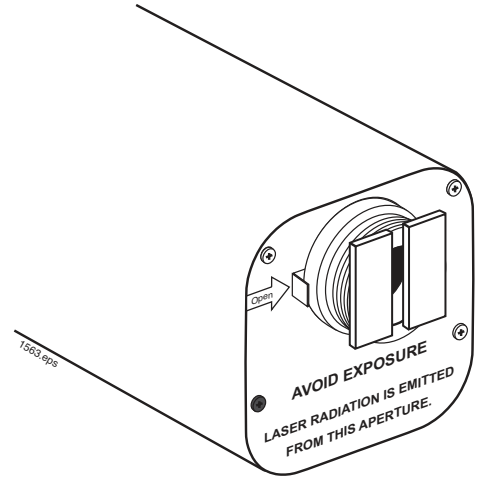

For a more permanent holder use the optional optics accessory mount (part # 45-595) which screws directly into the laser aperture.

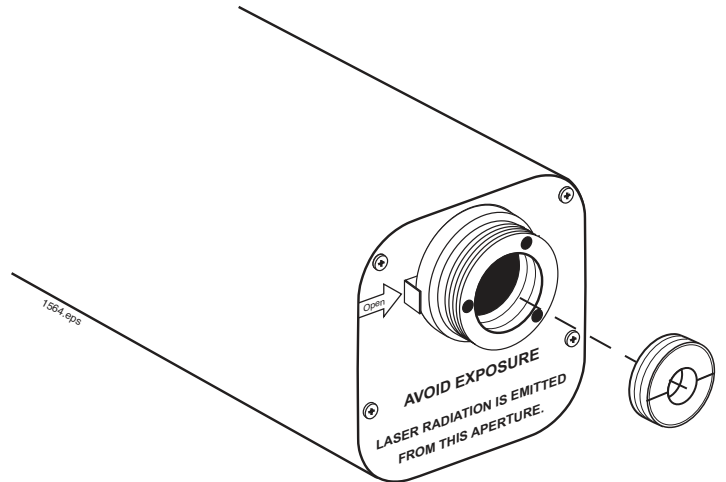

C. Making magnetic mounting for small optics parts

The small optical components furnished with the Optics Education Kit have no factory mountings. They can be held in place with a small amount of the putty included in the kit, or you can easily make your own magnetic mountings by using the adhesive magnetic tape supplied. This tape can be cut with scissors, or scored with a knife and then broken along the score mark. Remove the paper backing from the tape and press the adhesive side against the desired surface. Be careful not to touch or contaminate the adhesive once the protective paper has been removed.

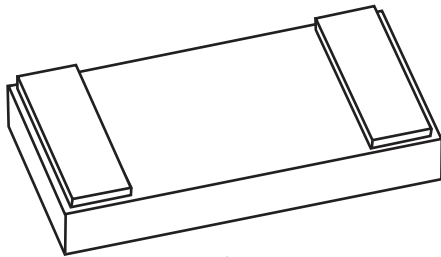

Beam Splitter

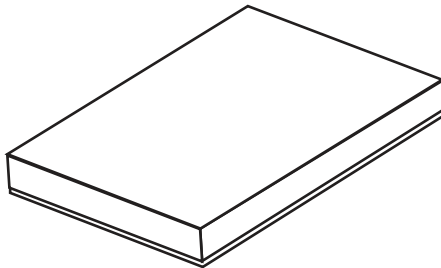

Front surface mirror. Apply tape over entire rear surface.

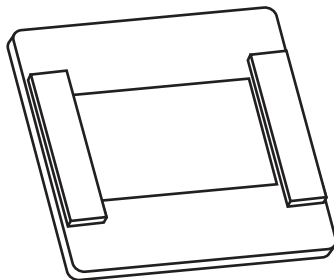

Polaroid and Color Filters, diffraction gratings

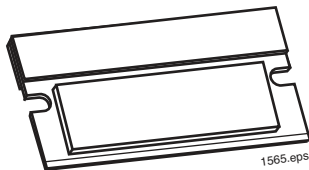

Razor Blade

Examples of Attaching Magnetic Tape to Components

D. Universal Mirror Mount on U-shaped Carrier

Clamp a Maggie Mount L Carrier to a Maggie Mount U-shaped component carrier. Stick the rear of the mirror to the protruding section of the L carrier. To position the mirror along a horizontal plane, rotate the entire carrier on the Maggie Mount platform. Rotate only the L carrier to position the mirror in a vertical plane.

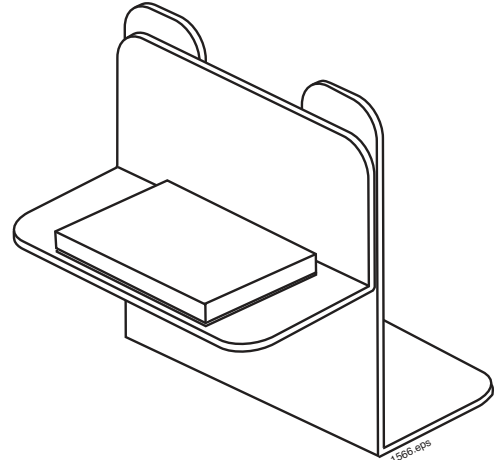

WHAT IS A LASER?

The term “laser” is an acronym. It stands for “Light Amplification by Stimulated Emission of Radiation”. So the laser is a device that produces and amplifies light. Einstein postulated the mechanism by which this is accomplished, stimulated emission, in 1917, but only in the last few decades has it been applied. The light the laser produces is unique, for it is characterized by properties that are very desirable, but almost impossible to achieve by any other means.

To gain a better understanding of what a laser is and what it can do, we will begin with a short review of several phenomena involved in laser action. A good subject to start with is light.

A. Light

Light is a form of electromagnetic energy. It occupies the portion of the electromagnetic spectrum man first dealt with because it was visible to the human eye. Originally, the term “light” included only the visible frequencies. But about 1800, the British-German astronomer W. Herschel placed a thermometer just beyond the blue portion of spectrum produced by a prism using sunlight and found its temperature rose. Later, invisible light was discovered beyond the visible spectrum. Thus frequencies outside the visible range were lumped in with the visible frequencies under the term “light”.

Later, when X-rays, radio waves, and other discoveries were made, light was found to be part of a broad spectrum of electromagnetic radiation. The distinction between the various forms of radiation is primarily energy, which is proportional to frequency. Light is considered to be that portion of the electromagnetic spectrum having wavelengths between 100 and 10,000 nanometers (nm = 10⁻⁹ meters) as shown in Figure 1.

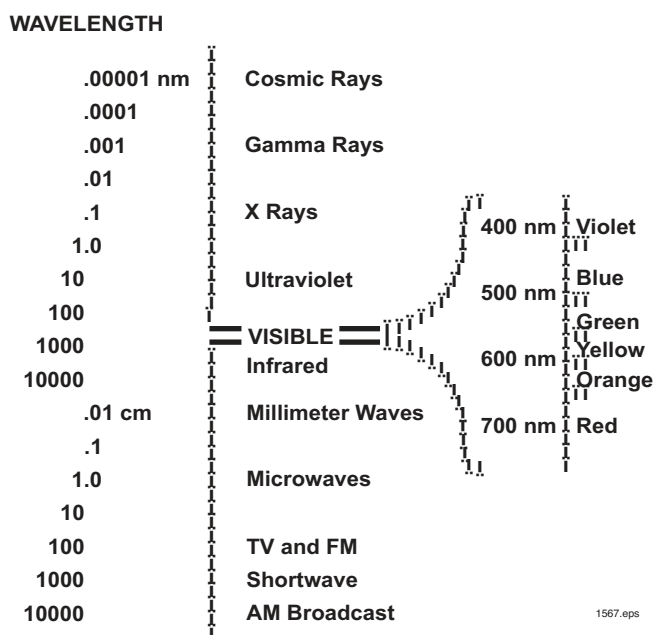

Figure 1. Electromagnetic Spectrum

From a classical point of view, electromagnetic radiation simultaneously displays two seemingly contradictory properties. Electromagnetic radiation:

1. Travels through space as waves; and
2. Has the property of particles with discrete energy and momentum

Grasping each of these properties is important to completely understanding the behavior of all electromagnetic radiation. Both properties also are combined in the current concept of light as described by quantum mechanics.

To aid in visualizing wave behavior, light is often said to move in the same fashion as waves on a body of water. While this is not entirely true, certain characteristics are common to both types of wave motion.

The fact that a specific energy is associated with radiation explains why it is often considered to possess a particulate property. It is sometimes difficult to visualize electromagnetic radiation as a continuous wave, traveling continuously through space. A way to partially relieve this conceptual difficulty is to think of the radiation as consisting of “wave packets” that we call “photons” (see Figure 2). The packet or photon can be visualized as a particle moving through space. This satisfies the human need to “see” the invisible energy and forces that surround us.

*Part of this information excerpted from
BRH Booklet – BRH/SWRHL 70-1*

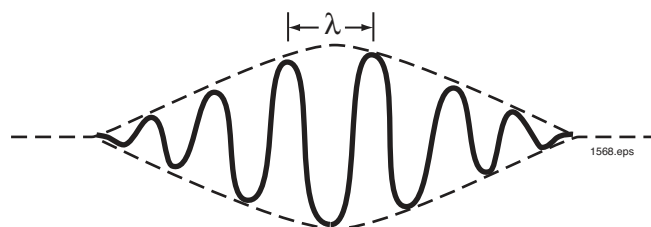

Figure 2. Representation of Photon

B. Electron Energy Levels

Atomic processes can produce light, and these processes are responsible for generating laser light. Let’s look first at atomic energy levels and then see how changes in these levels can lead to the production of laser light.

For purposes of this discussion, we can assume that atoms consist of a small dense nucleus and one or more electrons in orbit about the nucleus.

The relationship between the electrons and the nucleus is described in terms of energy levels. Quantum mechanics predict that these energy levels are discrete. A simplified energy level diagram for a one-electron atom is shown in Figure 3.

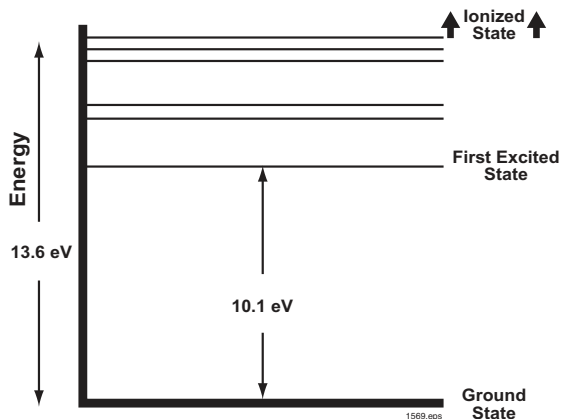

Figure 3. Typical Energy Level Diagram

C. Radiative Transitions

Electrons normally occupy the lowest available energy levels. When this is the case, the atom is said to be in its ground state. However, electrons can occupy higher energy levels, leaving some of the lower levels vacant. Electrons move from one energy level to another by absorbing or emitting energy. One way that an atom can change its energy state is through what is called a radiative transition.

There are three types of radiative transitions. Two of these, absorption and spontaneous emission, are quite familiar. But the third, stimulated emission, is relatively unfamiliar and forms the basis for laser action. Each form of transition is described as follows:

1. *Absorption.* Electrons can absorb energy from a variety of external sources, two of which are highly important. The first of these is a complete transfer of energy from a photon to an orbiting electron. The increase in the energy of the electron causes it to “jump” to a higher energy level; the atom is then said to be in an “excited” state. It is important to note that an electron accepts only the precise amount of energy that will move it from one allowable energy level to another. Hence, only photons of the energy or wavelength acceptable to the electron will be absorbed.

The second means often used to excite electrons is an electrical discharge. In this technique energy is supplied by collisions with other electrons accelerated by the electric field. The result of either type of excitation is that through the absorption of energy, an electron is placed in a higher energy level than it had at rest. The atom that it orbits is also said to be excited.

2. *Spontaneous Emission.* Atomic structures tend to exist in the lowest energy state possible. An excited electron in a higher energy level will therefore attempt to “de-excite” itself in any of several ways. Some of the energy may be converted to heat. Another means of de-excitation is the spontaneous emission of a photon. The photon released by an electron will have a total energy exactly equal to the difference between the excited and lower energy levels. This release of a photon is called spontaneous emission. One example of spontaneous emission (and absorption) can be seen in phosphorescent materials. The atoms are excited by photons of energy from the sun or a man-made light. In dark conditions they de-excite themselves by spontaneously emitting photons of visible light.

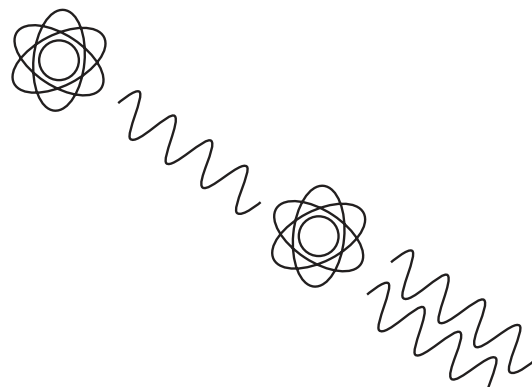

Figure 4. Photon Multiplication by Stimulated Emission

A second example is the common neon sign. Atoms of neon are excited by an electrical discharge through the tube. They de-excite themselves by emitting photons of visible light. Note that in both of these examples electrons may be excited to any one of several energy levels. The photons released in a de-excitation may have any of these frequencies. If enough different frequencies are present in the distribution, the emission may appear to the eye as “white” light.

Let us look at the third, and probably the least familiar type of radiative transition.

3. *Stimulated Emission.* In 1917 Einstein postulated that a photon released from an excited atom could interact with a second similarly excited atom and trigger it to release a photon. The photon released by the second atom would be identical in frequency, energy, direction, and phase with the triggering photon. The original triggering photon would continue on its way, unchanged. Where there was one, now there are two. This is illustrated in Figure 4. These two photons could then proceed to trigger more atoms through stimulated emission.

If a medium such as a gas contains many excited atoms and de-excitation occurs only by spontaneous emission, the light output will be random and approximately equal in all directions as shown in Figure 5A. The process of stimulated emission however can amplify the number of photons traveling in a particular direction. This generates a photon cascade as illustrated in Figure 5B. Placing mirrors at the end of an optical cavity will establish a preferred direction of photon travel. Photons not “normal” (perpendicular) to the mirrors will escape. Thus, the number of photons traveling along the axis of the two mirrors increases greatly and light amplification by stimulated emission of radiation occurs.

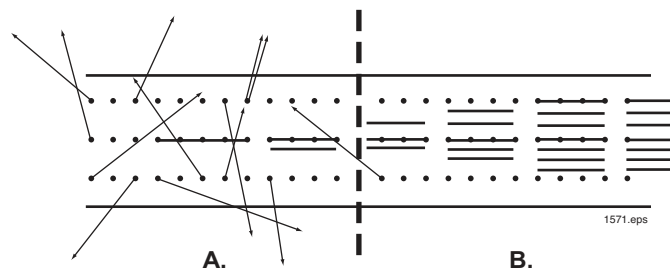

Figure 5. Photon Cascade

D. Population Inversion

The process of stimulated emission will not produce a very efficient amplification of light unless a condition called “population inversion” occurs. If only two of several million atoms are in excited state, the chances of stimulated emission occurring are extremely small. The greater the percentage of atoms in an excited state, the greater the probability of stimulated emission. In the normal state of matter, most electrons reside in the ground or lowest energy levels, leaving the upper levels somewhat depopulated. When electrons are excited and fill these upper levels so more atoms are excited than not excited, the population is considered inverted. This is illustrated in Figure 6.

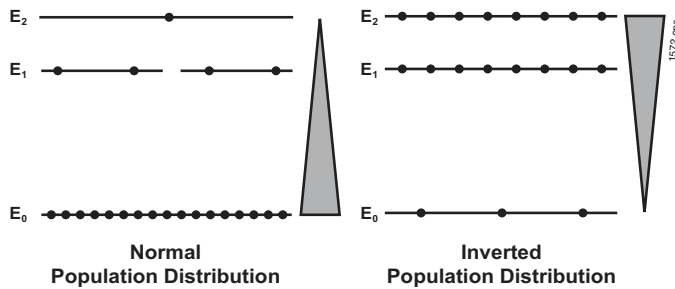

Figure 6. Illustration of Population Inversion

How Does The Laser Operate?

Now that we have discussed some of the phenomena, let’s see how a laser is constructed and how it operates. Three components are necessary: (1) An active lasing medium, (2) An input energy source (called the “pump”), and (3) An optical cavity.

1. *The Lasing Medium.* Lasers can be classified according to the state of their lasing material (“media”). Four common classifications of lasers are presently recognized.
 - A. *Solid State lasers* employ a lasing material distributed in a solid matrix. One example is the ruby laser, which uses a precise amount of chromium impurity distributed uniformly in a rod of crystalline aluminum oxide. The output of the ruby is primarily at a wavelength of 694.3 nm, which is deep red in color.
 - B. *Gas lasers* use a gas or a mixture of gases inside a glass tube. Common gas lasers include the Helium-Neon laser with a primary output of 632.8 nm and the CO₂ laser, with output in the infrared, blue, and green regions. Even water vapor can be made to yield a laser output in the infrared.
 - C. The lasing medium for *Liquid lasers* is usually a complex organic dye dissolved in an organic liquid. The most striking feature of liquid lasers is their “tunability”. Proper choice of the dye and its concentration allows light production at any wavelength in or near the visible spectrum.
 - D. *Semiconductor lasers* consist of two layers of semiconductor material sandwiched together. One material consists of an element with a surplus of electrons, the other with an electron deficit. Two outstanding characteristics of the semiconductor laser are its high efficiency and small size. Typical semiconductor lasers produce light in the blue, red and infrared regions.

2. *Pumping Methods.* Laser action can occur only when a population inversion has been established in the lasing medium. This can be established by pumping energy into the lasing medium. Several pumping methods are commonly used. Optical pumping is employed in solid state and liquid lasers. A bright source of light is focused on the lasing medium. Light photons with the correct energy are absorbed by electrons in the lasing material, making it jump to a higher level. Xenon flashtubes similar to but more powerful than strobe lights used in photography are commonly used as optical pumps for solid state lasers. Liquid lasers are usually pumped by a beam from a solid-state gas laser.

Gas lasers utilize electron collision pumping. An electrical discharge is sent through the gas-filled tube. Electrons in the discharge lose energy through collisions with gas atoms or molecules. Atoms or molecules that receive the energy are excited. Electron collision pumping can be performed continuously to provide a continuous output.

Semiconductor lasers are electrically pumped. An electrical current is passed through the material layers which contain the regions of electron surplus and deficit. When the electrons recombine with the areas containing a deficit or “hole”, spontaneous emission of a photon occurs as the electron drops to a lower energy level.

3. *Optical Cavities.* Once the lasing medium has been pumped to achieve a population inversion lasing action may begin. If no control were placed over the direction of photon movement, photon beams would be produced in all directions. This is called super-radiant lasing.

The direction of beam travel can be controlled by placing the lasing medium in an optical cavity formed by two reflectors or mirrors facing each other along a central axis (Figure 7). Photon beams produced along the cavity axis are reflected 180° at each mirror, and travel once more through the lasing medium causing more stimulated emission. Thus, the beam grows in magnitude with each pass through the lasing medium.

Since the mirrors are not 100 percent reflective, some photons are lost by transmission through the mirrors with each passage back and forth. If pumping is continuous, a state of equilibrium is reached between the number of photons produced by atoms raised to the excited state and the number of photons emitted and lost. This generates a continuous laser output and is usually achieved with low to medium power input levels. Higher power

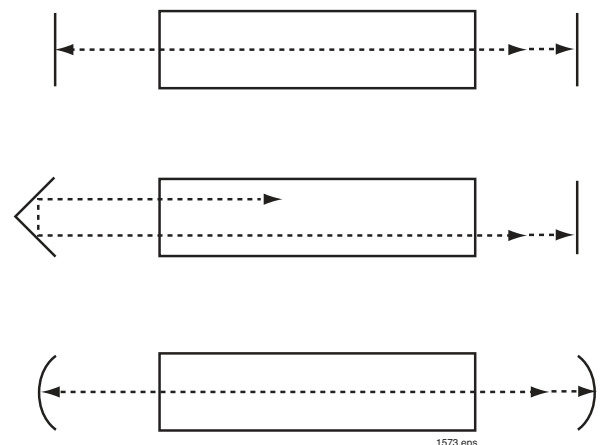

Figure 7. Optical Cavities

inputs are generally produced in the form of a pulse, and the output is also in pulse form. One of the mirrors in the system is usually made more transparent than the other and the output, pulsed or continuous, is sent through that mirror.

Q switching (or Q-spilling) is used to produce an exceptionally high-power output pulse. The term “Q” is derived from the more familiar Q of electrical devices. The Q is a numerical index of the resonant cavity’s ability to store energy at the output frequency. The higher the Q, the more effective the power concentration at the resonant frequency. Q-switching in lasers refers to the method of operation in which power is concentrated into a short burst of coherent radiation. A Q-switch is a device that interrupts the optical cavity for a short time during pumping. A schematic of a Q-switched solid-state laser is shown in Figure 8.

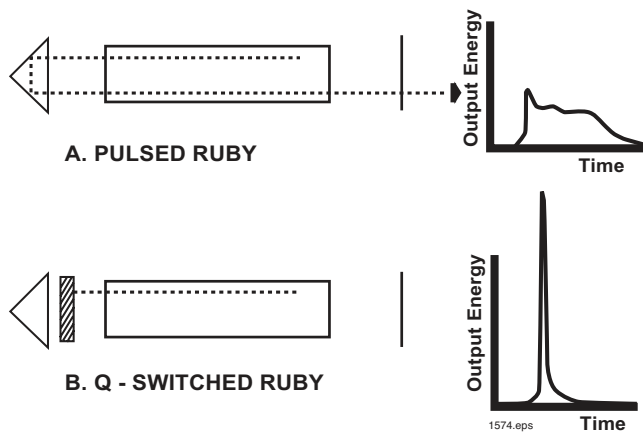

Figure 8. Q-Switch and Pulse Output Diagram

Lasing action normally begins as soon as a population inversion is achieved and continues as long as pumping action maintains the inversion. The Q-switch interrupts the optical cavity and reduces losses due to lasing until pumping can achieve a greater population inversion (say 70% to 80%). The Q-switch then suddenly restores the cavity and the resulting pulse is much shorter and more powerful than would normally be achieved.

One example of a Q-switch is the Pockel’s cell, made of a crystal of ammonium or potassium dihydrogen phosphate (ADP or KDP) sandwiched between two crossed polarizers. In its de-energized state, the crystal will not affect polarized light. But when an electric field is applied across the crystal, the plane of polarization of the incident light is rotated by 90°, allowing it to pass the second crossed polarizer. This completes the optical cavity and results in a giant pulse.

Reflectors can consist of plane mirrors, curved mirrors, or prisms, as shown in Figures 7 and 8. The mirror coating can be silver if laser output power is low, but higher power may require dichroic material. A dichroic material is a crystalline substance in which two preferred states of light polarization are propagated with different velocities, and more importantly, with different absorption. By appropriate choice of material and thickness, the light impinging on the dichroic coating may be either totally absorbed or totally reflected. The first ruby lasers were constructed with the crystal ends polished optically flat and silvered. Semiconductor lasers use a similar technique. Gas

lasers may use mirrors as seals for the ends of the gas tube or may utilize exterior mirrors. In the latter case, the tubes use end windows of glass or quartz set at Brewster’s angle and the output is polarized light.

4. *The Ruby Laser.* The first laser successfully operated was a Ruby Laser, constructed and operated by Dr. T. H. Maiman in 1960. Ruby is a crystal form of aluminum oxide with chromium about 0.05% by weight as an impurity. The chromium gives the ruby its red color and is responsible for the lasing. Chromium exhibits a 3-level energy system, as represented in Figure 9.

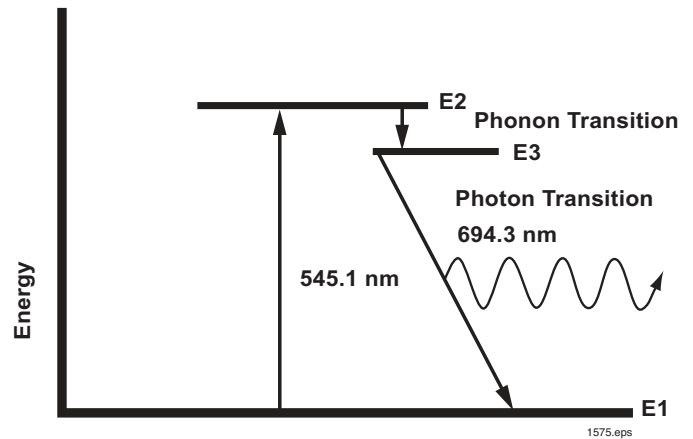

Figure 9. Energy Levels of Chromium

In a ruby laser, the electrons of chromium atoms are pumped to an excited energy level by means of a xenon flashlamp placed beside or around the ruby rod. The chromium electrons absorb photons in a band centered around 545.1 nm and are raised from their ground level to excited level E2. From here, they drop almost immediately to level E3 by means of a phonon (radiation-less) transition. The small amount of energy lost here is through heat and vibration. The electrons will reside in level E3 for a considerable length of time — much less than a second — but for an electron that is relatively long time. Thus, since the flashlamp operates in a period of microseconds, a population inversion can be achieved.

The excited atoms begin to de-excite spontaneously, dropping from level E3 to E1, and since a population inversion is in effect, stimulated emission can begin. In any lasing medium, stimulated emission may occur in all directions, and no particular direction of travel (propagation) is favored. As stated earlier, to gain control of the emission direction and increase the amount of energy within the pulse, the lasing medium is placed inside an optical cavity. Photons not emitted along the axis of the cavity will pass out of the system and be lost. But if a photon cascade is aligned with the cavity axis, it will encounter one of the mirrors and be reflected back upon itself, pass once more through the lasing medium, and then trigger more excited atoms to undergo stimulated emissions. The pulse thus grows in size, and on each encounter, the less reflective mirror part of it emerges from the laser as high intensity coherent light.

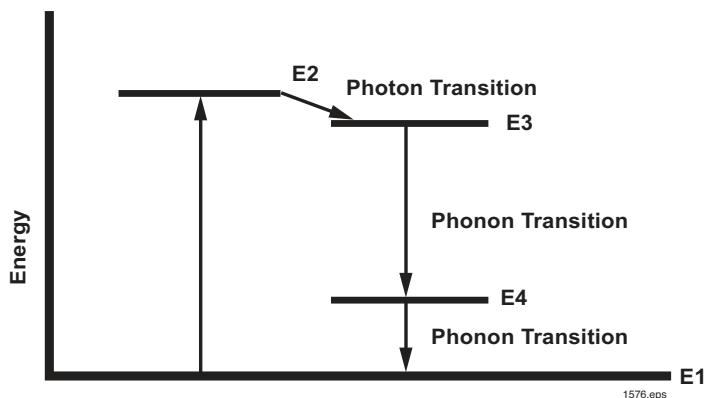

Figure 10. Energy Levels of Neon

The pulse from a typical ruby laser lasts only a few microseconds, since pumping is not continuous. The flashlamp gets its energy from a charge stored in capacitor banks, and once the lamp has flashed, the capacitors must be recharged. Pumping occurs over a few hundred microseconds and continues as long as the flashlamp is discharging.

5. *The HeNe Laser*: The helium-neon laser was developed in 1961 by Ali Javan and proved to be the forerunner of a whole family of gas lasers. Since gas lasers are all quite similar in construction and behavior, we shall discuss the He-Ne laser as representative of the group.

The lasing medium in the He-Ne laser is a mixture of about 85% helium and 15% neon, with neon providing the lasing action. An energy level diagram for neon is shown in Figure 10.

The four-level system of a gas laser differs from the three-level system of chromium in that the emission of a photon does not return the atom to a ground level. Transitions from level E3 to E4 and E4 to E1 are accomplished through phonon transitions in which energy is transferred mainly through heat.

Pumping neon to an excited state is not accomplished directly by the energy source. Rather, indirect pumping is accomplished by exciting atoms of helium, which then transfer energy to the new atoms by way of electron collision. These two gases are picked because they have electron excitation levels that are almost identical, thus facilitating the necessary energy transfer.

Additionally, in the mixture of gases used, a population inversion in helium is not required in order to obtain a population inversion in neon. A more complete energy level scheme for He-Ne is depicted in Figure 11.

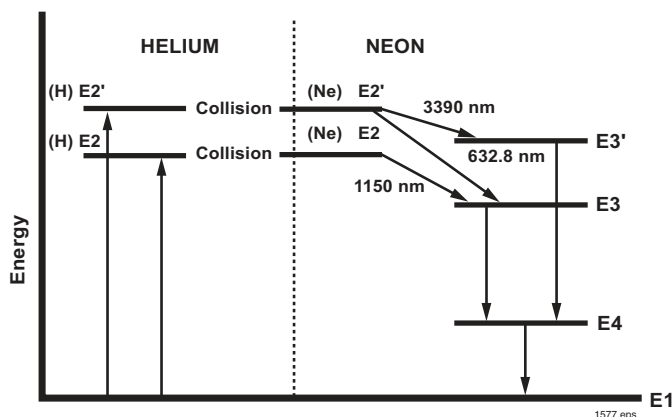

Figure 11. Energy Levels of Gas Laser (Detail)

The HeNe gas mixture is contained in a sealed tube. Excitation of the helium is accomplished by discharging electricity through the tube, similar to a neon sign. The mirrors may be enclosed within the tube or may form the end caps of the tube containing the HeNe mixture. This is a solid geometrical configuration and results in a stable light output.

Some specialized high performance applications require externally mounted mirrors and a delicate alignment procedure. When this is done, the ends of the laser tube are made of Pyrex or quartz set at a Brewster's angle to the axis of the laser, and the output is polarized light.

6. *Other Lasers*. Other lasers operate in similar but more complicated ways. Changes in molecular energy levels may be used rather than changes in electron energy levels, but output is still obtained through the stimulated emission of radiation.

THEORY OF IFO HENE LASER OPERATION

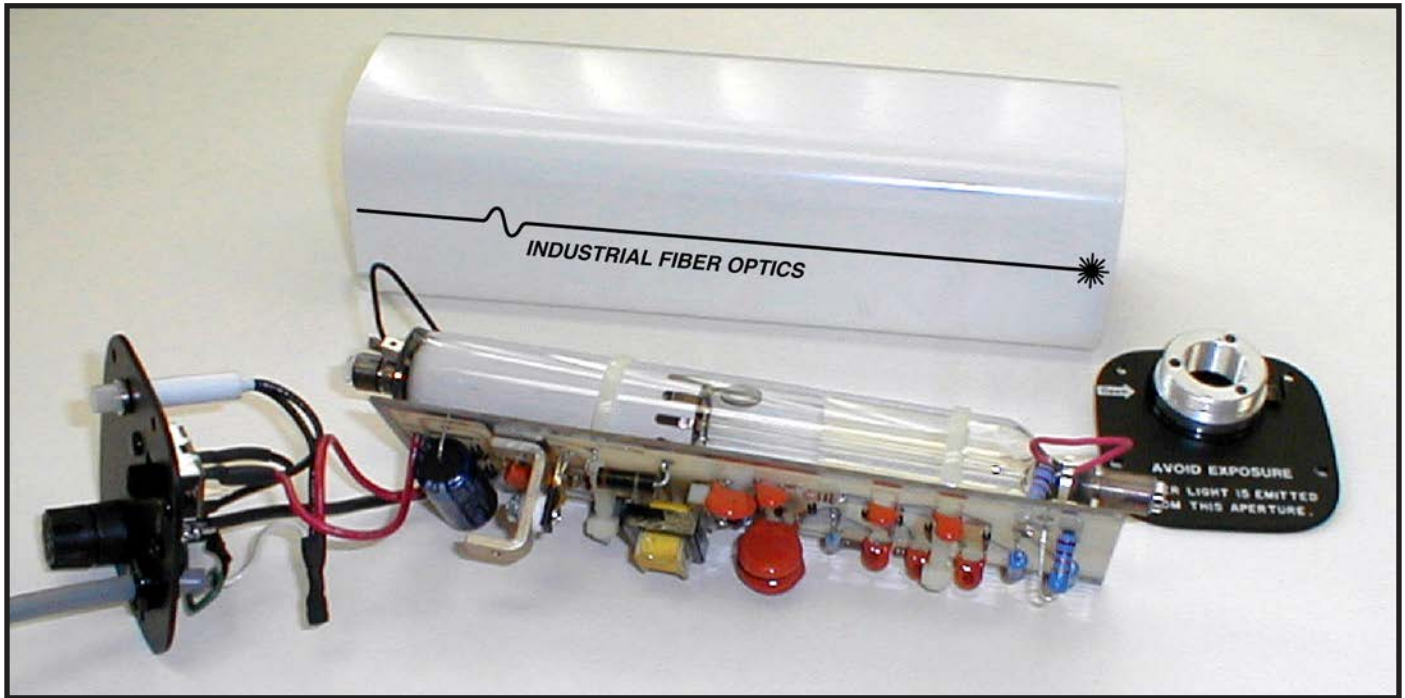

Laser Disassembled to Show Major Components

Low-cost IFO Helium-Neon (HeNe) lasers have been developed specifically for educational purposes. Although it is not necessary to understand the theory of laser operation to perform most of the experiments in this manual, the principles of operation described below are interesting applications of electronics, optics and quantum mechanics.

General Characteristics of Laser Light

Laser light is quite different from most forms of natural light. The key differences are:

1. Brightness - lasers have high energy concentration
2. Monochromaticity - lasers have a single color
3. Collimation - laser beams have narrow divergence
4. Coherence in time and space – laser light travels in synchronized waves.

To understand why these aspects of laser light are different, let's see how a laser works.

General Theory of Operation

The IFO HeNe laser is a long tube (glass or steel) filled with a mixture of helium and neon gases under low pressure. A solid-state power supply converts 110 volts AC into 1,100 volts DC. This high voltage is applied to a set of electrodes in the laser tube setting up a strong electric field. Under the influence of this field, the gases are activated and a beam of intense red light is emitted from the front of the laser. The light is monochromatic with a wavelength of 632.8×10^{-9} m (6328\AA or 632.8 nanometers) and has other characteristics associated with laser light.

The Plasma Tube

The plasma tube consists of a long capillary tube (1mm diameter) surrounded by a hermetically sealed (glass or steel) outer tube. The laser action that produces the beam occurs in the central capillary tube as the high voltage DC is applied to a mixture of gases (approximately 85% helium and 15% neon) that are at a pressure of about 1/300 of an atmosphere. As electric energy is applied, the electrons of each gas atom respond by changing their orbits from the normal ground level configuration to the larger or more complex orbits that are associated with higher energy levels.

After a short time in an energized state, the electrons spontaneously revert to their original ground state conditions, giving off their recently acquired energy as photons of light. They are emitted in many different directions, making the entire laser tube glow with the characteristic blue color of helium and the red color of neon.

Some photons are emitted along the axis of the capillary tube where they encounter other energized atoms. Each such encounter stimulates the gas atoms to produce additional photons that join the original one — like a snowball rolling down a snow-covered hill, growing larger and gaining energy as it travels. The phenomenon is called stimulated emission of radiation. The stimulated emission results in a combined wave of increasing amplitude.

Upon reaching the end of the laser tube, the wave encounters a mirror that sends it back through the tube to stimulate more energized atoms, and increase its amplitude by a factor of 1.02 with each pass. With a flat mirror at each end of the laser tube, perfectly aligned waves of high amplitude are generated in a very short time. The waves are coherent in time because only those with an integral number of half wavelengths from mirror to mirror can sustain oscillation. The situation is similar to the standing waves in a jump rope.

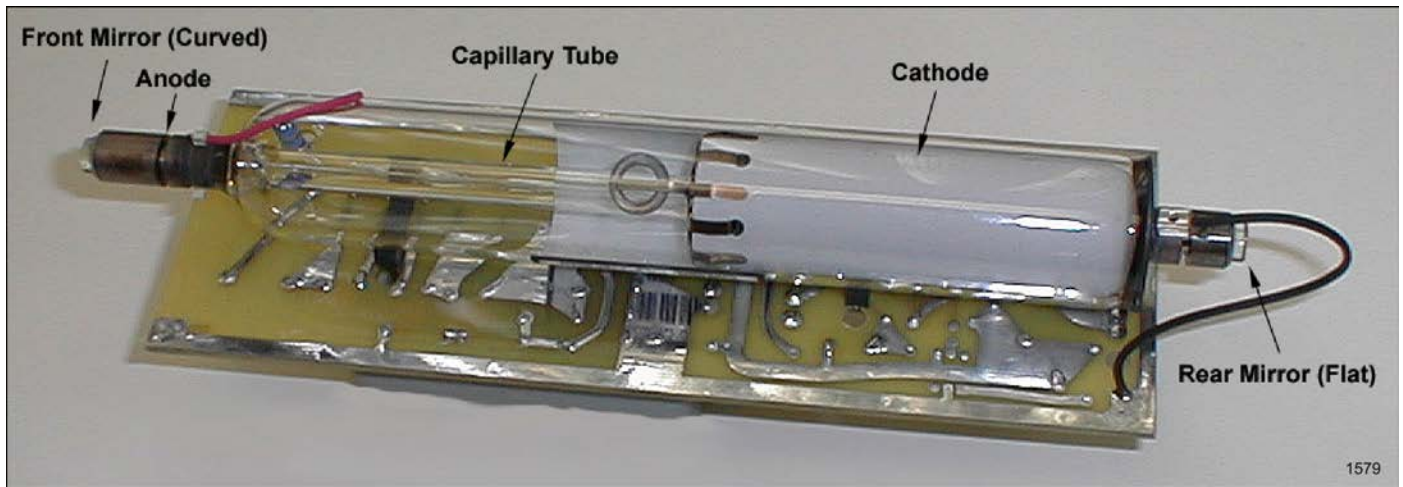

To produce an external laser beam the mirror at the front of the laser tube is a partial reflector, which reflects 99% of the light and transmits approximately 1%. The mirror at the back of the laser tube has a higher reflectivity and reflects about 99.9% of the light while transmitting less than 0.1%.

Neon radiates several different wavelengths of light as its electrons fall from higher energy levels to the ground state. When the orbital electrons fall from the 3s2 to the 2p4 level, they produce some of the strongest radiation in the visible light range (6328Å)

During the manufacturing process, coatings on the two mirrors are carefully adjusted so the laser will resonate at the 6328Å emission, and exclude other radiation produced by the neon gas.

IFO lasers use a “semi-confocal” mirror arrangement. This consists of a flat mirror at the back of the laser tube, and a concave mirror at the front where the beam comes out. Although a greater power output can be achieved with two flat mirrors (or long radius curved mirrors), they are very difficult to align. It’s even more difficult to maintain their alignment when the laser is subjected to minor mechanical stresses during operation. With the semi-confocal arrangement, some power is sacrificed, but the laser is so stable that it can withstand the vibration and stress that occurs in a typical student laboratory. Furthermore, the curvature of the front mirror is calculated to focus the beam at the surface of the distant flat mirror. This curve/flat arrangement produces a laser beam that is cone shaped between the mirrors. The narrow point of the cone is at the flat end, and the wide point is diverging at the curved end. To compensate for this divergence, an additional converging lens surface is placed on the laser output mirror to produce a beam

whose edges are very close to parallel.

The internal geometry of individual laser tubes causes the beam to vibrate more strongly in one particular plane. This non-symmetrical distribution causes the beam to be elliptically polarized. Sometimes a secondary beam is also polarized at right angles to the favored direction of vibration. In a short laser tube the output beam is polarized at any given instant, and then this plane of polarization appears to shift between two favored directions at right angles to each other in an unpredictable fashion. You can observe this interesting effect by passing the laser beam through a polarizing filter to see the changes in beam intensity (# 45-655).

The capillary tube in which the laser action occurs is surrounded by a second tube about one inch in diameter. This outer tube has two purposes:

- 1) It supports the inner capillary tube and the two end mirrors in a rigid permanent alignment.
- 2) It provides a large reservoir of neon gas that replenishes the supply in the laser cavity as it is slowly absorbed by the cathode during laser operation.

Helium gas is included in the laser because it enhances the output of the neon gas by as much as 200 times. As helium atoms are energized by high-voltage direct current, they collide with nearby neon atoms in a very efficient energy transfer process. Although neon gas alone will provide laser action, the output is about 200 times as great when helium and neon are mixed in proportions of about 6 to 1 (i.e. about 85% helium, 15% neon).

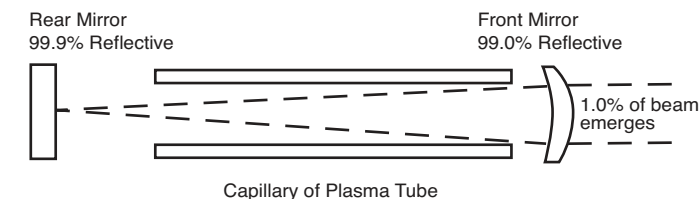

1580.eps

The DC Power Supply

The DC power supply receives 110 volts AC from a standard wall outlet and produces an initial DC voltage of 2000 volts. To do this, a transformer steps up the 110 volts to 630 volts AC. A 630-volt AC signal has peak voltage excursions of about 900 volts positive and 900 volts negative. Solid-state rectifiers act upon the positive and negative excursions of the transformer output separately to produce two independent outputs of 900 volts. These voltages are then added

in series using a voltage multiplier circuit to produce a combined output of approximately 1800 volts. This is reduced to the required 1,100 volts with the aid of a string of ballast resistors. To start the initial laser action and ionize the gas in the tube, a separate circuit provides a pulse of about 2,000 volts that is automatically removed once the laser action starts.

NOTES:

EXPERIMENT 1. COLOR

Wavelength

IFO helium-neon lasers emit orange-red light at a wavelength of 632.8 nanometers (10^{-9} meters). The light is nearly monochromatic — a single color. HeNe lasers can also produce other colors, including orange, yellow, and green.

Procedure

Find a source of white light (which contains all visible colors) — perhaps the sun or an incandescent flashlight. Form a narrow beam by passing the rays between two razor blades, and then direct the beam through a prism. A spectrum of colors will appear. Do the same with a HeNe laser beam. Since the beam has no other component wavelengths except red, the laser light cannot be divided into colors.

Discussion

In practice most lasers are not completely monochromatic. A truly monochromatic laser (a single frequency laser) produces only one wavelength. IFO lasers produce several closely related wavelength frequencies (axial or longitudinal modes) spaced about 500 MHz apart. These axial modes are spaced within a bandwidth roughly 1.5 GHz wide.

Absorption of Light (white light)

Color filters absorb certain wavelengths, while allowing light of other wavelengths to pass relatively unaffected.

Procedure

Hold filters of various colors in front of your eyes and view objects in the room (not laser beams).

Discussion

Notice that objects appear dark or black (absence of light) when their color has been absorbed. During the absorption process, the light energy of the absorbed wavelengths is changed to heat or mechanical energy inside the filter.

Additional Exercises

Try to determine the percentage of blue, green, yellow, orange and red light that passes through various color filters. Compare with the data in the figure at right.

Absorption of Light (laser light)

Certain types of filters strongly absorb the red light from helium-neon lasers.

Procedure

Use a plano-convex lens to spread out the beam of a neon laser to a circle an inch or more in diameter. Hold various color filters in front of your eyes and view the beam. Select a filter that best absorbs the red light of the laser.

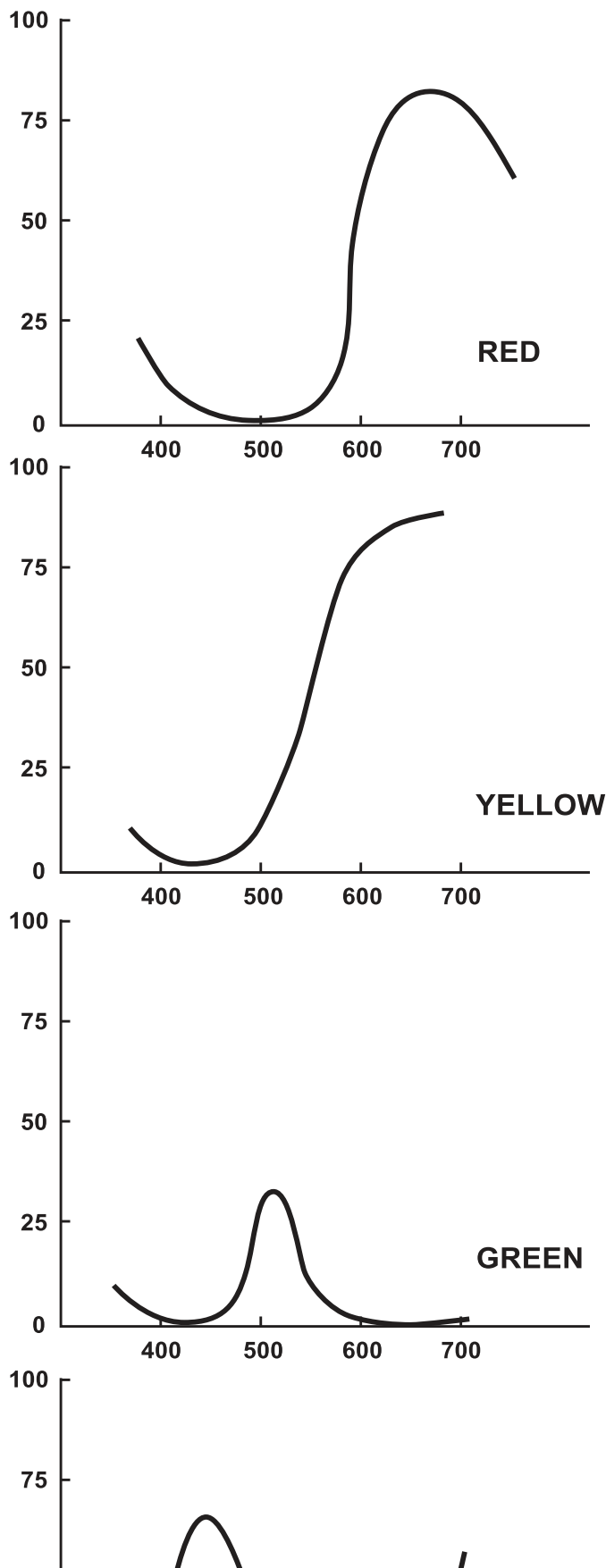

Discussion

Special green filters used on laser safety goggles reduce the observed intensity of helium-neon laser light more than a thousand times.

A green pilot lamp on the laser helps a person wearing laser safety goggles find the ON/OFF switch in very dim lighting. The safety goggles do not absorb the green pilot lamp light. Safety goggles are generally not required for use with visible Class II lasers. The beam has low power and the normal human eye blink reflex provides adequate protection. Lasers at higher power levels (IIIa or above) pose an eye hazard and should be operated with caution and adequate safety procedures.

Coefficient of Absorption

The thicker a filter, the greater its absorption.

Procedure

Find some uniformly colored glass of various thicknesses. Shine a laser beam through each and record the power output using a photometer. On a graph, plot the power output versus the thickness.

Discussion

The power output should vary in an exponential manner using the formula:

$$I = I_0 e^{-k_v x}$$

For details refer to Beer-Lambert Law.

A laser tube is very much like a color filter in reverse. While a green or blue filter greatly attenuates (reduces) the red light of a laser, neon gas inside the laser tube amplifies red light. The entire laser tube is built as a very selective amplifier tuned to red light at the 632.8 nanometers wavelength. Generally, the longer the laser tube, the brighter the beam will be.

Color Signal and Noise

Using inexpensive color filters, it is relatively easy to separate red laser light from other wavelengths of “white” light.

Procedure

Find a color filter that transmits a high percentage of red light, but very little white light.

Discussion

Consider the laser scanners used by supermarket cashiers to decode bar code symbols on merchandise packages. After the scanning beam crosses the symbol, the reflected light must find its way back into the scanner where it can be converted to electrical energy and then into a digital signal for input into a computer. Only a tiny portion of the original laser beam gets back to the photodetector. When it does, it must be clearly separated from room light. Actually, very inexpensive red colorfilters are commonly used. They allow 90% or more of the laser light to pass, while blocking 90% or more of the background white light. To the detector, the red light is bright and the background dark. For more critical applications, narrow bandwidth filters provide an even greater separation of signal and noise.

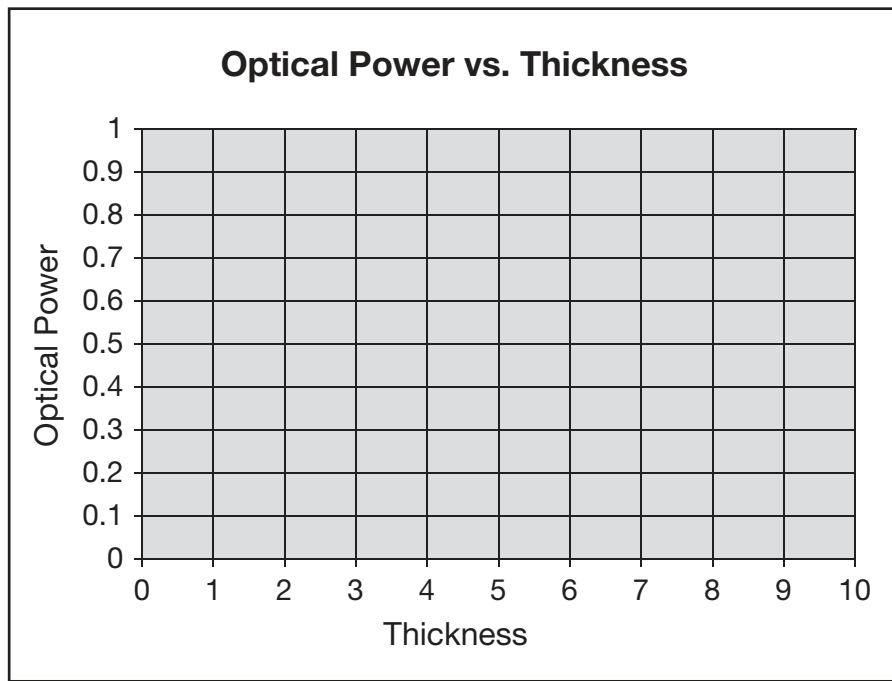

EXPERIMENT 2. OPHTHALMOLOGY

Overview

When an enlarged laser beam is aimed at a wall or at a piece of white paper, the illuminated area appears to have many small spots or grains. This granular appearance is caused by a complex interference pattern produced by the coherent light as the lens of our eye focuses it upon the retina. This phenomenon may be used to diagnose certain eye defects and illustrate how these defects can be corrected with appropriate eyeglasses or contact lenses.

Procedure

- A. In a room with subdued lighting, aim the laser beam at a piece of white paper two or three meters away. Expand the laser beam using the +15 mm lens supplied with the Optics Education Kit.
- B. Observe the illuminated area and notice the many small dots or grains that appear. Move your head very slowly from side to side while observing the spot. If your eyes are normal or you are farsighted, the small spots will appear to move in the same direction as your head. If you are nearsighted, the spots will appear to move in a direction opposite from that of your head movement. In nearsighted persons, the eye tends to focus the pattern a short distance in front of the retina. Therefore, the

parallax caused by the head movement results in an apparent motion of the spots in the opposite direction.

- C. You can demonstrate parallax by holding your fingers apart and placing them a few inches in front of your eyes while looking at an object on a distant wall. When you move your head from side to side while looking at the distant object (which represents the illuminated area), your fingers (which represent the granular interference pattern) will appear to move in the opposite direction.
- D. Simulate myopia (nearsightedness) by holding a long focal length lens in front of your eye (part # 45-654 - focal length 70 mm or greater). Observe the movement of the granulated spots as your head moves from side to side, and then record the results.
- E. Simulate hyperopia (farsightedness) by observing the illuminated area on the wall through the -46 mm lens. Observe the exaggerated movement of the granulations as they move in the same direction as your head from side to side.
- F. If you normally wear eyeglasses or contact lenses, check your eyes in the manner described above with and without the corrective lenses (if convenient), then record your results.

EXPERIMENT 3. POLARIZATION EFFECTS

Polarizing Filters

Polarizing filters have a crystalline structure that allows waves vibrating in line with the crystals to pass, while blocking those vibrating perpendicular to the crystal structure.

Polarization (white light)

All waves, including light waves, possess one of two different types of motion. Sound waves are compressional motion (like compressing, then releasing a spring). Light waves, however, are transverse. To visualize transverse waves, imagine holding one end of a 10-foot-long rope in one hand. The other end of the rope is fastened to a wall, and you are pulling it tight, so it extends in a horizontal line. Now move that hand up/down, right/left and circular in random patterns. With these motions you are creating a visual model of a transverse light wave. Energy, or light, begins at your hand and ends up at the wall. All energy or waves that you created in the rope are unpolarized because there is no defined pattern or motion. Sunlight is unpolarized, as is light from most light sources except lasers.

Conversely, a linearly polarized wave travels in a known and non-varying pattern, as if you were to move the rope only up/down. Unpolarized waves can be filtered/transformed into polarized waves if we use special materials with slots or gratings in them. Imagine the rope passing through a grating with only vertical slots, as shown above. The slot prevents sideways motion, but freely allows the vertical components of vibration to pass.

Placing a second vertical grating behind, and aligned with, the first will still allow the vibrations to pass through both sets of slots freely. However, if we turn the second grating to a horizontal position, none of the vertical light/waves exiting the first grating will pass through or be transmitted by the second grating.

Procedure

View an eye safe white light source through a single 50 x 50 mm polarizing filter (# 45-655). An incandescent bulb is a good candidate. Rotate the filter 360° and note any changes in brightness.

Discussion

With a single polarizing filter we notice a slight light loss in all orientations. Optical power meters and the human eye can't detect changes in polarization unless a polarizing element is used. A light source that doesn't restrict which directions the waves vibrate has approximately the same number of waves vibrating in each orientation.

Procedure

Place a second polarizing filter behind the first. Rotate the second filter and note the changes in light intensity.

Discussion

With a single polarizing filter the light intensity was the same in all orientations. After passing through the filter light waves are oriented so their wave crests and troughs are roughly in the same orientation as the crystals of the filter. When we place a second filter behind the first, light will pass if the crystals in both filters are aligned. But if the crystals of the second filter are perpendicular to the first, very little light will pass through.

Laser Polarization Effects

Many lasers exhibit changes in polarization orientation randomly over time.

Procedure

Turn on a laser from a cold start. Place a single polarizing filter in front of the laser and monitor the beam power using a photometer. Keep a record of the power readings every 10 seconds for 20 readings. Are the changes random or regular?

Discussion

Some lasers contain a special optical element called a Brewster window that restricts polarization to one plane. The light output of these lasers is considered linearly polarized. Lasers without a Brewster window emit light with two polarization components always at right angles to each other. Especially during laser warm-up, the power of one component will increase while that of its counterpart will decrease. These changes occur randomly, seconds to minutes apart. The polarization selectivity is determined in large part by the mirror coatings. The changes occur as a direct result of small changes in mirror spacing as the laser tube swells in size while heating up. These distance changes affect the longitudinal modes under the Doppler curve. (Note: if the laser is linearly polarized, no changes will occur. Only the light from ordinary lasers is randomly polarized.)

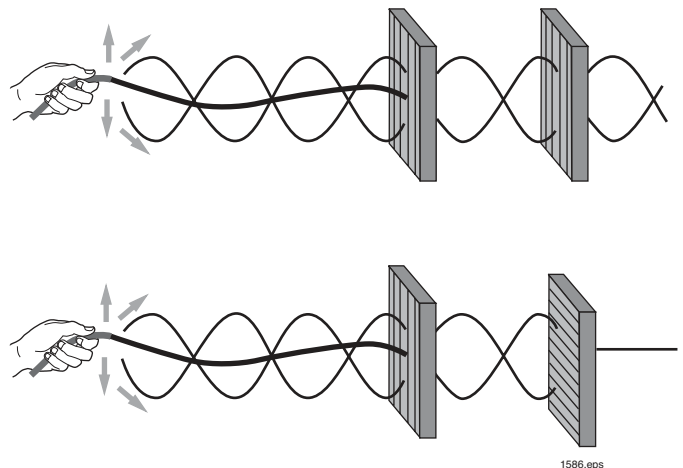

EXPERIMENT 4. MEASURING THE INDEX OF REFRACTION OF GLASS

Overview

When light travels from one transparent medium to another, we usually observe a change of speed at the interface between the two media. This phenomenon also may be demonstrated as a fine laser beam travels from air into glass. If the angle between the laser beam and the glass surface is less than 90° , bending, or refraction, of the light occurs at the point where the speed changes. The amount of bending depends on the angle of entry and the index of refraction of glass, which we will measure in this experiment.

Procedure

- Tape a sheet of graph paper over the surface of a vertical mount. Magnetically attach a rectangular glass prism to the mount. Place the beam spreader over the laser aperture so the laser beam is spread out over both the prism and the face of its mounting panel.
- Rotate the glass so the laser beam enters the edge at an angle of about 30° and emerges from the opposite side.
- On the graph paper behind the glass plate, carefully mark the point where the laser beam enters the glass and the point where it emerges.

- Measure the angle of incidence formed by the incoming laser beam and the normal to the surface of the glass.
- Measure the angle of refraction formed by the refracted beam inside the glass and the normal to the surface.
- Calculate the index of refraction using the Snell's Law relationship:

$$N = \frac{\sin i}{\sin \gamma}$$

- Repeat the procedure above while holding the glass so the angle of incidence changes for each trial. Note the effect on the size of the angle of refraction as the angle of incidence is increased or decreased. For each angle of incidence, calculate the index of refraction of the glass.

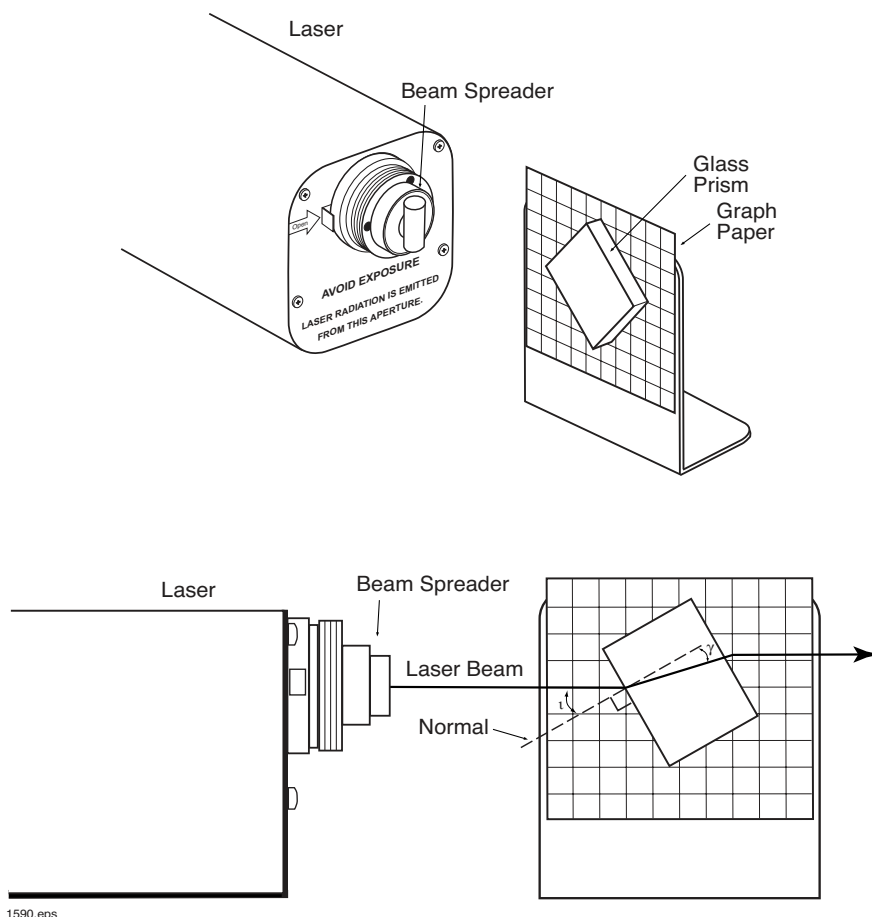

Angles of index and refraction are formed between the laser beam and a normal drawn on paper.

EXPERIMENT 5. INDEX OF REFRACTION OF A PRISM

Overview

When a laser beam passes through a triangular prism, the beam is refracted twice and emerges at an angle that deviates from its original direction of travel. The deviation depends on the laser beam's incident angle, and the prism's index of refraction and apex angle. By rotating the prism, the minimum angle of deviation for the particular prism can be determined. This is where the laser beam angle of incidence equals the exit angle of refraction, causing the minimum deviation from the original direction of travel. Under this condition the calculation for the index of refraction for the prism is greatly simplified. By measuring the apex angle of the prism (A) and the minimum angle of deviation (θ), the index of refraction of the prism may be calculated:

$$n = \frac{\sin 1/2(A + \theta)}{\sin 1/2 A}$$

Procedure

A. Lay the prism (# 45-756) on its side and aim the laser beam into it as shown in the Figure.

B. Prism # 45-726 is an equilateral triangle so the apex angle is 60 degrees. If using a different prism measure and record the apex angle. Slowly rotate the prism while observing the amount of deviation between the emerging laser beam and the original beam direction. Record the value of the minimum angle of deviation that you observed while rotating the prism.

C. Substitute the measured values of the apex angle and the minimum angle of deviation in the formula given above to calculate the index of refraction of the prism.

NOTE: To obtain greater precision in determining the minimum angle of deviation using a laser beam, we suggest the following procedure:

Aim the laser beam across a room and mark the spot where it strikes the wall. Place the triangular prism on its side in front of the laser beam and rotate it slowly while watching the deviation of the beam on the distant wall. Rotate the prism back and forth until the beam deflection from the original direction is at a minimum. Using this long distance technique, we can easily and precisely calculate the magnitude of the minimum angle of deviation by measuring the distances and applying simple trigonometry.

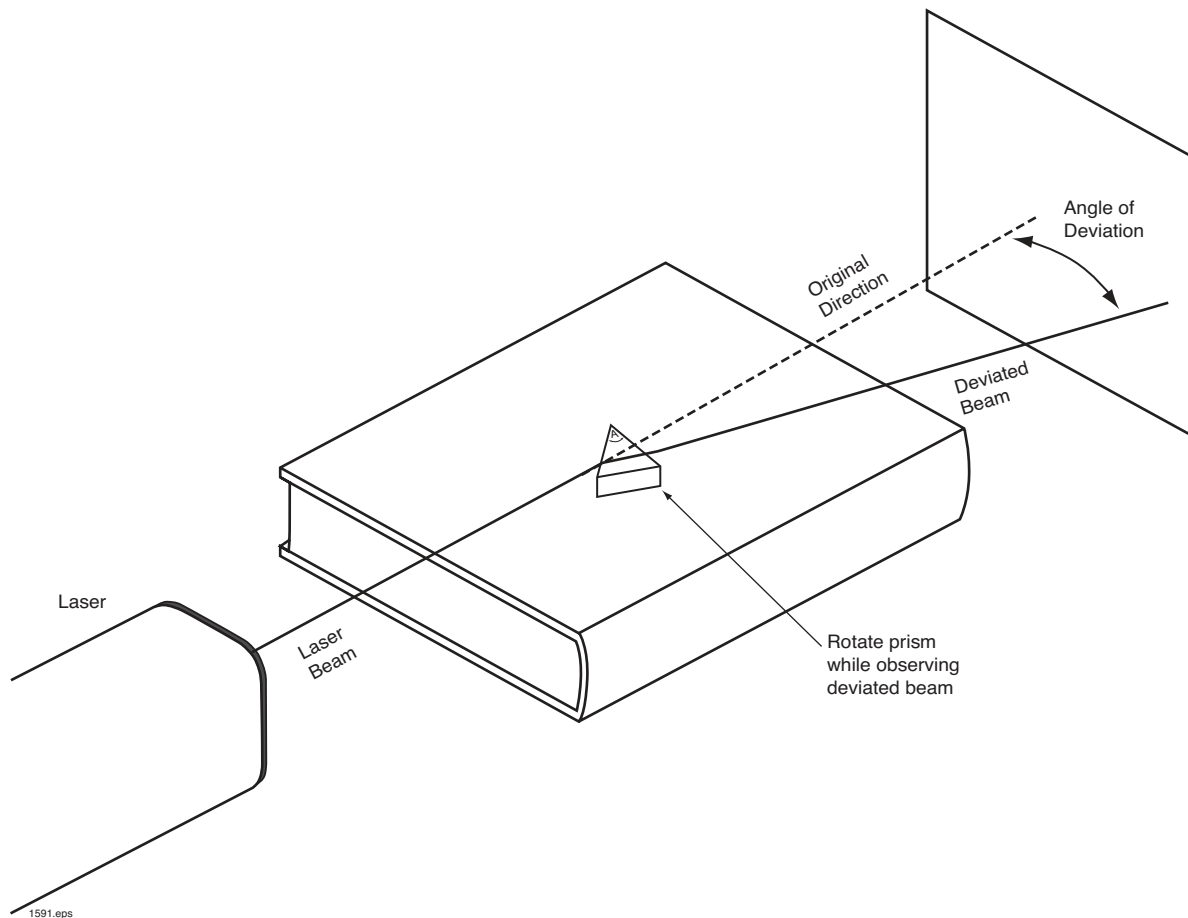

Long distance techniques permit precise determinations of index of refraction using a laser beam.

EXPERIMENT 6. BEAM DIVERGENCE AND CONVERGENCE BY LENSES

Overview

Because a laser beam is so narrow and intense, it may be used with lenses to reproduce most of the textbook diagrams in geometrical optics. In this experiment the characteristics of lenses supplied in the Optics Education Kit will be investigated singly and in various combinations.

Procedure

- A. Mount the plano-convex lens # 45-632 (+7mm) on the vertical Maggie carrier about two centimeters in front of the laser. Hold a piece of graph paper in front of the lens and record the diameter of the laser beam as you move the graph paper away from the lens at intervals of one centimeter. On a graph, plot the beam diameter in relation to its distance from the lens. When the graph values are full, extrapolate additional graph values by extending the line to the left until it reaches the coordinates where the beam diameter is zero. This point is the virtual focus of the plano-convex lens, and the distance between the virtual focus and the lens is the focal length. Compare your measured value for the focal length and the nominal value listed on its mounting card.
- B. Mount the converging lens +80 mm (part # 45-654) on a Maggie mount platform 8 cm in front of the plano-convex lens. Adjust the position of the converging lens by moving it closer to or further from the plano-convex lens until a collimated beam with parallel sides is produced. Check for parallelism of the collimated light by holding a piece of graph paper in the laser beam and moving it away from the lens as far as possible, checking the beam diameter at intervals of one meter. Record the exact positions of the laser, the +7 mm planoconvex lens and the +80 mm converging lens when parallelism of the beam edges has been accomplished. This data will be useful for future experiments where expanded collimated light is required.

- C. Using a beam of expanded collimated light (step B, above) mount a second converging lens +15 mm (part # 45-652) on the optical bench in the laser beam. Hold a piece of graph paper in front of the lens and observe changes in beam diameter as the graph paper is moved away from the lens. Observe that the beam converges to a point and then diverges. The point is the principal focus of the lens and the distance between the lens and the principal focus is its focal length. Measure the focal length of this lens and compare the value you derived with the nominal value listed on the mounting card
- D. The focal length of a compound lens made of two simple lenses can be predicted if we know the focal length of the first lens (f_1), the focal length of the second lens (f_2) and the distance (d) between the two lenses. If known values for these parameters are substituted in the lensmaker's formula, the combined focal length of the two lenses may be predicted using the relationship:

$$\frac{1}{f} = \frac{1}{f_1} + \frac{1}{f_2} - \frac{d}{f_1 f_2}$$

If either of the two lenses is divergent (characterized by a virtual focus), use a negative focal length for this lens when substituting the value in the formula. If the calculated answer comes out with a negative number for the combined focal length, it indicates that the combined system of two lenses has a virtual rather than a real focus. Measure the combined focal length of any two lenses using the procedures described above. Place the two lenses in a beam of collimated light, measure the distance between the two lenses, and predict the combined focal length of the system. Turn on the laser and try this, checking the accuracy of your predictions.

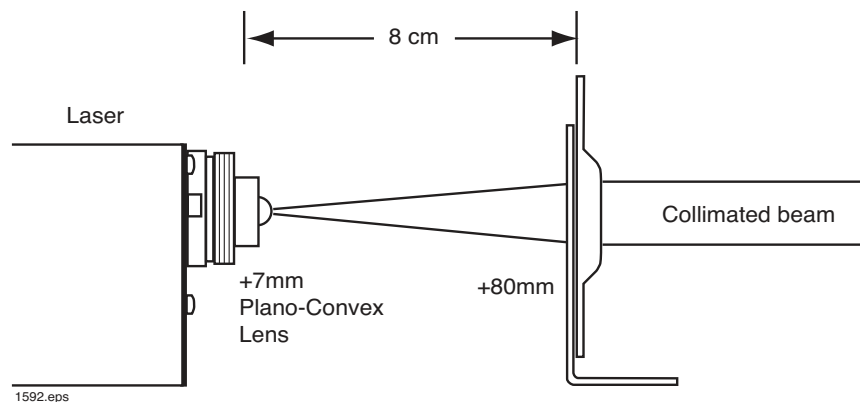

Galilean telescope arrangement of lenses produces enlarged collimated beam.

EXPERIMENT 7. FOCALTY KNIFE-EDGE TEST

Overview

The Foucault knife-edge test is a standard technique used by astronomers to determine the quality of lenses and curved mirrors. Although this test was traditionally performed with ordinary white light, the monochromatic laser offers much greater precision. The difficulty associated with chromatic aberration of white light tends to mask lens defects caused by faulty grinding or by the use of poor quality glass.

Procedure

- A. Mount a plano-convex lens and +80 converging lens combination in front of the laser to obtain a beam of collimated light using the procedure described in Experiment 6.
- B. Mount the +15 mm (part # 45-652) converging lens in the collimated laser beam. Observe that this lens converges the light to a fine point, after which the light diverges.
- C. Insert a new single-edge razor blade (part # 45-662) into the laser beam at the crossover point as shown on the diagram. If a lens is perfect, the spot on the screen should darken uniformly as the razor blade cuts the beam. If there are any irregularities in the lens, the beam, instead of darkening uniformly, will produce irregularly shaped areas on the screen, some parts of which are brighter than others.
- D. Try examining camera lenses of different quality using the Foucault knife-edge test, and then record your results.

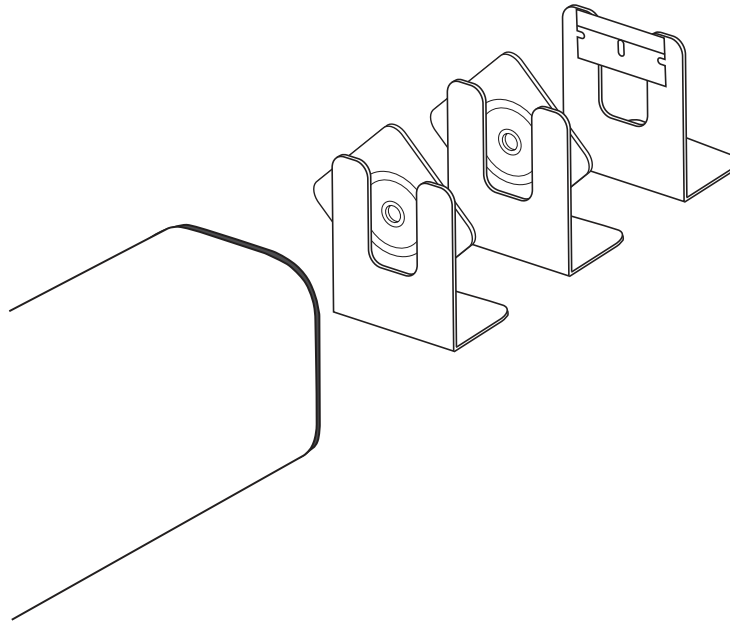
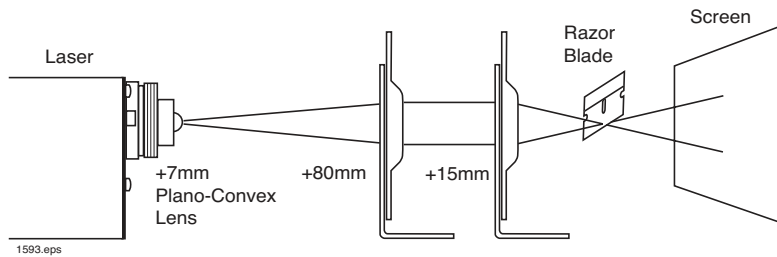

Apparatus arrangement for testing quality of +15mm lens

EXPERIMENT 8. KNIFE-EDGE AND SINGLE SLIT DIFFRACTION

Overview

Although it was formerly believed that light traveled in perfectly straight lines, the laser offers convincing proof that light actually bends, or is diffracted, around small objects. The intense monochromatic laser beam easily demonstrates this phenomenon.

Procedure

A. Knife-edge diffraction can be demonstrated by pointing the laser at a screen, such as a sheet of glossy white paper, approximately three meters away. Slide the edge of a new razor part way into the laser beam and observe the interference pattern on the screen. Close observation will show that there is no sharp shadow of the edge of the razor blade on the screen but instead there is a diffraction pattern consisting of a series of bright and dark fringes

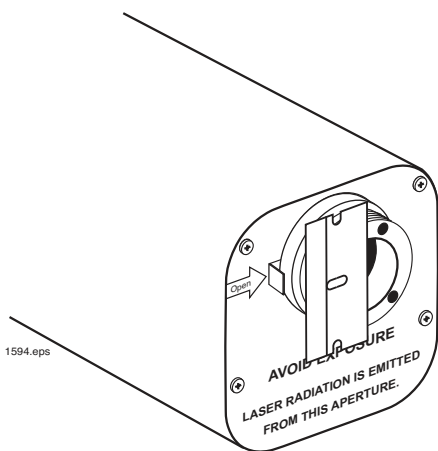

parallel to the edge of the razor blade.

B. Using the same set-up as for the knife-edge diffraction, insert a second razor blade into the other side of the laser beam so the edge diffraction patterns produced by the two razor blades can be seen on the screen simultaneously. Observe the effects on the two diffraction patterns as the two razor blades are brought closer

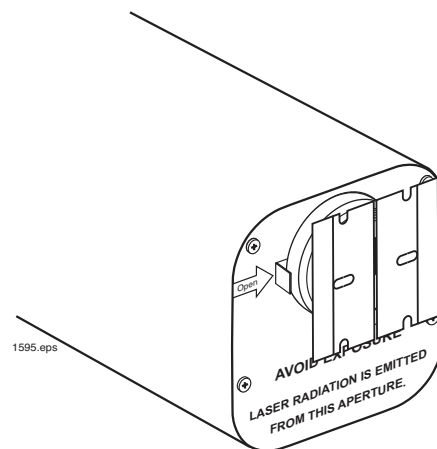

and closer together to form a narrow slit, and their respective diffraction patterns merge.

C. Observe the diffraction patterns formed by sending the laser beam through single slits of known width. The diffraction pattern will consist of a wide central bright fringe with a series of less intense narrower fringes on either side.

The spacing and wavelength of the laser are related by the formula:

$$\sin \theta = \frac{\lambda}{2w}$$

Where: θ is the angle between the peak of the central maximum and the peak of the first bright fringe on either side.

w is the width of the single slit

D. In a darkened room, project the single-slit diffraction pattern on a screen several meters away from the laser. Confirm the relationship defined by the formula in paragraph C.

EXPERIMENT 9. DOUBLE SLIT DIFFRACTION

Overview

When a laser beam passes through two equal, narrow, parallel slits, each slit produces an identical diffraction pattern. If the slits are close enough together, the diffraction patterns overlap and interference occurs. In this experiment, we will observe double-slit diffraction and examine the characteristic diffraction and interference patterns produced as the slit widths and spacing are varied.

Procedure

- A. Place the diffraction slide mosaic (# IF-508 furnished with the Optics Education Kit) in front of the laser so the beam is transmitted through the first of the four double slits (labeled $25_u \times 25_u$). The distance between slits is approximately 4.5×10^{-5} m. Observe the diffraction pattern that appears on a screen one meter from the laser. At first glance, the pattern seems similar to the diffraction pattern produced by a single slit, but on closer observation, you can see several interference fringes within the diffraction pattern produced by a single slit. Use a photometer or power meter to measure the light intensity of the interference maxima (bright fringes) in various parts of the diffraction
- B. Using the same set-up as in Step A, observe the double-slit diffraction pattern that is produced by the second pair of slits (marked $25_u \times 35_u$). These slits are the same width, but their separation, d , is approximately 5.8×10^{-5} m. Compare this diffraction pattern with that obtained in Step A, referring to the original pattern if necessary.

- C. Observe the diffraction pattern produced by the third pair of slits (marked $25_u \times 50_u$). The separation, d , is approximately 7.5×10^{-5} m. Compare this pattern with those from steps A and B.
- D. Considering the findings and observations you made in steps A-C, predict the diffraction pattern of the fourth pair of slits (marked $50_u \times 50_u$). The slit width, w , is twice that of the others, and separation, d , is approximately 10×10^{-5} m. Use the laser to check the accuracy of your prediction.
- E. The well-known formula that relates the wave-length of light and the spacing of interference fringe is:

$$\lambda = d \cdot \sin \theta$$

Where: λ is the wavelength of light (632.8×10^{-9} m for a helium-neon laser)

d is the distance in meters between slits

$\sin \theta$ is the distance between two adjacent interference fringes on the screen divided by the distance between the diffraction slide and the screen.

- F. Using long distances between the laser and the screen to minimize error, calculate the exact distance, d , between each pair of slits on your slide.
- G. Use a different distance between the laser and the screen and repeat Step F. The results obtained for slit separation in each case should be identical.

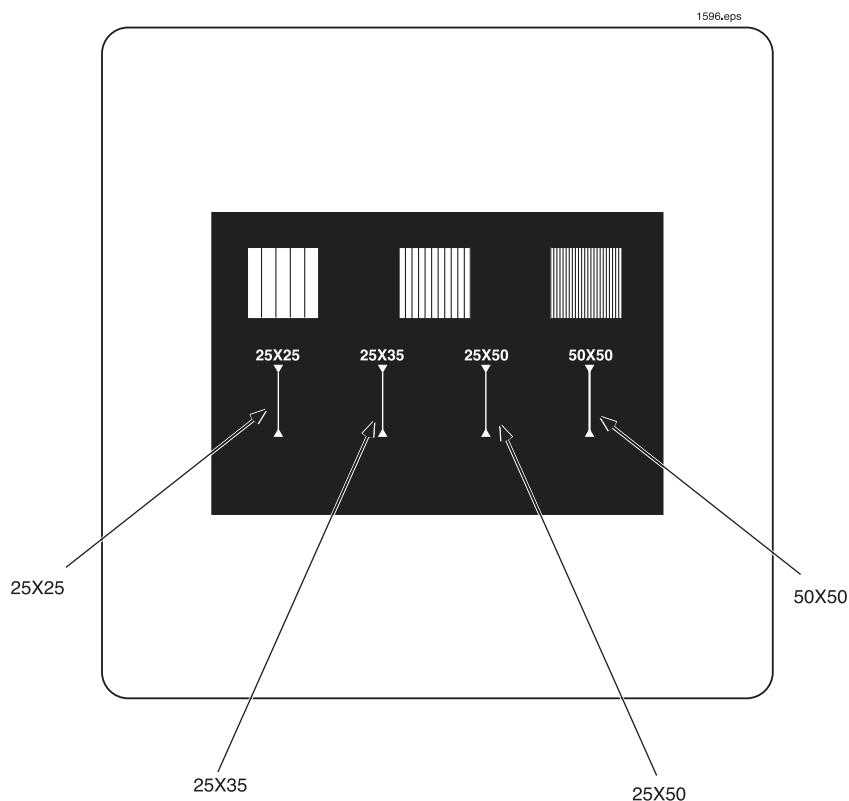

EXPERIMENT 10. MULTIPLE-SLIT DIFFRACTION USING GRATINGS

Overview

When laser light is transmitted through a series of narrow parallel slits spaced closely together, each slit produces a diffraction pattern that overlaps the patterns produced by the others. If the slits are evenly spaced, a pattern very similar to that of the double slits emerges, but much brighter. In this experiment we will investigate the diffraction and interference patterns produced by three diffraction gratings. Because photographic film shrinks during processing, all of the line spaces depicted in the illustrations and instructions below should be taken as approximate values.

Procedure

- Aim the laser at a screen at least three meters away. Hold the diffraction slide mosaic in the laser beam so the diffraction grating with 25 lines/mm is in the beam. Walk close to the screen and carefully observe the diffraction pattern. Compare the fine detail of the bright fringes with the detail of the double-slit diffraction patterns in the previous experiment.
- Place the middle diffraction pattern, with 50 lines/mm, in the laser beam and again observe the pattern carefully. Compare the spacing of fringes in this diffraction pattern with the spacing from the 25 line/mm grating observed in Step A. Record your results.

- The formula that relates wavelength of the light and spacing of slits is identical to the one used for double slit diffraction:

$$\lambda = d \sin \theta$$

Where λ is the wavelength of light (6.328×10^{-7} meter)
 d is the distance between adjacent slits
 $\sin \theta$ is the distance between two adjacent fringes divided by the distance between that diffraction grating and the screen

Adjust the positions of the laser and the screen so they are five meters apart. Using the formula above, determine the distance (d) between adjacent slits on each of the three diffraction gratings.

- Change the distance between the laser and the screen to a different value and repeat Step C. If your measurements and calculations were correct, the results should be identical to those previously determined. This will provide confidence in your measurement techniques and calculations.

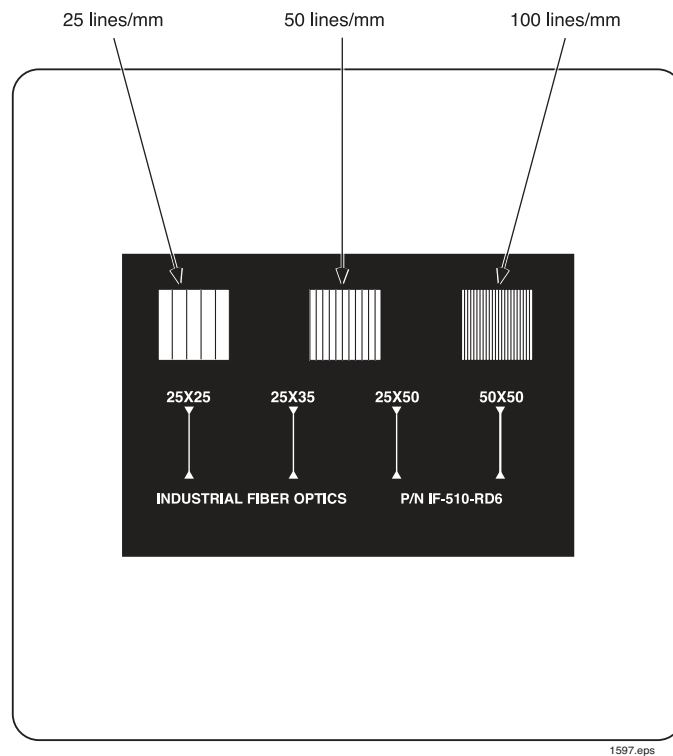

EXPERIMENT 11. INTERFERENCE BY MULTIPLE INTERNAL REFLECTIONS IN GLASS

Overview

When a laser beam passes through a flat glass plate, some of the light is transmitted and some is internally reflected in the glass. As reflected light is subsequently emitted from both sides of a microscope slide at intervals along the surfaces, interference occurs among the multiple beams of coherent light. In this experiment, we shall investigate the nature of this interference.

Procedure

A. Place the plano-convex lens (+7 mm) and the converging lens +80 mm (part # 45-654) in the laser beam. Adjust the distance between them to make a spot about 15 cm in diameter on a glossy white screen approximately one meter from the laser. Place a microscope slide so its surface makes an angle of 90° with the beam. Slight adjustments of the slide position should produce an interference pattern on the screen, which consists of concentric light and dark circles. The dark circles are caused by

destructive interference between the waves transmitted directly through the glass and those reflected internally. The waves reflected internally have a different path length and are one or more half wavelengths out of phase with the directly transmitted waves.

- B. Spectacular interference patterns may be obtained by placing the microscope slide in the laser beam as shown in the diagram so that it is almost parallel to the beam. This will produce two sets of interference patterns: one coming from each surface of the glass plate. Observe the two patterns carefully and account for the similarities and differences between them.
- C. Slowly rotate the plate, observing the shifts that take place in the position of one of the patterns and in the fringes of both patterns. Record your observations, then account for them based on your knowledge of the theory of reflection and the phase changes that take place as light waves pass through the interfaces between air and glass.

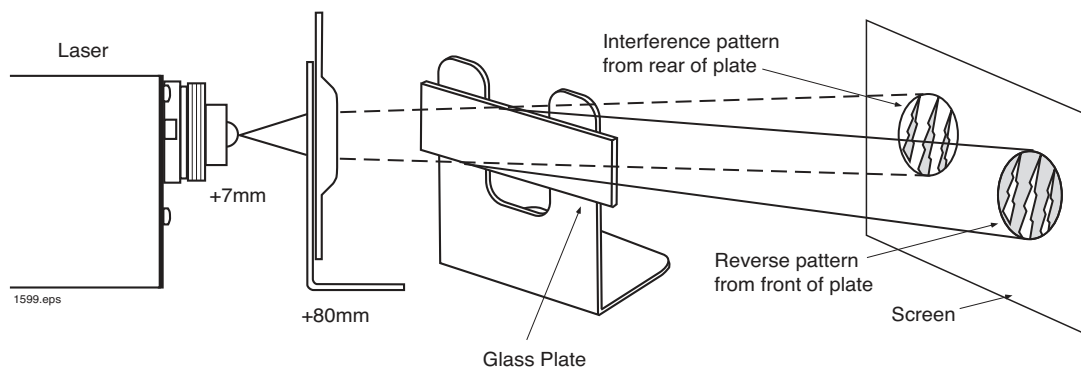

Interference patterns produced by internal reflections emerge from rear of glass plate, and reversed patterns emerge from the front.

EXPERIMENT 12. LLOYD'S MIRROR

Overview

Lloyd's Mirror is a classic experiment in optics first described in 1834. It is a simple technique for finding the wavelength of light using a method that is very similar to that of Young's Slit. This experiment is usually conducted in advanced optics courses because of difficulties in alignment when using ordinary monochromatic light. However, with a laser beam alignment is simple, and excellent quantitative results may be obtained in a few minutes.

Procedure

- A. Mount the plano-convex lens (+7 mm) in front of the laser. Mount the converging lens (+80 mm) about 10 cm in front of the planoconvex lens. Adjust the position of the converging lens so the laser produces the smallest possible spot on a glossy white paper screen placed about three meters in front of the laser.
- B. Mount a small L-Shaped carrier on a Maggie mount so it forms a horizontal ledge near the center of the panel. Place a microscope slide on this ledge and mount the whole assembly between the two lenses as shown on the diagram. Adjust the height of the horizontal glass plate so the laser beam just grazes its upper surface. Adjust the position of the glass plate so a second spot appears on the screen about an inch above the first. Because the laser beam is essentially parallel, the location of the source that produces the lower spot on the screen is at the principle focus of the plano-convex lens. This is located +7 mm behind the plano-convex lens, as shown on the next diagram. The second spot produced by the mirror comes from a virtual source a short distance below the actual source.

- C. Calculate the distance between the actual source and the virtual source using the relationship:

$$\frac{d}{D} = \frac{p}{q}$$

- Where:
- d is the distance between the actual and virtual sources
 - D is the distance between the two spots on the screen
 - p is the object distance
 - q is the image distance

- C. Carefully remove the converging lens from the apparatus set-up without disturbing any of the other components. Without this lens, the cones of light coming from the two sources will partially overlap, forming an interference pattern on the screen. This pattern will consist of alternate red and black horizontal lines (fringes) along the bottom of the illuminated area on the screen. The alternate fringes provide evidence of constructive and destructive interference as the light from the two sources arrives on the screen in or out of phase.

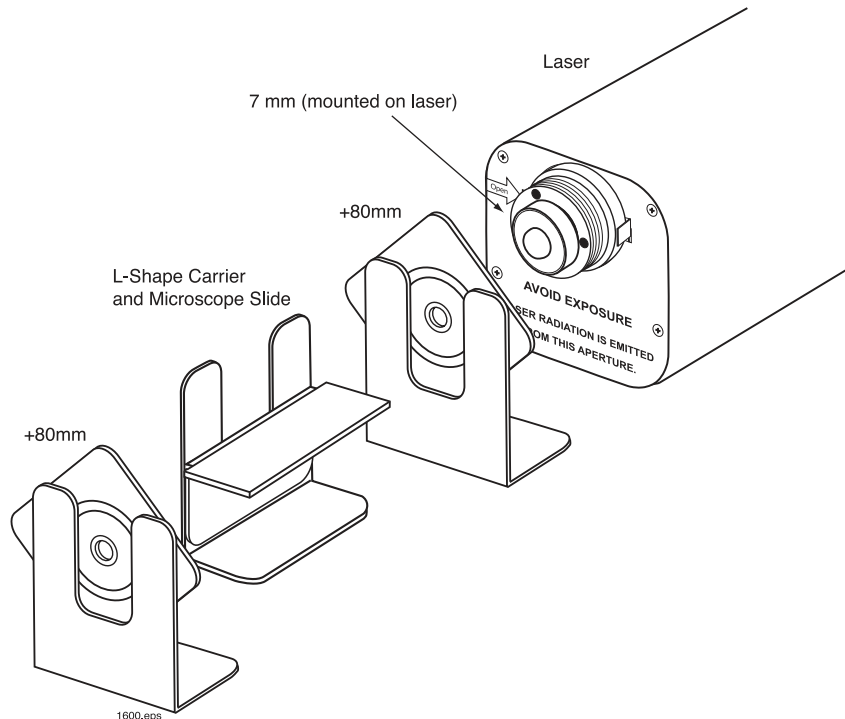

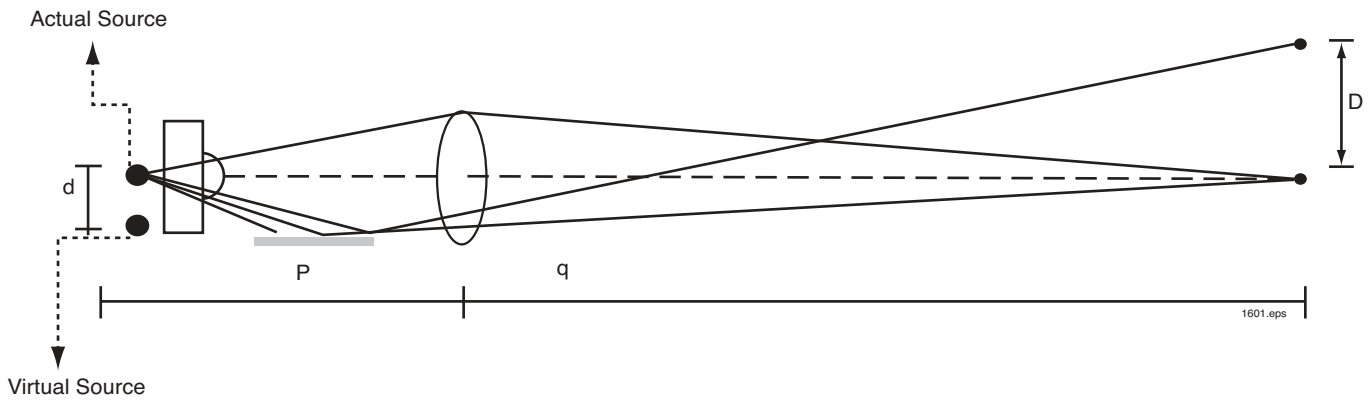

Calculating the distance between two sources by measuring distances P, q and d.

D. Calculate the wavelength of the laser light using the formulas for double-slit diffraction given in a previous experiment. The relationship is:

$$\lambda = d \cdot \sin \theta$$

Where: λ is the wavelength of the laser light to be found

d is the distance between the two sources (determined in the step above)

$\sin \theta$ is the distance between any two bright fringes or any two dark fringes on the screen divided by the distance between the screen and the source

NOTE: The distance between fringes on a screen is easily measured by projecting the interference fringes on a white ruler that has a millimeter scale.

To find the distance between two bright fringes, count the total number of bright fringes in a distance of 24 cm. If you find it difficult to count the fringes, use a magnifying glass held near the screen. If the first few fringes near the bottom of the illuminated area are irregularly spaced, use the other fringes a bit higher up on the screen.

EXPERIMENT 13. MICHELSON INTERFEROMETER (ELEMENTARY FORM)

Overview

The Michelson interferometer is a precise measuring device with many applications in science and industry. It consists of a partial mirror called a beam splitter and two front surface mirrors. Before the advent of lasers, aligning these components was very difficult to achieve under ordinary laboratory conditions — necessitating the use of expensive and intricate alignment apparatus. By using a laser beam however, alignment requires only minutes.

Procedure

- A. Mount a front surface mirror on the Maggie Mount platform as shown in the diagram. To permit both horizontal and vertical adjustments to the mirror, use the combination vertical and L carriers as illustrated.
- B. Adjust the height of the mirror so the laser beam strikes its center. Aim the mirror so the reflected laser beam returns to the front of the laser and strikes it just above the aperture.
- C. Mount the beam splitter on a vertical Maggie carrier and place it in the laser beam at an angle of 45 degrees, as shown in the diagram.
- B. Place a sheet of glossy white paper in front of the beam splitter at right angles to the laser beam. A bright red spot should appear on the screen due to partial reflection of the returning laser beam from the beam splitter.
- E. Mount the second front surface mirror in the position shown in the diagram. Adjust the mirror so it reflects the laser beam back through the beam splitter and forms a second spot on the screen.
- F. Make slight adjustments to the two mirrors so the two red spots on the screen come together and are superimposed on each other.
- G. Enlarge the size of the spot on the screen using plano-convex lens # 45-632. When the spot is enlarged, you should be able to see alternate light and dark fringes on the screen caused by interference between the reflected laser beams arriving by separate paths.
- H. Blow some air along the surface of the apparatus and observe the shifting of light and dark fringes on the screen in response to the slightest movement.
- I. To demonstrate how the Michelson interferometer can detect even the slightest movement, try holding one of the mirrors steady in your hand instead of having it mounted on the surface. You will find it nearly impossible to keep the interference fringes stationary on the screen, due to almost imperceptible movements of even the steadiest hand.

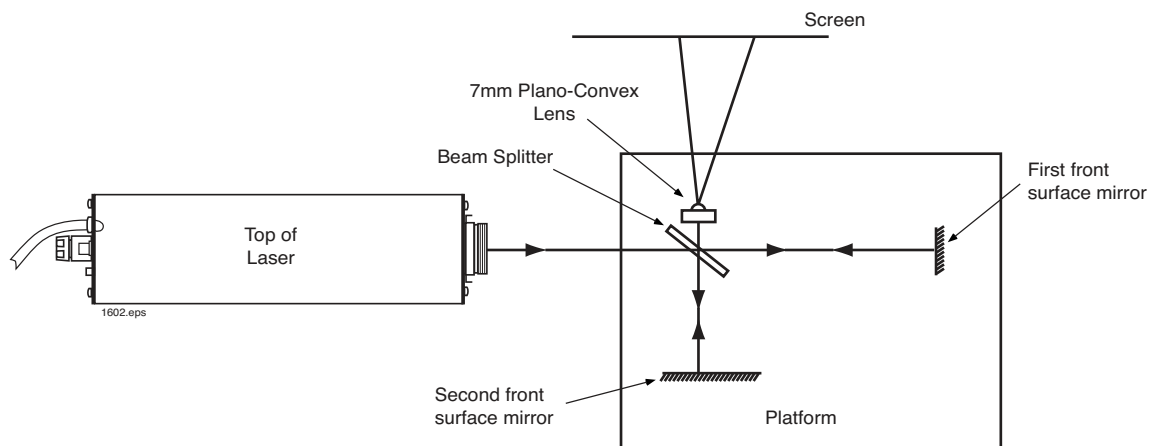

Top view of platform with mirrors and beam splitter. The plano-convex lens enlarges the interference pattern on the screen.

Mirror mounting
technique for
Step A

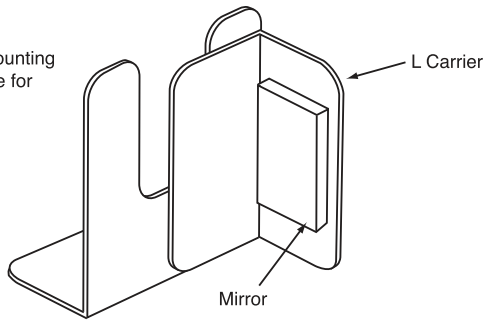

Spot must appear
away from hole

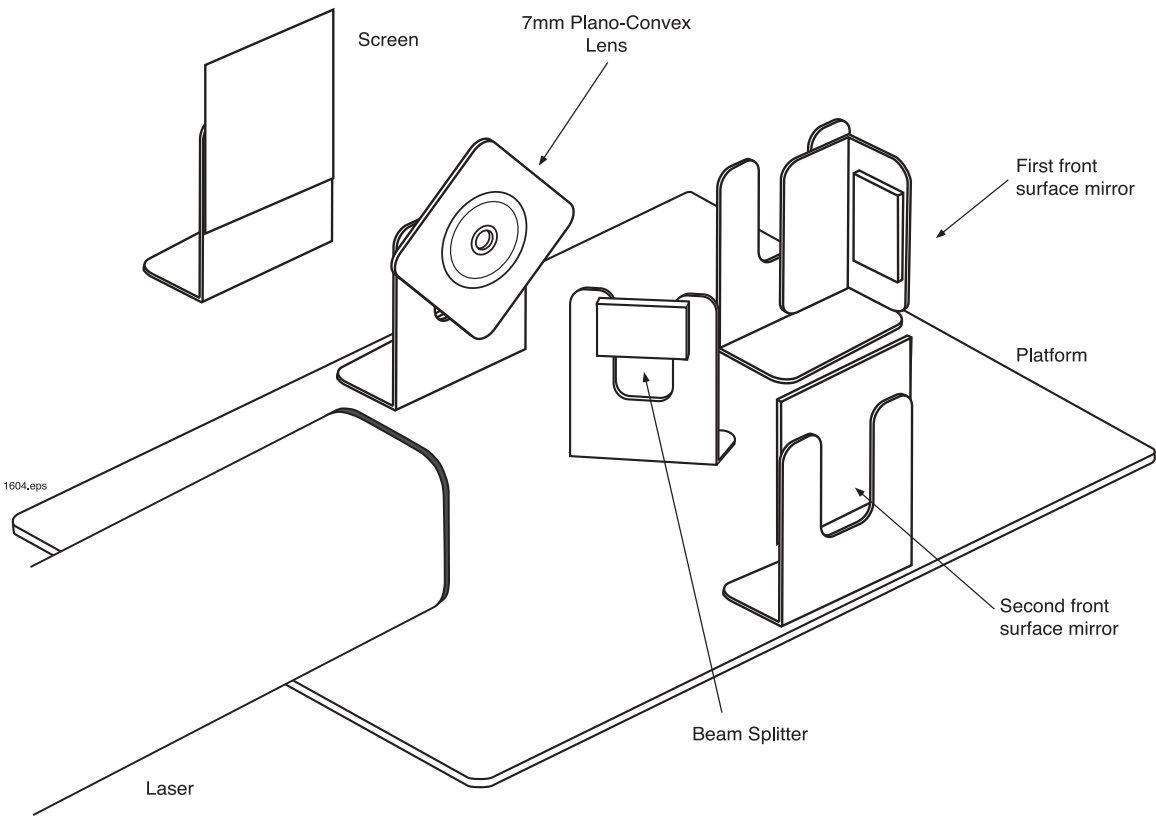

EXPERIMENT 14. THIN FILM IN INTERFERENCE USING AN AIR WEDGE

Overview

When a thin layer of air separates two sheets of flat glass, multiple reflections of light occur at the air and glass interfaces. If the thickness of the air layer is adjusted so it is $\frac{1}{2}$ the wavelength of the incoming light (or odd multiples of $\frac{1}{2}$ wavelength), none of the light will be transmitted, although both air and glass are perfectly transparent. In this experiment, the phenomenon of thin film interference will be investigated.

Procedure

- Enlarge the laser beam by mounting plano-convex lens # 45-632 (+7 mm) on the Maggie Mount platform.
- Place a screen one or two meters away at a right angle from the path of the expanded laser beam.
- Hold the air wedge in front of the laser at a position lined up with the screen as shown in the Figure. Rotate the air wedge to

a 45 degree angle so that the reflected part of the laser beam is projected on the screen. You should see dark interference fringes in the reflected beam.

- Vary the thickness of the air layer wedge by squeezing the glass plates together with your fingers in different places around the edge. Observe the changes in the pattern on the screen as you squeeze the glass. Record your observations and explain in a short paragraph why they occurred.

NOTE: Good views of fine interference patterns are sometimes obscured by unavoidable clutter and random interference patterns that develop in the laser optics. To “clean” the laser output, use the +15 mm converging lens (part # 45-652) and a pinhole as a spatial filter. The technique for arranging and adjusting such a spatial filter is described in experiment 17 of this manual.

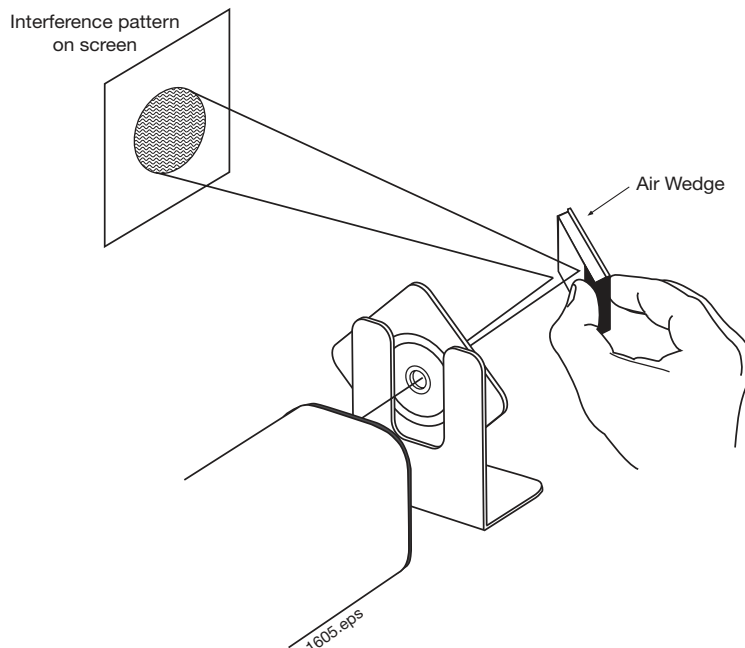
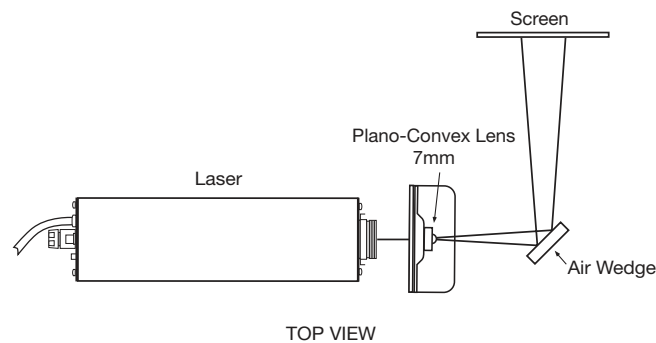

EXPERIMENT 15. DIFFRACTION FROM SMALL HOLES

Overview

In principle, diffraction of a laser beam by a small hole is similar to diffraction by a single slit. A hole is a rotated case of the slit. The opposite edges cause the same diffraction fringes as a slit. But the pattern is circular since the edges are at a constant spacing around the circumference of the hole. Using the bright monochromatic light from a laser, these complex well-defined patterns are easily reproduced for study and investigation.

Procedure

A. Part # 45-663 contains a needle and 10 sheets of aluminum foil. Create a pinhole as follows: Layer 8 to 10 sheets of the foil on a piece of glass. Puncture the stack of aluminum with the needle and select a pinhole from one of the middle layers. If the hole has been made properly, a bull's-eye pattern will form on the screen when the laser beam passes through the hole. A perfectly round pattern on the screen indicates the pinhole is also perfectly round. Experiment at making your pinholes smaller and smaller. The smaller the pinhole, the larger the bull's-eye.

B. Calculate the size of your pinhole by measuring the radius of the Airy disc (the central bright disc in the bull's-eye pattern) on the screen. Do this by using the relationship:

$$d = \frac{L\lambda}{2x}$$

Where: d is the diameter of the pinhole

x is the radius of the Airy disc

L is the distance from the pinhole to the screen

λ is the wavelength of the light (6.328×10^{-7} meter)

C. The spark produced by a Tesla coil can be used to make a small pinhole. Adjust the coil to work at its slowest rate and make a series of small holes by passing a piece of fresh carbon paper across the spark gap between the Tesla coil and a grounded metal plate. Using the procedure of Step B, measure the sizes of the pinholes and cut out and mount the better ones for future use.

Refer to a textbook on optics to learn more about the theory of the Airy disc and its practical use in astronomical observations.

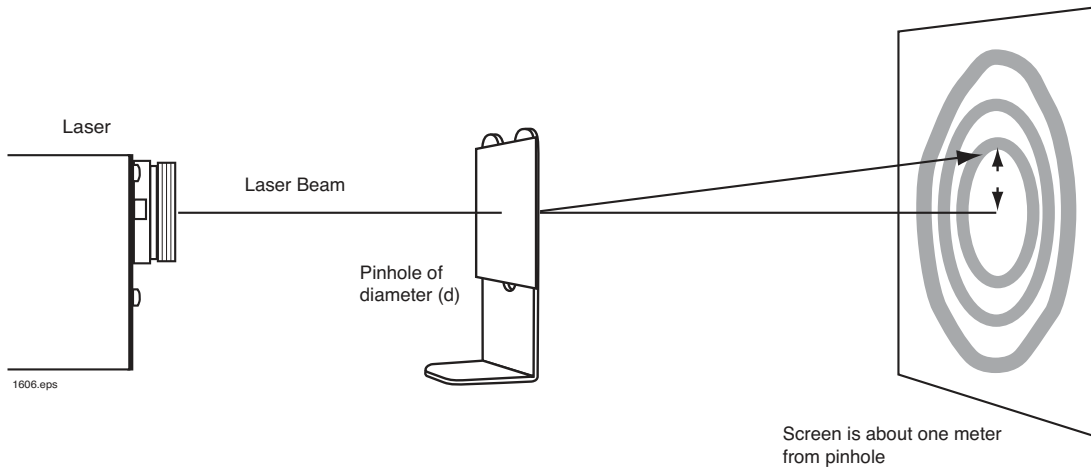

EXPERIMENT 16. OBSERVING HOLOGRAMS

Overview

One of the most striking applications of continuous laser light is its ability to make three-dimensional photographs called holograms.

We create a hologram by exposing a photographic emulsion to a scene that is wholly illuminated with laser light. The negative is simultaneously exposed to the reference beam that comes directly from the laser. As light from the two sources falls on the negative, an interference pattern is recorded. In places where the light from the two sources is in phase, constructive interference occurs, forming a bright spot. Where the light is out of phase, destructive interference occurs, forming a dark spot. These bright and dark areas are so close to each other on the negative that they can be seen only with the aid of a high-power microscope.

We hope the exploratory exercises described below will motivate students to make their own holographs using laser beams and special high-resolution film. You could help to pioneer the development of holography for the future.

Procedure

A. Spread the laser beam by placing the plano-convex lens (+7 mm) over the laser aperture.

B. Place the hologram in the laser beam about one meter from the laser. At this distance, the diameter of the beam should be approximately 7 cm so that it illuminates most of the hologram.

NOTE: Although students are always cautioned not to look directly into the laser aperture because of possible danger to the eye, it is perfectly safe to do this when a Class II laser beam has been spread to a diameter of seven centimeters. Spreading the beam out to a spot this size reduces the energy concentration to less than one-thousandth the value of the original laser beam.

C. With the room darkened, look in the area about 20 centimeters below the laser aperture. You should be able to see a three dimensional scene that was recorded on the hologram.

D. While holding the hologram stationary in the laser beam, move your head slowly up and down and from right to left. As your eyes view the objects from different angles, you should be able to see the objects from different perspectives just as you would if there were an actual group or real objects in front of you.

E. Make a hole about one centimeter in diameter in the center of a sheet of notepaper and move this over the face of the hologram while looking through it at the three-dimensional scene. Each portion of the hologram contains all the information for viewing the entire scene. There are slight differences, however, among the various portions of the hologram. Describe these differences as you view the scene.

F. While looking at the scene through the hologram, reach out and try to touch various portions of the objects that you see. Notice the illusion of depth perception as your hand moves further away from or closer to the various objects.

G. Holding the hologram in the laser beam, lower your head and look at the area about 20 centimeters above the laser aperture. A second image should appear at this location. Describe this image and compare it with the first one.

H. Look at the hologram through a high-power microscope. Notice the variations in tone that form the interference pattern.

NOTE: When looking at the hologram in ordinary light, you will notice that there are irregularly shaped light and dark patterns on the film. These variations are not the actual holograph pattern that makes the scene you saw. They actually are the equivalent of fingerprint smudges on a photographic print. On the hologram, these visible tone variations consist of unwanted interference patterns caused by dust in the air and on the laser itself. These should not be confused with the actual hologram pattern — it is microscopic in size.

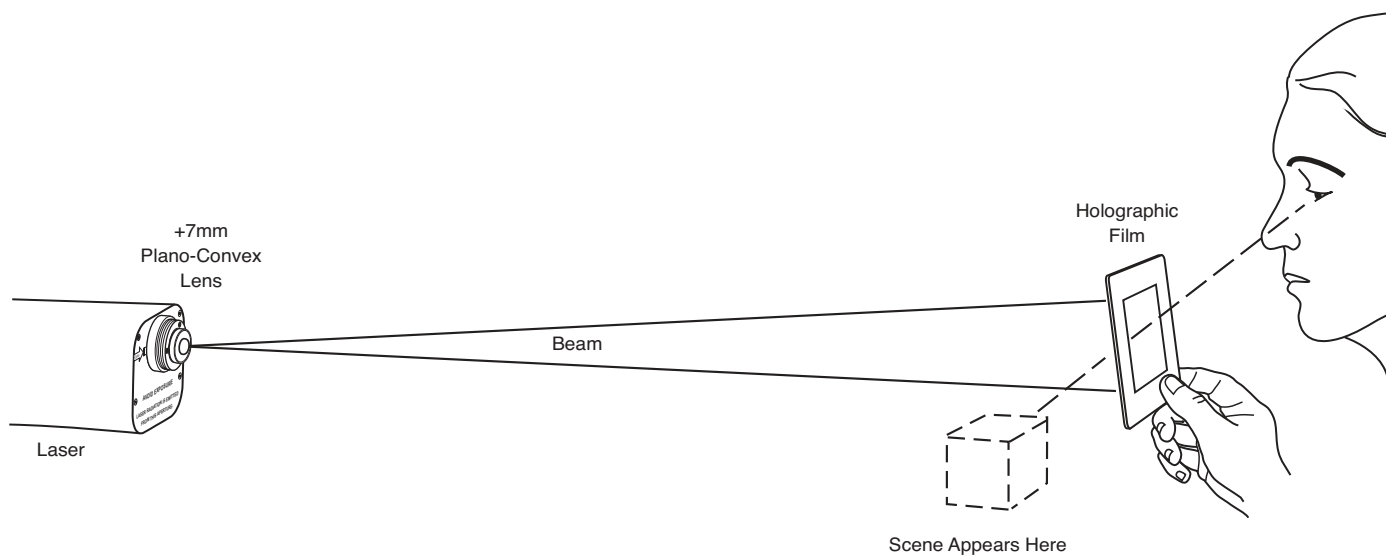

EXPERIMENT 17. SPATIAL FILTERING

Overview

The mottled appearance of an enlarged laser beam is due to unavoidable specks of dust and minor irregularities in the laser optics. This causes complex diffraction patterns that appear in the laser output as unwanted “noise”. The construction of the spatial filter described in the experiment helps remove clutter in the laser beam. It will also be useful for other experiments that require observing fine details in diffraction patterns.

The spatial filter works on the principle that a lens will focus the “clean” aspects of a laser beam to a sharp point that will barely pass through a small pinhole. The noise and interference patterns are not focused in the same location and are thus screened out by the pinhole.

Procedure

A. Mount a +15 mm (part # 45-652) focal length lens and pinhole on the Maggie Mount platform as shown in the diagram. No pinholes are furnished with the Optics Education Kit. But one can be ordered through an optics supplier or made as follows: Part # 45-663 contains a needle and 10 sheets of aluminum foil. Create a pinhole by placing 8 to 10 sheets of aluminum foil on a piece of glass. Puncture the stack of aluminum with the needle

and select a pinhole from one of the middle layers. Use tape to attach the foil to the Maggie Mount.

- B. Move the pinhole carrier to a position about 15 mm from the lens, where the focal plane of the lens would be located. Check this position by turning on the laser and using the lens to focus the beam to the smallest possible spot on the pinhole carrier. Aim the beam to a point that is very close to the pinhole, but not on the hole itself.
- C. Check that the pinhole carrier is positioned at the exact focal plane of the lens and perpendicular to the laser beam by trying a simple trick. Slowly move the laser a short distance up and down and from side to side, while aiming it at various portions of the lens. Observe the movements of the small red spot on the diffraction slide mosaic. If the carrier is at the lens focal plane, movement of the small red spot will be at a minimum. The spot may even appear to be stationary.
- D. When you are certain that the carrier is on the focal point of the lens, manipulate the pinhole until the laser beam passes right through it and diverges on the other side. The smaller the hole used, the cleaner the beam, but it will be more difficult to make the proper adjustment.

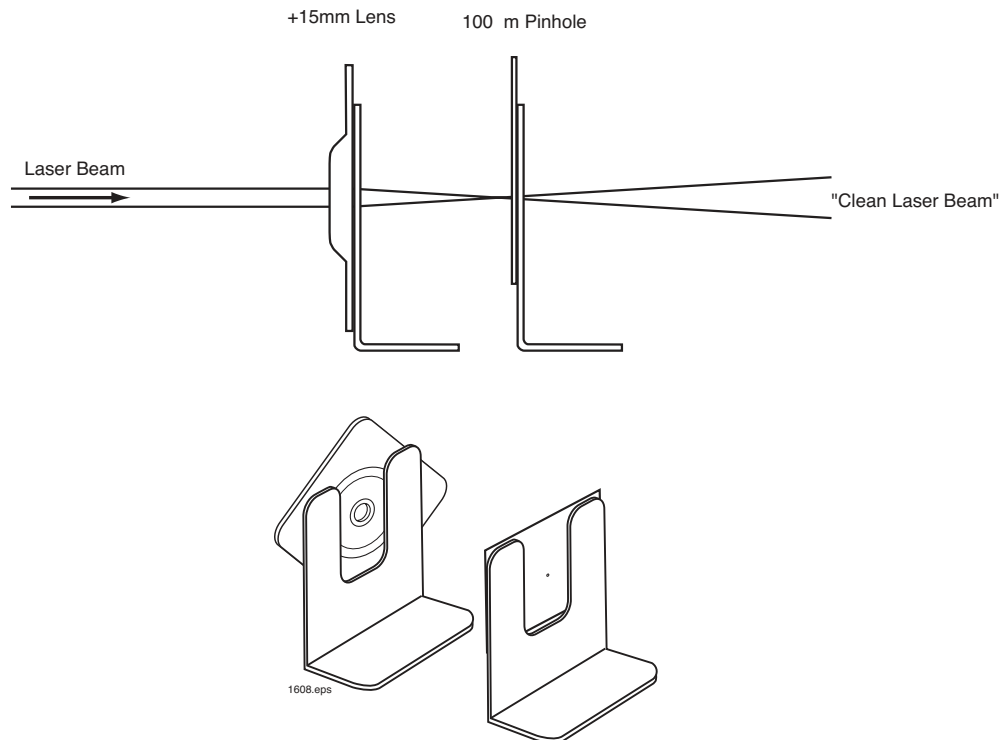

EXPERIMENT 18. DIFFRACTION PATTERNS FROM A RULER

Overview

Diffraction is often demonstrated with narrow single slits, closely spaced double slits, and diffraction gratings. But it also can be observed in common objects. An example is an ordinary plastic ruler with fine black markings spaced at intervals of one millimeter or sixteenths of an inch.

Procedure

A. As shown in the diagram mount the 6-inch ruler furnished with the Optics Education Kit. The laser beam should just graze the ruler so it illuminates approximately three centimeters of the metric scale.

B. Place a screen about two meters away from the laser so the diffraction pattern from the ruler can be observed. The pattern will consist of alternate bright and dark areas spaced at regular intervals. Small adjustments of the ruler with respect to the laser beam may be necessary to sharpen the pattern.

C. Place a plano-convex lens in the laser beam at the end of the ruler so that fine details of the diffraction pattern can be observed on the screen. When this has been done, move the ruler very slightly while watching the screen. Try to explain the causes of the diffraction patterns that you observe.

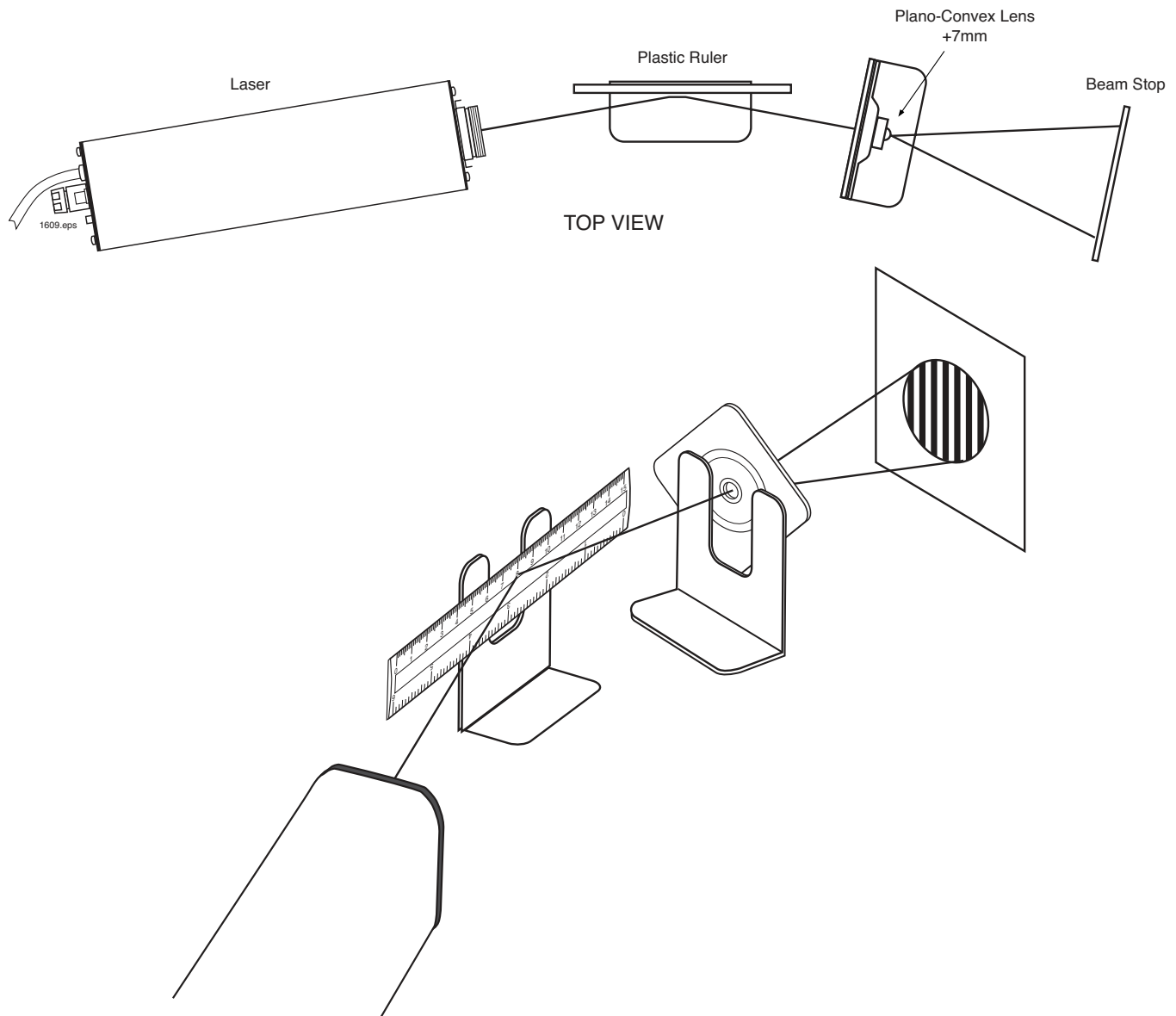

EXPERIMENT 19. MEASURING THE CURVATURE OF THE EARTH

Overview

A laser beam in air is essentially a straight line. By using this line as a reference, the curvature of the earth can be measured with a fair degree of accuracy.

Procedure

1. On a large frozen lake*, set up a laser and a target as far apart as possible. A distance of at least a mile will enhance the measurement precision.
2. Collimate the laser beam (using the procedure described in Experiment 6).
3. Aim the beam at the distant target so the distance of the beam above the ice at the laser is the same as the distance of the beam above the ice at the target.
4. At a point midway between the laser beam and the target, measure the height of the beam above the ice. Because of the curvature of the earth, the beam will be closer to the ice at this location.
5. Calculate the radius of the earth using the relationship:

$$R=L/8H$$

Where: R is the radius of the earth

L is the distance between the laser and the target

H is the difference of beam heights at the middle and ends of the run

Compare the heights of the laser beam above the water surface at three locations specified above. When the target is three miles from the laser, the height difference of the laser beam at the ends and middle of the run should be about 1.5 feet.

*If a large frozen lake is unavailable for this experiment, try it over a large quiet body of water on a day when there are few or no waves.

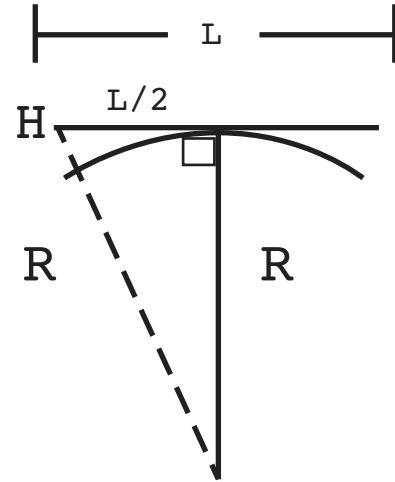

Formula Derivation

$$R^2 + (L/2)^2 = (R + H)^2$$

$$R^2 + \frac{L^2}{4} = R^2 + 2RH + H^2$$

$$\frac{L^2}{4} = 2RH + H^2$$

Since H^2 is small, it can be ignored, thus,

$$R = \frac{L^2}{8H}$$

**EXPERIMENTS THAT CAN BE
PERFORMED IN THEIR ENTIRETY
WITH THE ADDITION OF AN
IFO 45-610 OPTIONAL ACCESSORIES KIT**

EXPERIMENT 20. BEAM INTENSITY

Overview

One of the chief advantages of a laser is that its primary beam is very intense. Because the beam does not diverge much the intensity does not fall off rapidly with distance. In this experiment we will measure these characteristics of your laser.

>>>CAUTION: Be careful not to look directly into the laser beam yourself and take precautions that the beam does not shine directly into the eyes of others in the immediate vicinity.

Procedure

- Hold a sheet of glossy white paper in front of the laser and note the intensity of the red spot. Back away from the laser for a distance of 100 meters or more while noting the beam intensity on the paper at one-meter intervals.
- Use a photometer such as the one furnished with the Advanced Laser Optics Education Kit to measure the intensity of the beam at various distances from the aperture. The beam may spread somewhat at large distances. Make sure the photometer aperture is large enough to admit the entire laser beam. For future reference, make a graph of the beam intensity versus distance. On the graph note the relevant experimental data such as the type and model of light meter, the range setting and the ambient light conditions.

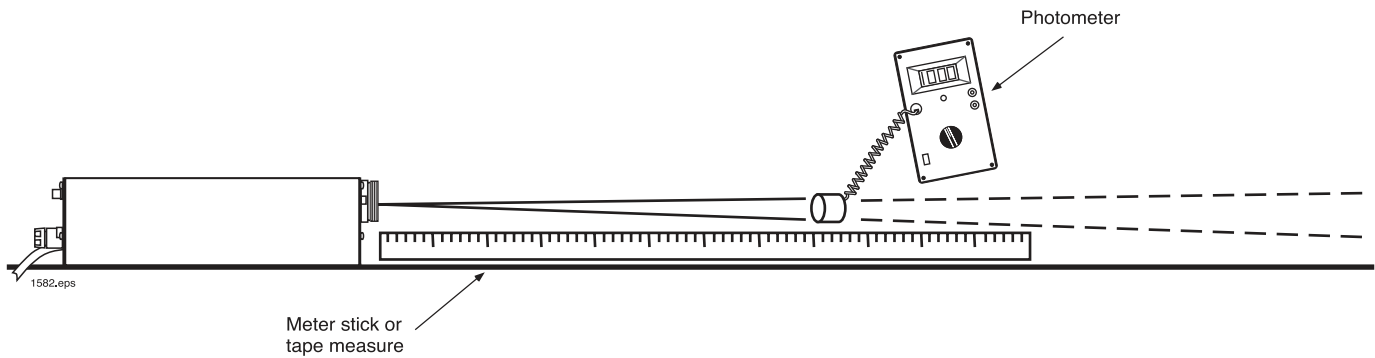

Measure the light intensity at various distances from the laser using a photometer

EXPERIMENT 21. DIVERGENCE OF A LASER BEAM

Overview

One of the chief advantages of a laser is that it produces a beam of light whose edges are parallel. Any deviation from perfect parallelism eventually causes the beam to diverge and spread out its energy, becoming weaker and weaker with distance. But perfect parallelism is difficult or even impossible to achieve under practical conditions. Each laser is guaranteed by the manufacturer to produce a beam that is somewhere between perfect parallelism and a specified amount of divergence. In this experiment we'll measure the actual divergence of our laser beam.

Procedure

A. Measure the diameter of the laser beam by holding a sheet of millimeter scaled graph paper in front of the laser near the exit aperture. Record the diameter of the bright red spot on the graph paper.

NOTE: The laser beam is very intense at short distances from the laser. When the spot is reflected from a white background it may appear larger than the actual beam diameter. Try using a piece of clear tape stretched across a Maggie Mount to get a more

accurate idea of beam diameter. Use a fine point felt tip marker to gradually block out the laser beam, and then transfer the tape to the graph paper to gauge the diameter.

- B. Move 10 meters in front of the laser and measure the diameter of the beam again using the same piece of graph paper. Using a long corridor, repeat this procedure at precise 10-meter intervals for the longest distance that is practical. Longer distances reduce the error associated with less than precise measurements of the initial beam diameter. If a sufficient distance is available you may eventually get a beam spread similar to that shown in the figure. The power densities shown can be measured using a photometer like the IFO IF-PM Digital Photometer.
- C. Make a graph plotting the beam diameter in relation to distance and draw the best straight-line connection to the points.
- D. Calculate the angular divergence of the beam by dividing the change in beam diameter by the distance from the laser. The quotient will be the angle measured in radians. Multiply this value by 1000 to obtain the beam divergence angle in conventional units of milliradians.

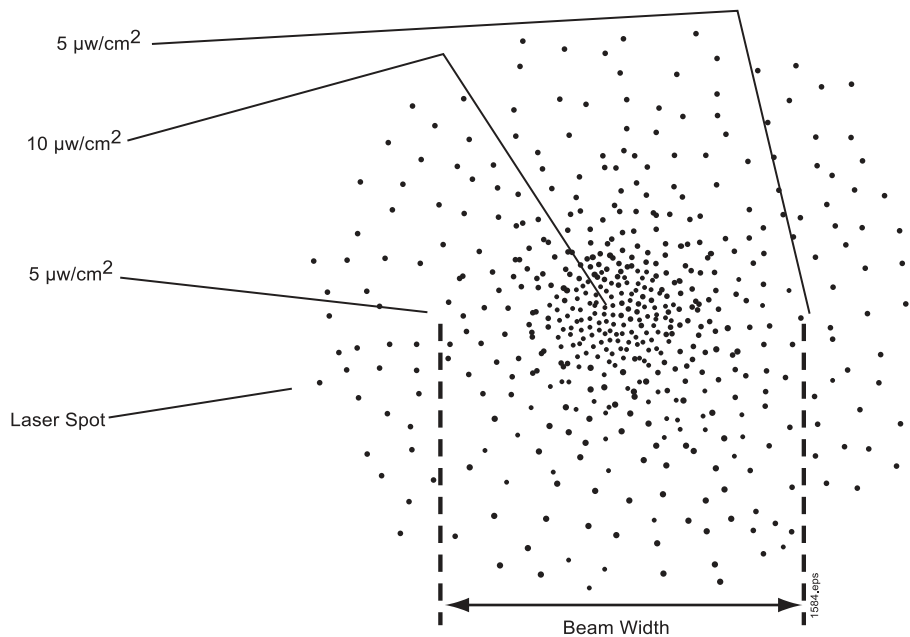

Find the width of the laser beam between half power points as measured with a photometer.

EXPERIMENT 22. LASER SCANNING



Overview

Bar codes are commonplace and the abundance of these symbols can become a stimulus for a lesson on physics at the supermarket.

The Universal Product Code (UPC) symbol on grocery package labels allows automated checkout and enables the store manager to keep a computerized inventory of stock. Bar codes on drug packages permit manufacturers to certify to the Food and Drug Administration that every single package label has been positively checked. No one will get a bottle of penicillin with an aspirin label. Laser scanning also helps automate package sorting and warehouse inventory record keeping.

The lasers most often used in these applications are low-power laser diodes. The beams are eye-safe, but the laser's coherence allows them to be focused to tenths of a millimeter. Tiny lightweight optics scan the beam across the UPC symbols at high speeds so they can be read even if the product is moving quite fast. The laser light is monochromatic, which allows inexpensive colored filters to separate laser signals from background "white-light" noise. (See Experiment 1 - Color).

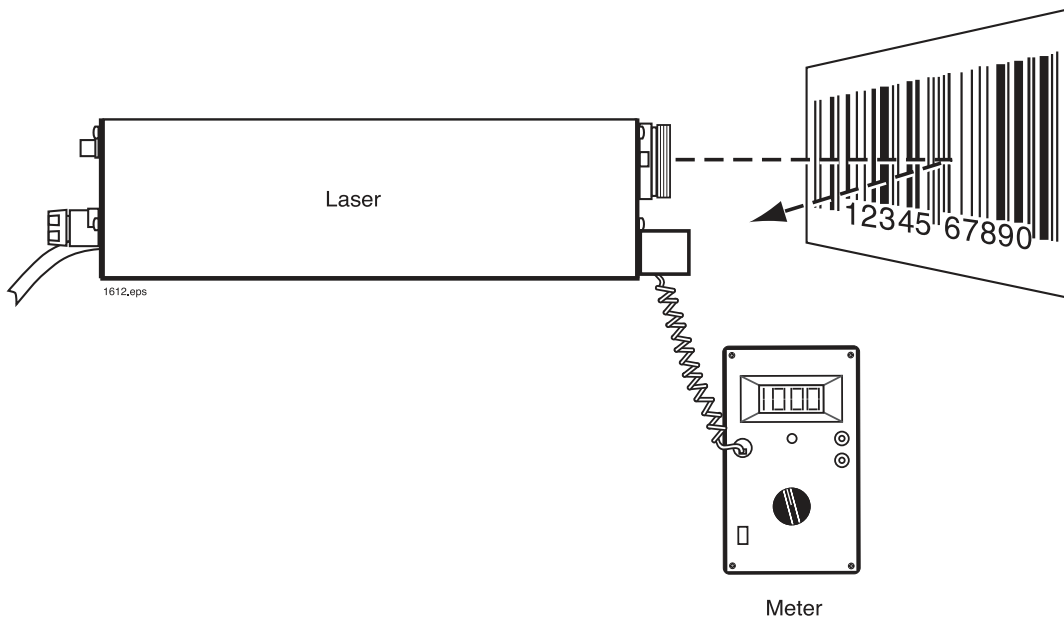

We can use the oversized symbol above for a demonstration of bar code scanning. Use tape or putty to attach the sensor head of IFO's IF-PM photometer to the front-end cap of the laser. Adjust the angle of the sensor so it will detect a beam reflected from a distance of about 10 cm in front of the laser. Connect an analog meter to the V+ and V- jacks on the photometer.

Then from the distance of about 10 cm, sweep the beam across the oversized UPC symbol above. Read the electrical signal deflection on the meter. The signal will rise to a high value when reflected from a white space and fall to a low value when reflected from a black bar.

This exercise can lead to several stimulating problems:

Devise a method to measure bar width. At a given scanning speed, width is a function of the time it takes to traverse a bar.

Build a scanning system. Focus the beam so that it is smaller than the bars being read. Create a scanning pattern by mounting a small mirror on an electric toothbrush or by mounting a mirror on a rotating shaft. Feed the output from the photometer to an oscilloscope so the 1s and 0s can be read. Electronics students can attempt to build a signal processor that changes the analog detector output to a binary signal.

Hints on deciphering bar codes. The sample symbol above begins with a 0 that identifies the code used as the Universal Product Code for grocery use. This code begins with a pair of guard bars, has another two guard bars in the center, and ends with a final pair of guard bars. Numbers are coded in a left-hand format and a right-hand format. Thus, the scanner can read the symbol upside-down and distinguish left from right. Each number is coded as two light and two dark bars. The bars are 1, 2, 3, or 4 units wide, but the set of four bars must always total seven units. The 0 and 5 to the right and left of the main symbol are coded as the first and last numbers in the code.

Thus, the symbol contains 12 digits. The first digit, 0, identifies the types of code. The next 5 left-hand numbers refer to the manufacturer's code number. After the middle guard bars, the 5 right-hand numbers identify the product; for instance, a 6-ounce bar of Brand X perfumed soap. The final number is a check digit. By means of a mathematical algorithm, the computer compares the value of the first eleven digits and compares it with the check

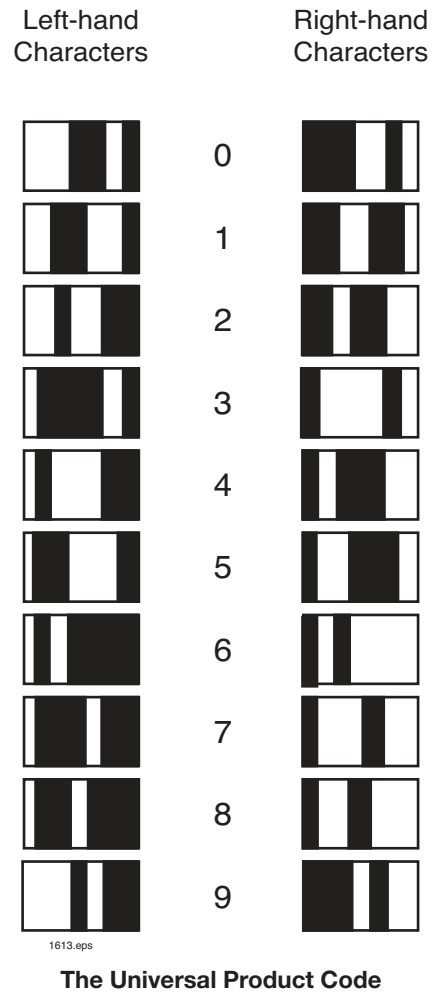

digit. If the symbol has been misread, the check digit calculation will not equal the check digit on the symbol. Since there is no match between the calculated and actual check digit, the computer reports a misread. Note that no pricing information is contained on the symbol. The store manager enters the current prices in a computer. When the symbol is read, a computer search procedure finds the price and item description in the memory and allows a brief reference (SOAP, 6 oz. .26).

EXPERIMENT 23. LIGHT PIPES AND FIBER OPTICS

Overview

Consider an optical material with a relatively high index of refraction relative to its surroundings. As light travels through the material it is internally reflected each time it attempts to leave the boundaries at a large angle of incidence. This results in multiple internal reflections that confine the light so it can follow twists and bends in the medium. The modern application of this principle is in the fiber optic cables used to transmit data in optical form over long distances. This experiment investigates the effect in solids and liquids.

Procedure

A. Drill a 6 mm hole in the side of a tall tin or aluminum can near the bottom. Position a mirror inside the can with putty so the beam from a laser directly overhead is horizontal as it reflects off the mirror and exits the hole. Fill the can with water. As water escapes from the hole, the laser beam will be confined to the water stream trajectory, changing its arc as water pressure decreases in the can. Experiment with different sized holes and with different liquids.

Note: An alternate approach is to use the materials provided in IFO's Tyndall's Historical Experiment (# IF-514) as shown in the

Figure. Aim the laser beam into the rear of the plastic cylinder so that it passes through the opened valve. Place a pail beneath the cylinder and fill it with water being careful not to disturb the initial alignment. Carefully open the valve and observe the behavior of the laser beam as the water drains from the cylinder.

- B. Early glass fibers had very high losses — often greater than 1200 dB/km. The current state of the art has reduced that to fractions of a dB/km. Along the way many techniques and materials were explored to develop low loss light guides. One involved filling quartz tubing with purified trichloroethylene, which reduced losses to less than 20 dB/km. Try making your own light pipes and measure the losses experienced in each case. Low-loss light guides are necessary for long-range laser/fiber optics communications systems.
- C. Use the length of 1 mm plastic optical fiber furnished in the Optics Education Kit, and find the sharpest bend (minimum radius of curvature) that still allows the light guide to confine the light beam. As the radius of a bend decreases, light escapes more readily through the sides of the fiber.

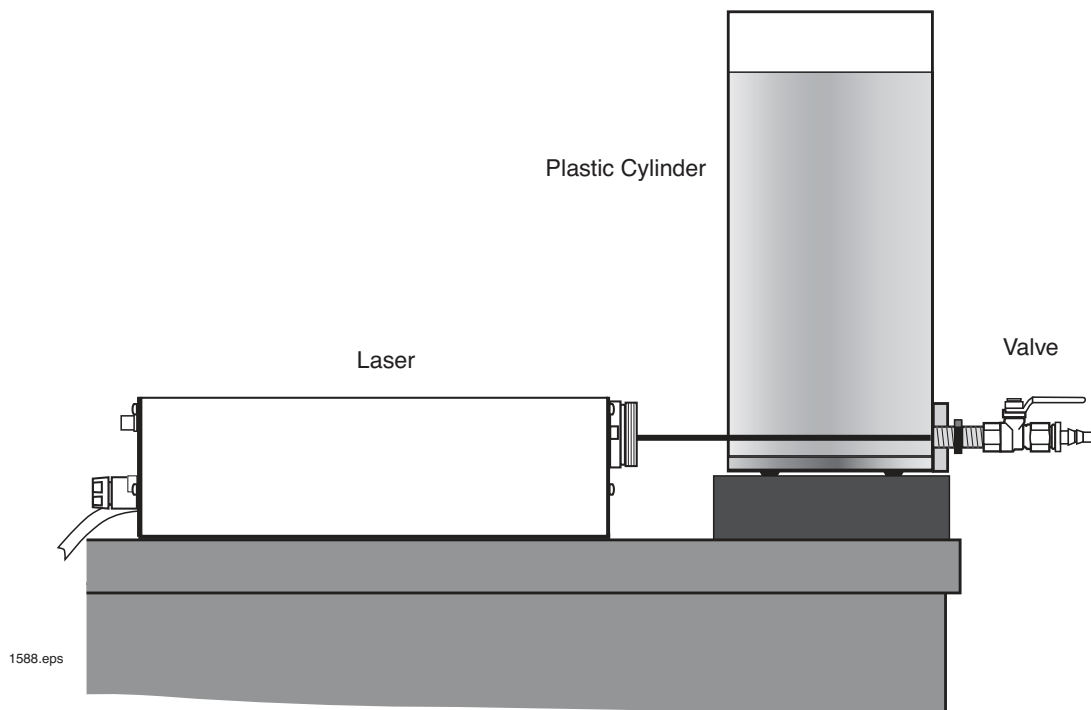

EXPERIMENT 24. THE COLORS IN A RAINBOW

Sir Isaac Newton gave a detailed explanation of the causes of colors in a rainbow in his famous book OPTIKS, published in 1704.

Explanations of scientific phenomena by the original experimenters often are very clearly written in the formal language of their respective eras. But language, like technology, changes form as time progresses. It is the challenge of textbook authors to interpret the original work and present it in a way that preserves the knowledge, yet educates the student in a language they can understand.

For perspective, we quote an excerpt in Newton's own works and copy his original drawings.

From Mr. Newton:

This bow never appears, but where it rains in the sunshine, and may be made artificially by spouting up water that may break aloft, scatter in to drops and fall down like rain. For the sun shining upon these drops certainly causes the bow to appear to a spectator standing in a due position to the rain and sun, hence it is now agreed upon that this bow is made by refraction of the sun's light in drops of falling rain. This was understood by some of the ancients, and of late more fully discovered and explained by famous Antonius de Dominis, Archbishop of Spalato, in his book De Raddis Visus and Lucis, published by his friend Bartolus at Venice, in the year 1611, and written above 20 years before. For he teaches there how the interior bow is made in round drops of rain by two Refractions of the sun's light, and one Reflexion between them, and the exterior by two Refractions, and two sorts of Reflexions between them in each drop of water and proves his explications by experiments made with a Phial full of water and with globes of glass filled with water and placed in the sun to make the Colours of the two Bows appear in them. The same explication DesCartes hath pursued in his Meteors, and mended that of the exterior Bow. But whilst they understood not the true Origin of Colours, it's necessary to pursue it here a little farther.

By the discovered Properties of Light to explain the Colours of the Rain-bow.

For understanding therefore how the Bow is made, let a Drop of Rain, or any other spherical transparent body be represented by the Sphere BNFG (in fig. 14) described with the center C, and semi-diameter CN. And let AN be one of the sun's rays incident upon at N, and thence refracted to F, where let it either go out of the sphere by refraction towards V, or be reflected to G; and at G let it either go out by refraction to R, or be reflected to H; and at H let it go out by refraction towards S, cutting the incident ray in Y. Produce AN and RG, till they meet in X, and upon AX and NF, let fall the perpendiculars CD and CE, and produce CD till it fall upon the Circumference at L. Parallel to the incident ray AN draw the diameter BO, and let as I to R. Now, if you suppose the point of incidence N to move from the point B, continually till it comes to L, the Arch QF will first increase and then decrease, and so will the angle AXR which the rays AN and GR contain;...

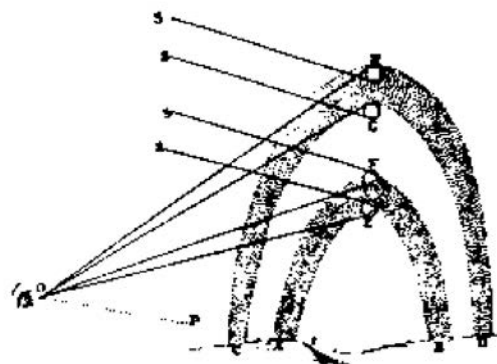
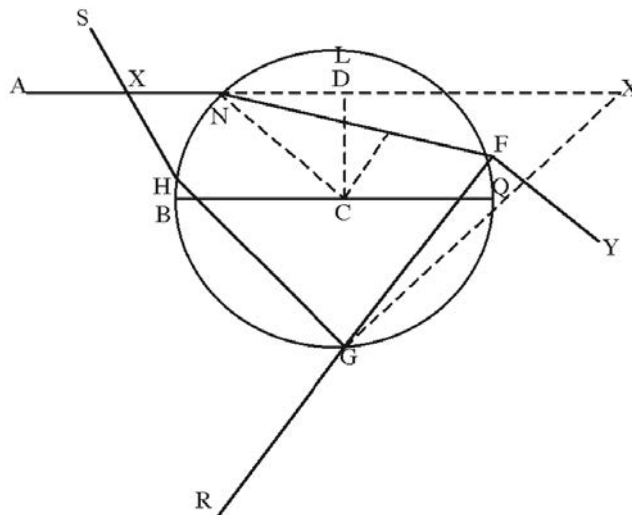

Procedure

Using a low-power He-Ne laser and a glass cylinder filled with water, students can now conduct open-ended experiments that will confirm or refute Newton's explanations, and possibly discover something new.

Mix two or three drops of IFO scattering solution # IF-850005 (not supplied) in the water to make the laser beam barely visible in the cylinder. If we move the cylinder slowly across the lower beam, the internal reflections and refractions will be clearly visible. The intensity of the emerging beam will be found to vary greatly as the angle of incidence between the laser beam and the cylinder is varied.

We can accurately measure angles between the incident and the emerging beams by using long distance techniques with the aid of IFO lasers. This is illustrated in the drawing following, where we wish to find the angle theta (the angle AXR in Newton's illustration).

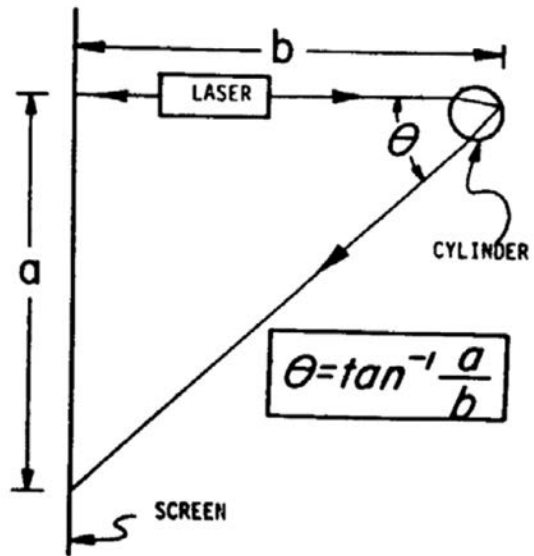

A more complicated project is finding the second order rainbow
 --0-(H,G)-S in Newton's first drawing—try it.

EXPERIMENT 25. REFLECTION

Overview

When light encounters the boundary between two surfaces with different optical densities, some or all of the energy will be reflected. In this investigation we will examine several types of reflection with a laser beam.

Procedure

A. Types of Reflection

1. Investigate the reflective abilities of several different types of materials included in the Optics Education Kit. Materials such as flat mirrors provide specular reflection, which changes the direction of the beam without scattering or diffusing the light. Rough objects such as unpolished metal, paper or wood reflect the light at the same time as they scatter it. Point the laser beam at a variety of solids and liquids, and observe the reflection by holding a piece of glossy paper near the object to catch the reflected light. In each case, record the type of material tested and the appearance of the reflected laser light.

2. Using a microscope slide or the specially designed beam splitter (part # 45-728), investigate the phenomenon of partial reflection as part of a laser beam is transmitted through a material and part of it is reflected at the surface. Observe the relative intensity of the transmitted and reflected portions of the beam as the glass is tilted at various angles to the incident beam. Record your observations.

3. Shine the beam into a tank of water and observe that reflections will take place not only when the beam enters the water, but also when the beam is leaving the water from a different side of the tank. Reflections that tend to keep the laser beam inside of a medium are known as internal reflections. The intensity of the internal reflection depends on the angle that the beam strikes the surface. Set up an experiment to determine the relative amount of internal reflection as the angle between the laser beam and the surface varies.

B. Law of Reflection

The law of reflection states that the angle of incidence is equal to the angle of reflection. It also states that the incident ray, normal ray and reflected ray all lie on the same plane. This can be verified with precision by using the laser and the technique outlined below. The items used for the experiment are also available in the IFO IF-548 Light Ray Viewing Kit.

1. Pour 1.7 liters of warm water (65°C /150 °F) into a clear pan. Add seven drops of IFO scattering solution IF-850005 to the water and stir gently for several seconds.
2. Position the laser on a table so that the beam passes through the solution as shown in the Figure. Center and tape a flat mirror where the spot appears in the back of the pan. Place a protractor in the bottom of the pan and roughly center it beneath the beam as shown.
3. Look down at the pan and adjust the laser so that it enters the tank and hits the flat mirror at an angle as shown. Position the beam stop so the reflected laser beam strikes the beam stop as shown in the Figure.
4. Position the protractor so that the center marking is directly under where the beam hits the flat mirror. Adjust the laser beam until it passes over the 100 degree and center markings of the protractor. Note: This is 10 degrees from a normal drawn through where the laser hits the flat mirror (90 degree marking on protractor). Look at the reflected beam and record the angle marking on the protractor over which it passes.
5. Repeat step 4 but use the 110 degree marking (20 degrees from normal) on the protractor.
6. Review your recorded data. Calculate the angle in degrees away from the 90 degree normal for the incident and reflected rays. According to the law of reflection the incident angle (in degrees away from the normal) should equal the reflected angle.

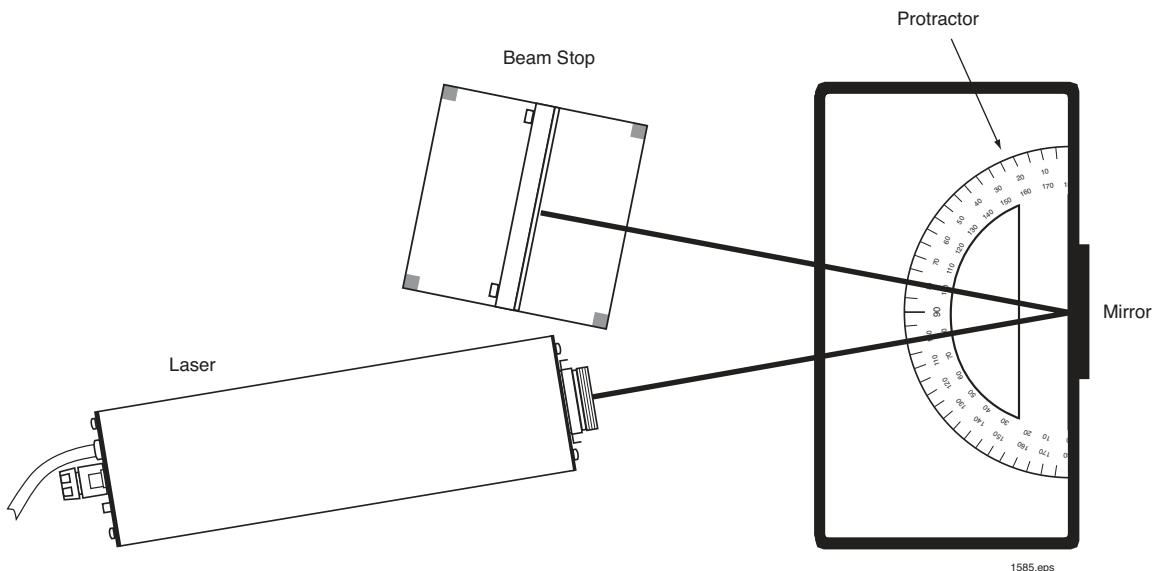

Proving the law of reflection using laser beam and long distance measuring techniques.

EXPERIMENT 26. MEASURING THE CRITICAL ANGLE

Overview

When light travels from any medium into a vacuum, a critical angle of incidence is associated with internal reflections in the material at the boundary with the vacuum. Light rays approaching the boundary at an angle that equals or exceeds this critical angle don't emerge — all of the light will be reflected internally. Measuring the critical angle of a material is easily done using a fine laser beam.

Procedure

The items used for the experiment are also available in the IFO IF-548 Light Ray Viewing Kit.

A. Determine the critical angle of water by adding some to a transparent tank. Add seven drops of IFO scattering solution IF-850005 to the water and stir gently for several seconds. Aim the laser beam into the left side of the tank as shown in the diagram above.

B. Rotate the tank slowly in each direction until the laser beam emerges only from the back of the tank with no reflections inside the tank.

C. Slowly rotate the tank counter-clockwise until the beam just begins to totally reflect inside the tank. Drop a protractor into the tank and measure the angle between the laser beam and the normal to the surface it strikes at the rear of the tank. This is the critical angle for the water.

Note that the acrylic tank contributes an error term to the critical angle measured for the water since it has a different index of refraction. The error is relatively small because the acrylic is fairly thin and its refractive index isn't radically different than water.

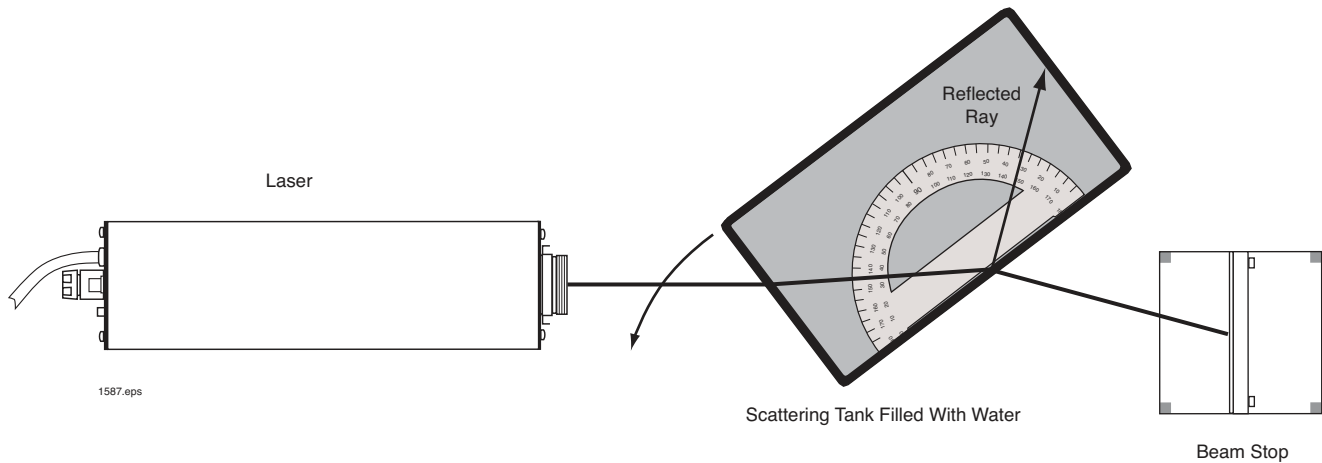

Total internal reflection of the laser beam

EXPERIMENT 27. MEASURING THE INDEX OF REFRACTION OF LIQUIDS

Overview

Because the laser beam is so narrow and bright, it not only provides a ready means for measuring the index of refraction of homogeneous liquids, but also can be used to locate and measure non-homogeneities as well.

Procedure

A. Determine the index of refraction for water by adding some to a transparent tank. Add seven drops of IFO scattering solution IF- 850005 to the water and stir gently for several seconds. Aim the laser beam into the left side of the tank roughly in the center as shown in the diagram above. Using a protractor rotate the tank until the incident angle between the beam and the surface normal where it enters the tank is 30 degrees. Measure the angle between the normal and the refracted ray inside the tank. Calculate the index of refraction of water, using the relationship:

$$n = \frac{\sin i}{\sin r}$$

Where: n = index of refraction

i = angle of incident ray

r = angle of refracted ray

- B. Change the angle of incidence to several different values then calculate the index of refraction of water for each trial.
- C. Substitute a variety of transparent liquids for water and measure the index of refraction of each, following the steps above. Alcohol and glycerin are suitable materials for this investigation.
- D. Investigate the gradual bending of light that occurs when a laser beam is transmitted through a solution in which the optical density is not constant. This can be done by filling the bottom of a fish tank to a depth of 5 to 10 cm with a solution of sugar and water. Try different concentrations of sugar and water.
- E. A technique to investigate the rates of diffusion between two liquids of different indexes of refraction was described by Barnard and Ahlborn (American Journal of Physics, July 1975, p. 573). A cell two inches square containing photographic Rapid Fix was slowly filled to the top with plain water. A beam spreader was attached to the laser to spread the beam into a thin line, making a 45° angle with the vertical. It was passed through the liquid-filled cell and the beam trace observed on a screen on the far side of the cell. As the two liquids diffused over a time of approximately 30 minutes, the shape of the trace changed in a predictable manner. Additional details can be found by referring to this interesting article.

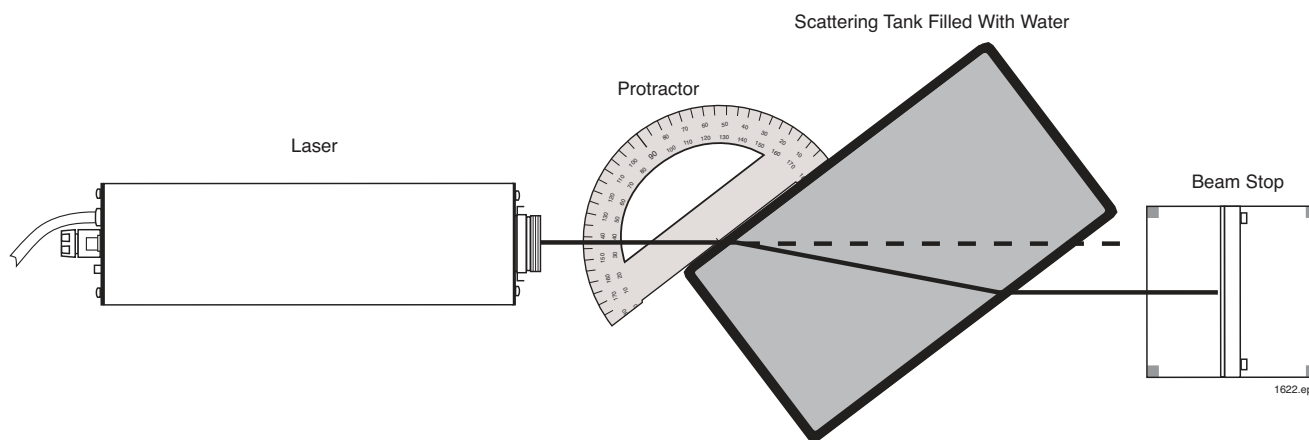

EXPERIMENT 28. DIFFRACTION TECHNIQUE FOR MEASURING INDEX OF REFRACTION

Overview

When entering a new material refracts light, there is also a change in wavelength. The frequency of the light is fixed at the source, but as the speed of light changes in different materials the wavelength also changes. Determining this wavelength change with a diffraction grating provides a novel technique for measuring the index of refraction.

Procedure

- Aim a laser beam into an empty fish tank so the beam is normal (perpendicular) to the surface of the glass. Longer tanks will give better resolution for this measurement.
- Measure the angle that the beam makes between the central maximum and the first order maximum to the left or right of the central point. Calculate the relationship:

$$\lambda_a = d \cdot \sin\theta_a$$

Where: λ_a is the wavelength of the laser beam in the fish tank
 d is the distance between slits in the diffraction grating
 θ_a is the angle between the central maximum and the first order maximum with air in the tank

- Fill the tank with water and notice how the angle θ decreases. The decrease is due to the refraction of the water.
- Calculate λ the wavelength of the laser beam with water in the tank.
- Find the index of refraction of the water by dividing the wavelength found in Step B by the wavelength found in Step D.

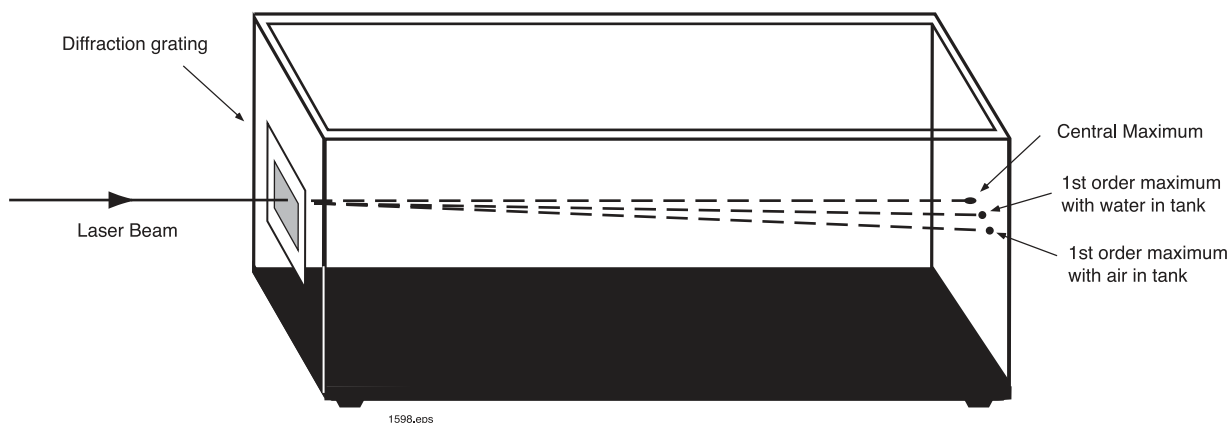

EXPERIMENT 29. DOPPLER EFFECT

Overview

The Doppler effect is a well-known phenomenon where the apparent frequency of waves from a source are changed when the source or observer are in motion. Using the IFO photometer (supplied as an optional accessory), we can readily demonstrate the Doppler effect on light waves.

Procedure

- A. Set up the laser, beam splitter and two front surface mirrors in the manner described in Experiment 13 on the Michelson interferometer. Instead of using a plano-convex lens to display the interference pattern on a screen, superimpose the two reflected beams on the detector of the photometer.
- B. Set the range switch of the photometer to its middle position.
- C. Connect the output of the photometer to any audio amplifier and speaker, using the jack at the side of the photometer for this purpose.

- D. Move one of the front surface mirrors back and forth very slowly. You will hear a tone from the loudspeaker.

The frequency of light is too high to directly produce an audible tone. But when one of the front surface mirrors is moved slowly, there is an apparent change in the wavelength of light in its path. This Doppler shift in wavelength causes movement of the interference fringes generated between the stationary reference beam and the beam affected by the mirror motion. The fringes move at a rate within the audio frequency range, and the amplitude variations are detected by the photodetector and reproduced as sound. The frequency of the sound is directly proportional to the rate at which the mirror is moved. Rapid movements however produce frequency changes higher than the audible range and can't be heard.

- E. Try to devise a mechanical mechanism that can advance one of the mirrors at a uniform speed, to produce a steady tone, or at a variable speed to produce a tone that fluctuates in frequency

ADDITIONAL EXPERIMENTS FOR ADVANCED STUDY

EXPERIMENT 30. SCATTERING OF LIGHT

Overview

Laser beams, like any other light, are invisible to us unless they travel in a direction that enters the eye and falls on the retina. When a laser beam encounters small particles like airborne dust, most of the light is transmitted but some of it is scattered by the particles. This scattered light enables us to “see” the laser beam. Whenever scattering occurs there is also some absorption of the laser beam, which weakens the intensity. Try some of the suggestions for scattering experiments given below. You may wish to design your own scattering experiments. In either case, take careful notes as you proceed.

Procedure

- Shake chalk dust from a blackboard eraser or dry-erase eraser in front of the laser and record the scattering effects that you observe.
- Pour some water into a container and shine a laser beam through the water before the air bubbles have had time to dissipate. Describe the scattering effects you observe as the air bubbles rise and finally disappear.
- Rotate clear ice in front of the laser beam and view the scattering effects that occur when the beam encounters any imperfections in the crystalline structure.
- Shine the laser beam through a transparent tank of clear water and place a photometer on the far side of the tank to measure the output of the laser beam. Add measured amounts of various

chemicals that don't dissolve in water, and stir each time to mix. Make graphs to show the relationship between the chemical concentrations mixed with the water versus readings on the light meter. IFO offers scattering solution IF-850005 that can be used for this experiment.

- Light generally doesn't scatter uniformly in all directions. Using a suitable liquid solution or suspension, place the base of a protractor along the laser beam and observe the amount of light that scatters at various angles with respect to the beam. If a light meter or photometer is available, take quantitative data. On a graph, plot the meter reading versus the scattering angle.
- Observe Rayleigh scattering by using the set-up shown below. Put a few drops of scattering solution in a Florence flask full of water. Polarize the laser beam by placing a polarizing filter over the front of the laser.

With the aid of a mirror, shine the laser beam along the axis of the flask neck and observe the intensity of the light scattered from the flask. With a photometer at a constant distance from the flask, move it in a 360° circle recording the intensity of the scattered light each 10° and plot the result on polar graph paper.

More complex scattering patterns result with a few drops of milk in the flask. Unlike the scattering solution, milk particles are much larger than the wavelength of laser light so the scattering pattern is not as simple as the Rayleigh distribution. But it will be easy to observe by eye that the intensity of the scattered light is not uniform in intensity at the neck of the flask.

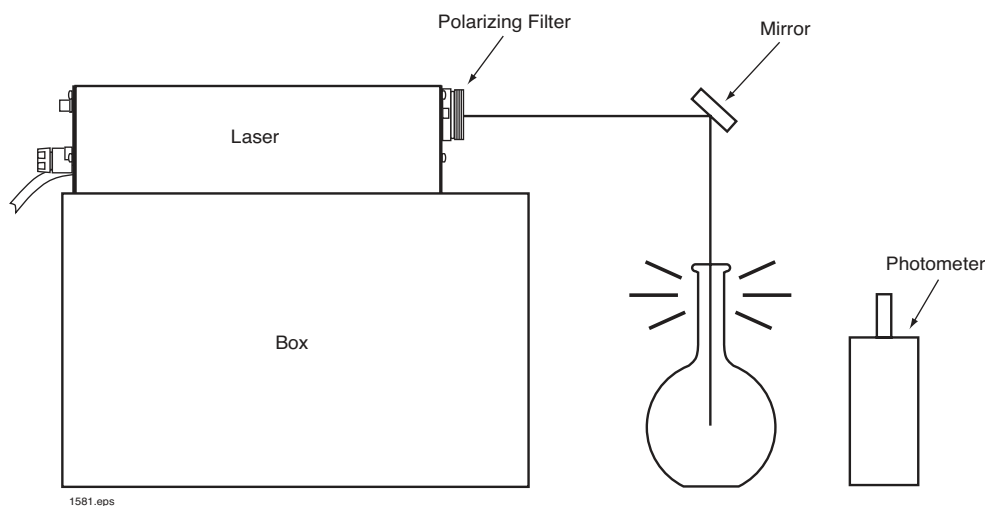

EXPERIMENT 31. MEASURING THE INDEX OF REFRACTION OF A GAS

Overview

Students of introductory physics can easily measure the index of refraction of air or any other gas. When this experiment was popularized by the PSSC Advanced Topics Laboratory, the light source used was a weak mercury lamp. If we substitute a laser as the light source, alignment of the optics is greatly simplified and a bright, real image can be projected on a screen for easy adjustment and viewing by a group of students.

Theory of Operation

As in Experiment 13, a Michelson interferometer is constructed using a beam splitter and two front surface mirrors. One mirror is attached to the end of a gas chamber is evacuated by a vacuum pump. The other mirror is mounted on a gimbal fixture firmly anchored to the triangular optics bench.

By making small adjustments to the two mirrors, the two beams can be superimposed on the screen and a plano-convex lens will expand the display to show alternate dark and bright interference bars, or fringes. Air is removed from the chamber with the vacuum pump. The valve is then opened slightly to let air gradually leak back inside the chamber. As the air re-enters you count either the dark or the bright interference fringes moving across the screen.

Light travels slower in air than it does in a vacuum. This has the same effect as lengthening the optical path through the chamber. Thus, each fringe shift represents an increase in distance equal to one wavelength of light (6328\AA for a He-Ne laser). By comparing the optical path length in the evacuated chamber with the apparently increased length when the chamber is filled with air (or other gas), we can find the index of refraction of the gas:

$$n = \frac{2L + N\lambda}{2L}$$

- Where:
- n = index of refraction
 - N = number of fringes moving across the screen
 - λ = wavelength of light
(6.328×10^{-5} cm for a He-Ne Laser)
 - L = inside length of gas chamber in cm.

(Optical path is $2L$ because light passes through the chamber twice.)

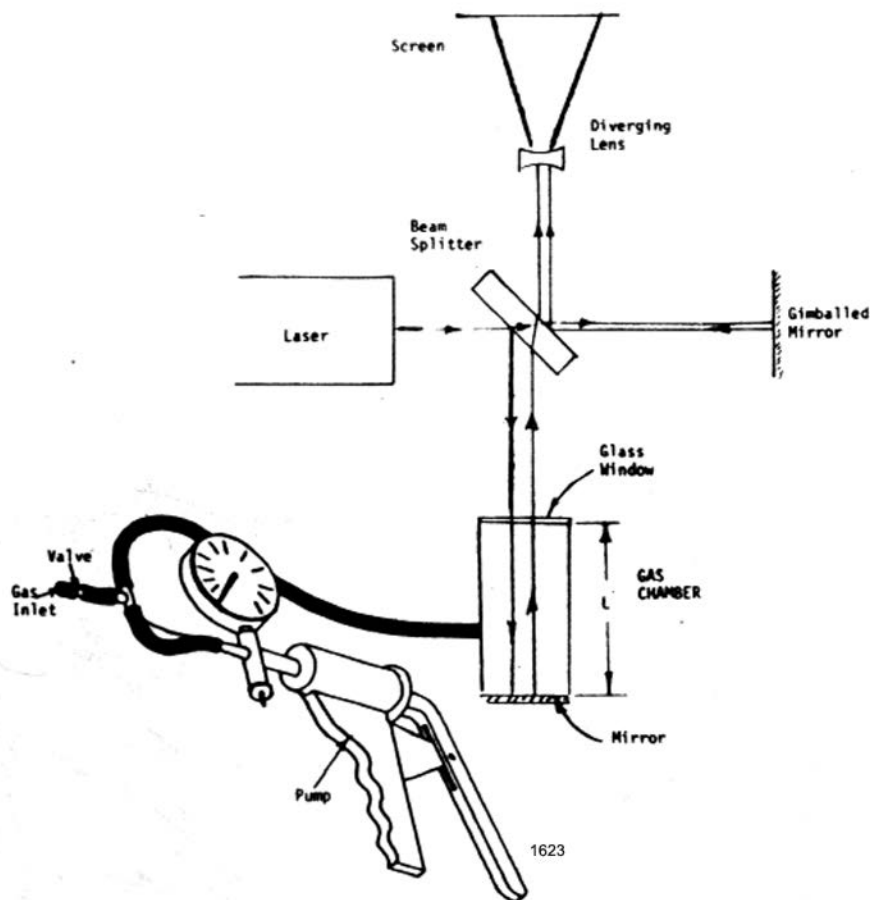

In a typical run, we counted 44 fringes when using a chamber 6.3 cm. long. The index of refraction of air was calculated to be 1.00022, which compares favorably with the handbook value of 1.00029.

Procedure

- A. Mount a laser, Maggie Mount platform and gimbale mirror on the triangular optics bench as shown in the illustration. Attach the laser to the adjustable laser carrier and aim it directly at the mirror in the gimbal mount at the opposite end of the triangular optics bench. If necessary, use the rectangular spacer to raise the laser to the same level as the mirror. The Maggie platform must be screwed into its carrier and firmly mounted on the optics bench.
- B. On the Maggie Mount platform, mount the gas cell, beam splitter and plano-convex lens in the positions shown. Attach the gas cell to a vertical Maggie carrier with an L Maggie carrier below the gas cell to provide additional support. The beam splitter and plano-convex lens also are mounted on vertical Maggie mounts. Adjust the distances between the two mirrors on the platform so they are approximately equidistant from the beam splitter.
- C. Adjust the positions of the beam splitter and the two mirrors so the split laser beams are directed through the plano-convex lens and superimposed on a screen to form an interference pattern of

light and dark fringes. Fine adjustments for clear, heavy fringes are possible with the adjustments on the gimbale mirror and on the adjustable laser carrier.

- D. Close the valve on the vacuum tubing and operate the hand pump to evacuate the air in the gas chamber. From this point, it is essential that you keep the optical components perfectly still – without the slightest movement or vibration. If necessary, clamp the tubing to a firm support such as a bench clamp or a ring-stand.
- E. Very, very slowly, open the vacuum valve and let the air or other gas enter the chamber. As it enters, note that fringes in the interference pattern shift from right to left. Count the total number of fringes that pass a spot in the center of the screen from the time that the valve is opened until the time the pressure gauge indicates that the gas chamber is refilled.
- F. To find the index of refraction of carbon dioxide, hydrogen, or any other common gases that are available in lecture table flasks, evacuate the air from the gas chamber with a vacuum pump and then purge the gas chamber once or twice with the desired gas attached to the gas inlet. When you are certain that no air remains in the chamber or the connecting tubing, operate the apparatus to find the index of refraction of the gas.

EXPERIMENT 32. AMPLIFICATION OF MOVEMENT

Overview

A laser beam is very bright and diverges only a small amount under ordinary laboratory conditions. This makes it an ideal device for optical amplification of small and almost imperceptible mechanical movements. With a little ingenuity, we can invent many original devices by using the principles of optical amplification to solve both practical and scientific problems.

Procedure

A. Laser Galvanometer

1. Wind 20 turns of insulated wire around a cylindrical form such as a screwdriver handle. Remove the screwdriver, tape the coils together, and suspend them from two thin strands of wire attached to the two end tips of the coil. The longer the suspension wires, the more sensitive the galvanometer.

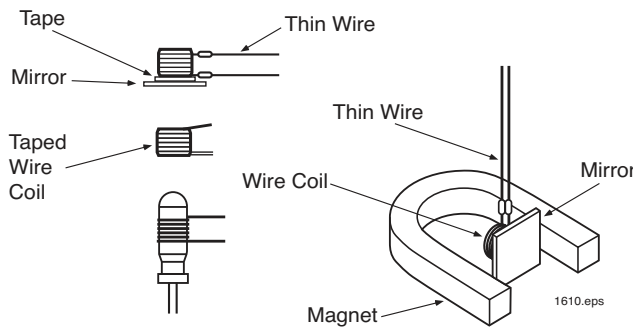

2. Using a small piece of cellulose tape or double-sided tape, fasten the coil to the thin mirror supplied with the Optics Education Kit.
3. Suspend the coil and mirror between the poles of a horseshoe magnet as shown in the diagram.
4. Be careful that the laser beam or its reflection doesn't enter anyone's eyes. Aim the laser at the mirror and observe its reflection on a distant wall. When a small amount of electric current is applied to the coil, the mirror will twist making a large deflection of the laser beam.
5. Using appropriate resistive shunts and multipliers, calibrate the galvanometer to read amperes and volts. A standard ammeter or voltmeter may be used for comparison.

B. Heart Pulse Indicator

1. Fasten a small mirror to your wrist, directly over the point where you feel your heart pulse beat. Adhesive tape will adhere to the skin better than cellulose or electrical tape for this purpose.

2. Be careful that the laser beam and its reflection doesn't enter anyone's eye. Aim the laser at the mirror and observe its reflection on a distant wall.
3. With your wrist held steady on a table, you will see that very small movements of the mirror caused by the pulse beat show up as large deflections on the wall. With care, you can measure the amplitude of the beat as well as the rate.

C. Laser Oscilloscope

Using the principles of optical amplification, we can project Lissajous patterns on a distant wall, and demonstrate the principles of an oscilloscope.

1. Mount two 3-inch radio speakers in a frame as shown in the following diagram.
2. Glue the tip of a wooden dowel to one end of each speaker. Glue the other end of each dowel to thin plastic strips cut from a flexible plastic ruler like the one furnished with the Optics Education Kit
3. Attach the free ends of the plastic strips to the frame and cement the small mirror over the intersection of the plastic strips.
4. Being careful that the laser beam and its reflection do not enter people's eyes, aim the laser at the mirror and observe its reflection on a distant wall.
5. Connect an audio generator to speaker 1 and another audio oscillator to speaker 2. By adjusting the frequencies of each audio oscillator, we can produce a variety of large Lissajous patterns on the wall. Speaker 1 produces horizontal deflections of the beam, and speaker 2 produces vertical deflections.

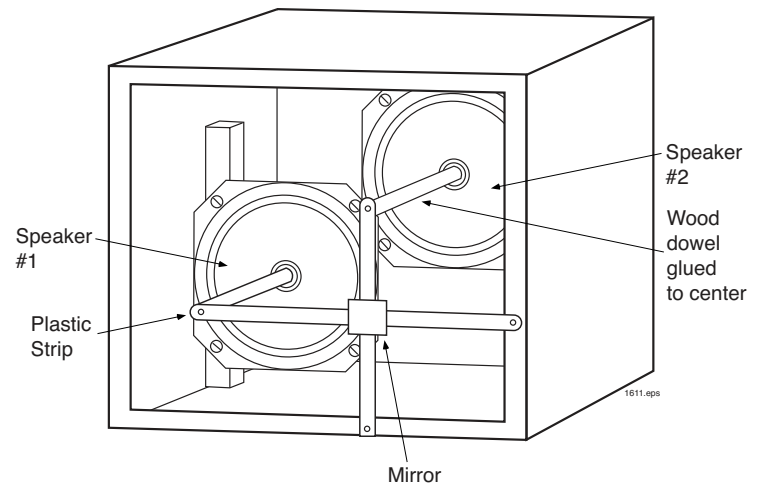

EXPERIMENT 33. ALIGNMENT

Overview

Many helium-neon lasers are used as alignment tools. For instance, many high-powered lasers emit light in the ultraviolet and infrared regions just outside of human visibility. Without a visible reference, it becomes extremely time consuming to place lenses, spatial filters, beam splitters and mirrors in the path of such high power lasers. The helium-neon laser solves the alignment problem quite handily. Its red gleam clearly indicates the light path and allows lenses and other optical components to be properly positioned.

The IFO Optics Set can be used to provide alignment practice.

Begin by making two or more target cards. Each should have a small hole through which the beam can pass.

A. Align the axes of optics benches to a parallel line in space.

1. Align the laser beam with the most distant bench first. As a good safety practice, place a beam stop at the far end of the work area. Place the target on the far end of that bench. Swing and tilt the laser until the beam is centered on the target.
2. Slide the target to the near end of the bench farthest from the laser. Adjust this end of the bench, being careful not to disturb the far end, until the beam is centered on the target.
3. Move the target toward the far end of the bench again, making small adjustments in bench height until the beam remains on target as the target is moved along the entire length of the bench.

More benches can be added. Adjust the newest (closest to the laser) bench only, being careful not to disturb the laser or the first (furthest) bench.

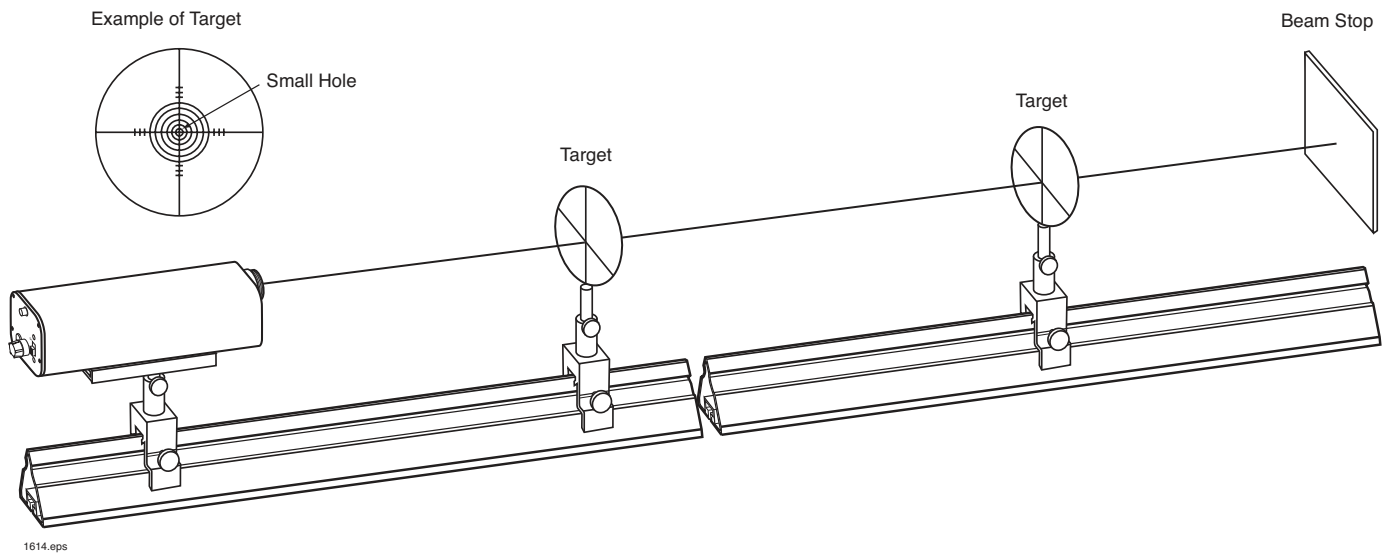

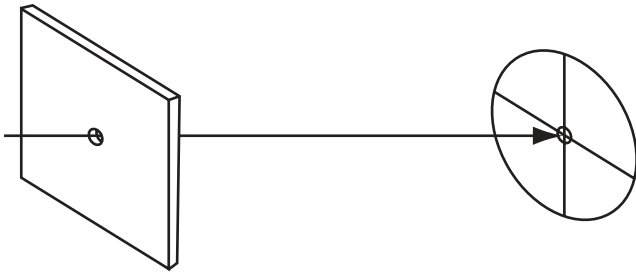

Figure 1. Beam centered on target.

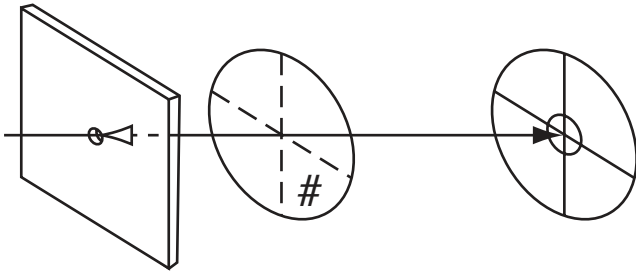

Figure 2. Lens added, centered, squared on.

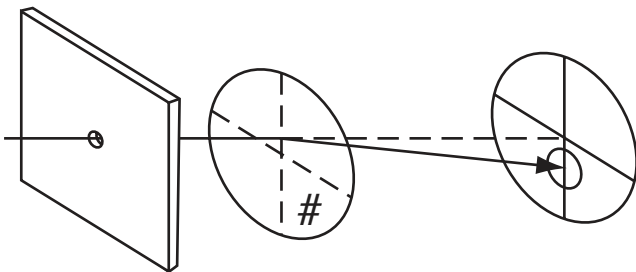

Figure 3. Lens not centered.

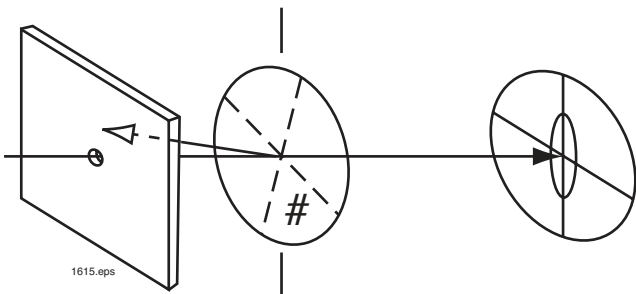

Figure 4. Lens not squared on.

B. Align the lenses. Lenses and other elements may be centered and squared-on (perpendicular to the beam axis) using the laser. Generally, the least effort is needed if conjugates are set from the image furthest back; then other elements are roughly aligned; then alignment is completed using the laser. Make use of the shape and position of both the reflected and transmitted beams in centering and squaring lenses. Figures 2 to 5 show typical conditions.

1. Figure 2. With no lens in the system, center a target on the beam. The beam should be round.
2. Figure 3. With lens in place, centered and squared-on:
 - a. The transmitted beam remains centered and round, although its size may change.
 - b. The reflected beam returns along the same path from which it came. It may be necessary to center a small aperture some distance in front of the beam in order to check this.
3. Figure 4. If the lens is square on but not centered, the transmitted beam will move off center.
4. Figure 5. If the lens (or mirror) is not squared-on:
 - a. The reflected beam is deviated.
 - b. The transmitted beam may not be round.

Generally, 3 and 4 occur simultaneously, so you may need to adjust for both. After you center a lens, it may be necessary to place a target in front of it, center the target, then center and square the next lens forward. Repeat this procedure until all lenses are in position.

Practice will demonstrate that different arrangements may require variations on these procedures.

- C. To align a folded system of almost any configuration, set up small apertures centered on beam as described in Step A. Introduce plane mirrors at appropriate points. Center mirrors to beam, tilt to proper orientation. It may be necessary to make small, multiple movements to keep beam centered while mirror is being tilted.

Derived from an experiment
 contributed by Martin Dvorin
 Optical Technology Department
 Monroe Community College
 Rochester, New York 14623

EXPERIMENT 34. MEASURING THE SPEED OF LIGHT

Overview

Because light can travel about seven and a half times around the earth in one second, measurements of this speed in the student lab have been very difficult. Now, with low-cost He-Ne lasers that can be modulated at radio frequencies, and low-cost, high frequency photodetectors, students can make measurements that rival those of Fizeau and Michelson. Once the basic technique has been mastered, other open-ended experiments can be performed under a variety of environmental conditions.

This experiment can be performed outdoors in a wide-open area or between buildings that are at least 120 meters apart. The best time of day is early morning or evening, when wind and thermal air currents are at a minimum.

Note: As an alternative, the speed of light measurement can now be made in the classroom (over a distance of 20 meters) with the ML-868 modulated laser. Set-up and take down time is only a few minutes. Results can be displayed and easily understood with a dual channel oscilloscope. This IFO “Speed of Light/Laser Audio Kit” is part # 45-720. See the rear of this manual for details about the modulated laser and the kit.

For our outdoor demonstration, in addition to the lenses and mirrors included in the Optics Education Kit, you will need two photodetectors and a modulatable He-Ne laser. (The experiment can be performed with one photodetector, but it’s easier with two.) You’ll also need an oscilloscope with 1 MHz bandwidth and 50-100 mV/cm sensitivity, along with an RF signal generator capable of frequencies from a few kHz to 1 MHz.

The RF signal generator is connected to a low power (1mW) modulatable He-Ne laser and varies the amplitude of the beam at frequencies up to 1MHz. A simple collimates the beam to produce a uniform spot about 2cm in diameter. Part of the beam is directed by a beam splitter (or small mirror) into a photodetector. This photodetector produces a reference signal that will be displayed on the oscilloscope.

Most of the laser light travels to an adjustable mirror approximately 120m away and reflects back through a Fresnel lens to the other photodetector. The output of this photodetector is also fed to the oscilloscope. If the amplitudes of the two beams are equal, and if the longer beam arrives at the photodetector one-half wavelength after the reference beam, complete destructive interference occurs. This causes the waveform on the oscilloscope to disappear.

To create this interference, we make the traveled path 240 meters longer than the reference beam path. Then we increase the frequency from the signal generator from zero until we see a null on the oscilloscope. The null indicates that the distant beam is arriving one half wavelength after the reference beam. Since the frequency of the signal generator is known, it is easy to calculate the time delay that produces the half wavelength shift. We then divide the distance by the time, which gives us the speed of light.

In a sample run outdoors in full daylight, the adjustable mirror was placed 120 meters away. A null was produced when we set the signal generator at 600 kHz. The period of this signal is $1/(6 \times 10^5)$ sec (1.67 μ s). The travel time for a half-wavelength is $\frac{1}{2} \times 1.67 \mu$ s or 0.83 μ s. Dividing the total distance, 240m, by the travel time gives the speed of light as 2.89×10^8 m/sec.

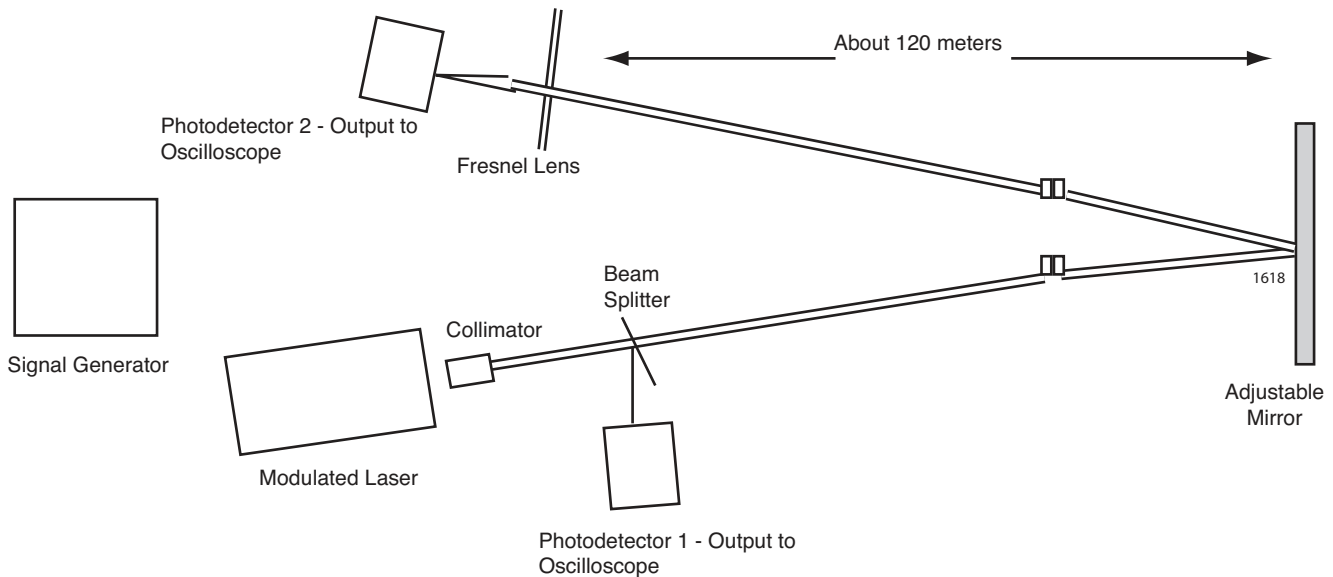

Procedure

1. Connect the output of an RF signal generator to the connector at the rear of the laser. Any standard RF signal generator will do, but it is essential to use a laser that can be modulated at radio frequencies.
 2. Collimate and expand the laser to produce a beam about 2cm in diameter. This can be done with a converging and plano-convex lens system. Test the collimation by holding a screen in front of the laser and checking that the beam diameter remains constant at distances up to 50 meters away.
 3. Divert part of the beam into a photodetector with a small mirror or beam splitter. Connect the photo-detector output to the oscilloscope. Check that the signal generator is modulating the laser beam by observing the photodetector's waveform as the generator frequency is changed.
 4. Project the rest of the beam to the distant mirror and couple the reflected beam onto the second photodetector with the Fresnel lens. This task is more difficult if you are using only one photodetector. The return beam must be reflected by another mirror before passing through the Fresnel lens. It may take students a few hours to align the system because of the distances involved.
- You may have better luck in the early evening or in a long school corridor. IFO's Speed of Light Kit (45-720) comes with adjustable and fixed mirrors, mountings and other accessories for rapid alignment.
5. Adjust the amplitudes of the two photodetector signals to produce waveforms of equal height on the oscilloscope using the vertical controls. If you use only one photodetector, the signals can be balanced by partially masking the mirror that reflects the more intense beam.
 6. Start at the lowest frequency setting and slowly increase the frequency of the signal generator. At low frequencies, the two beams are almost in phase and will interfere constructively, producing a combined signal of relatively high amplitude. As the frequency increases, the relative phase shift increases and the amplitude of the waveform on the oscilloscope decreases. When the two signals are exactly 180° out of phase, they will produce a null, and only a straight horizontal line appears on the oscilloscope. Record the frequency at which this happens and calculate the speed of light according to the calculation outlined above.

NOTES:

ADDITIONAL INDUSTRIAL FIBER OPTICS EDUCATION LABS

45-688 Physical Optics Lab

See the results of optical transformations and Fresnel and Fraunhofer diffraction. Dissect a diffraction pattern using masks. Create a continuous-tone photograph from a halftone. Filter unwanted data from a photograph. Change spatial frequency.

Components include three mounted lenses, two mounted front surface mirrors, non-steel "L" mounts to hold optical components, a 15 mm focal length lens in a threaded cell, a Mylar® viewing screen, a set of 24 transparencies, book, magnetic strips and a fitted storage box. The mounting systems allow for X, Y and Z-axis positioning for all lenses and mirrors. Shipping weight 6 lbs.



IF-LSL-1 Speed of Light/Receiver Project

This kit contains Universal Laser Receiver IF-510 and the necessary optics to measure the speed of light when used with a modulated laser.

The receiver contains a stable 1 MHz oscillator and two photodetectors so separate signals can be electronically displayed on an oscilloscope, greatly reducing set-up time. Given a corner-to-corner distance in a large classroom (20 meters), a modulated laser will yield about a 0.15 microsecond phase delay, which can be measured with a dual channel oscilloscope. With this kit it is possible to make an accurate reading of the speed of light within the classroom.

Included in the kit are an optical beam splitter, first-surface mirror, converging lens, optics mounts, microphone, Universal Laser Receiver with a stable 1 MHz oscillator, 110 VAC-to-DC power adapter, optics table and step-by-step instruction book. Not included but required for operation are a modulated laser and a dual-channel 40 MHz oscilloscope. We will substitute 220 VAC adapters upon request.



Laser Communications Kit

45-920 w/ML211 laser pointer

45-921 w/ML215 laser pointer

IFO presents an updated version of its popular Laser Communications kit. Now with a 5 MHz receiver you can transmit audio, and quality black-and-white color video. Use this kit to bring modern technology to your classroom by teaching the principles of light-based transmission. This kit provides a laser pointer modulator allowing you to modulate either of IFO's pointers.

The kit works by receiving light from a distant audio or video modulated laser. It detects, amplifies and reproduces voice, music, or video communications. An output is provided for a video monitor to reproduce pictures.

Included in the Communications Kit are a modulator, pointer holder, receiver, high impedance microphone, optical platform, three U-shaped Maggie Mounts and easily understood instruction manual. For the 45-920 kit add a ML211 3 mW class IIIA laser pointer (675 nm) and for the 45-921 kit add a ML215 3mW class IIIA laser pointer (635 nm).

Note: Not included but required for operation are a video camera or VCR and monitor.

Michelson Interferometer

45-940 w/ML211 laser pointer

45-941 w/ML215 laser pointer

45-942 without laser pointer

This kit contains a set of optical components and mountings for easy assembly of a Michelson interferometer. This is a classic device for splitting a beam of monochromatic light into two parts that travel along different optical paths and then merge again to produce interference fringes. The fringes shift noticeably in response to even almost imperceptible movement of one of the optical components. They also will shift when the effective length of one optical path changes slightly with respect to the second. These shifts make it possible to measure changes of a medium's index of refraction and microscopic movements of components.

The Michelson Kit includes four U-shaped carriers, two L-shaped carriers, two magnetic strips, a short-focal-length lens, laser pointer holder and instruction manual. For the 45-940, add a ML211 3 mW class IIIA laser pointer (675 nm), and for the 45-941 add a ML215 3 mW class IIIA laser pointer (635 nm).



IFO HARD-SEAL LASER LINE

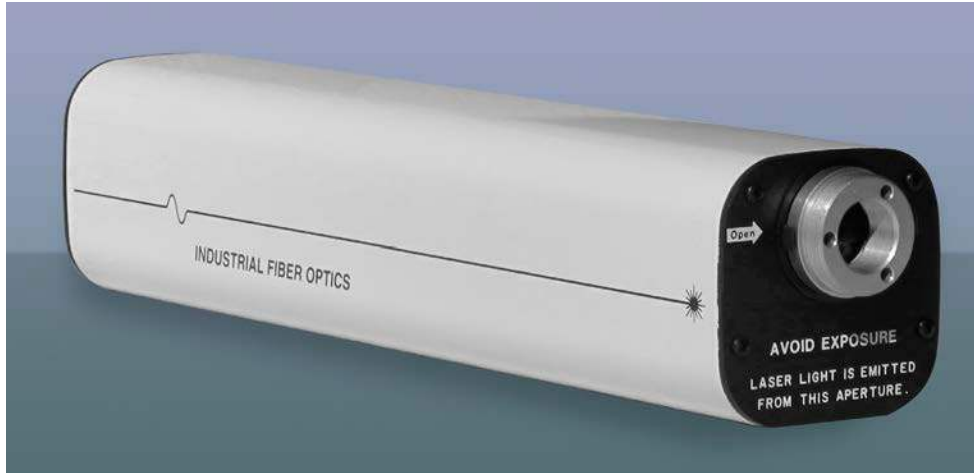

ML-810 0.8 mW Laser (Hard-Seal)

The ML-810 is a favorite of our technical staff who recommend it for many applications. Rated at 0.8 mW, the laser is excellent for conducting hundreds of demonstration, alignment, process control, and measurement functions. A certified Class II Laser, the ML-810 is ideal for both classroom and factory use.

All IFO He-Ne Hard-Seal lasers produce a bright narrow beam of red light (633 nm wavelength) that diverges minimally with distance.

Increased Power

IFO offers the high power laser model ML-840 to satisfy industrial, laboratory, and research needs. Both models include Hard-Seal construction to assure long-lasting, increased power output. IFO recommends consulting the U.S. Bureau of Radiological Health standards before ordering any lasers above 2.0 mW for educational or student environments.

Modulated Lasers

ML-868 0.8 mW 15% Modulated (Hard-Seal)

ML-869 1.5 mW 15% Modulated (Hard-Seal)

Perform all the functions of an ordinary laser and more. Carry information on a laser beam, transmit voice, encode the beam with a tone signal or measure the speed of light within classroom confines. The ML-868 is ideal for classroom use. The ML-869 offers increased power for specific needs and is recommended for research.

On the rear and plate of each laser two connectors permit a source signal to drive the laser. A miniature phone jack may be used for signals with 100 mV peak-to-peak signal level and at least 8,000 ohms impedance. The signal source can be a microphone, signal generator, camcorder, tape recorder or digital camera.

The modulation bandwidth ranges from 50 Hz to 1 MHz (3 dB.). Instructions are included with each laser. The ML-868 and ML-869 include IFO's long-life, Hard-Seal laser tube. Shpg wt. 10 lbs.

CLEANING INSTRUCTIONS

Before sub-assembly and/or installation in the Optics Box, clean the following components with tissues and the solvents indicated.

1. Clean the following parts only with water:

PART	CATALOG NUMBER
Lens	45-631
Lens	45-657
Lens	45-654
Lens	45-652

2. Clean the following parts only with Methyl Alcohol, optics grade:

PART	CATALOG NUMBER
Air Film Wedge	45-661
Mirrors 2 pcs	45-646
Polished Beam Splitter	45-728
Prism	45-726

All parts should be dried with tissues immediately after cleaning to avoid spotting.