

Features

- Dual PWM control circuitry
- Operating voltage can be up to 50V
- Adjustable Dead Time Control (DTC)
- Under Voltage Lockout (UVLO) protection
- Short Circuit Protection (SCP)
- Variable oscillator frequency: 500KHz Max
- 2.5V voltage reference output
- SOP-16L package
- Lead Free Finish/RoHS Compliant for Lead Free products (Note 1)

General Description

The AP2001 integrates Pulse-width-Modulation (PWM) control circuit into a single chip, mainly designed for power-supply regulator. All the functions included are an on-chip 2.5V reference output, two error amplifiers, an adjustable oscillator, two dead-time comparators, UVLO, SCP, DTC circuitry, and dual common-emitter (CE) output transistor circuit.

Recommend the output CE transistors as pre-driver for Driving externally. The DTC can provide from 0% to 100%. Switching frequency can be adjustable by trimming RT and CT. During low V_{CC} situation, the UVLO makes sure that the outputs are off until the internal circuit is operating normally.

Applications

- Backlight inverter
- DC/DC converts in computers, etc.

Ordering Information

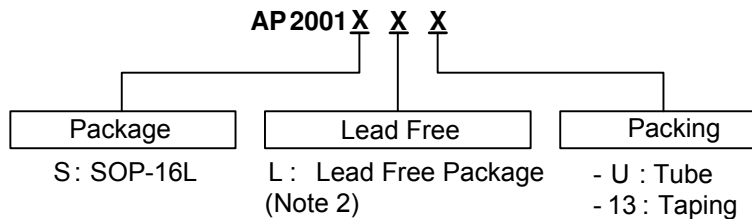

Note: 1. RoHS revision 13.2.2003. Glass and High Temperature Solder Exemptions Applied, see *EU Directive Annex Notes 5 and 7*.

Device	Package Code	Packaging (Note 2)	Tube		13" Tape and Reel	
			Quantity	Part Number Suffix	Quantity	Part Number Suffix
 AP2001S	S	SOP-16L	50	-U	2500/Tape & Reel	-13

Note: 2. Pad layout as shown on Diodes Inc. suggested pad layout document AP02001, which can be found on our website at <http://www.diodes.com/datasheets/ap02001.pdf>.

Pin Assignments

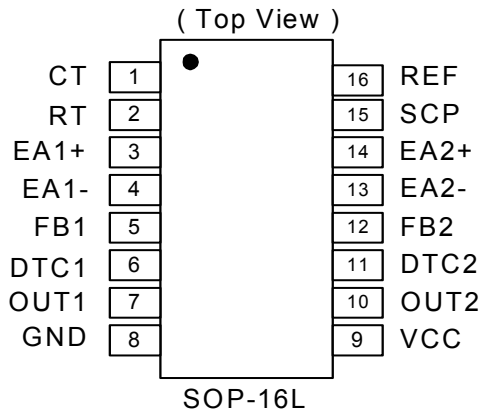

Pin Descriptions

Name	Description
CT	Timing Capacitor
RT	Timing Resistor
EA+	Error Amplifier Input(+)
EA -	Error Amplifier Input(-)
FB	Feedback Loop Compensation
DTC	Dead Time Control
OUT	Pre-driver Output
GND	Ground
VCC	Supply Voltage
SCP	Short Circuit Protection
REF	Voltage Reference

Block Diagram

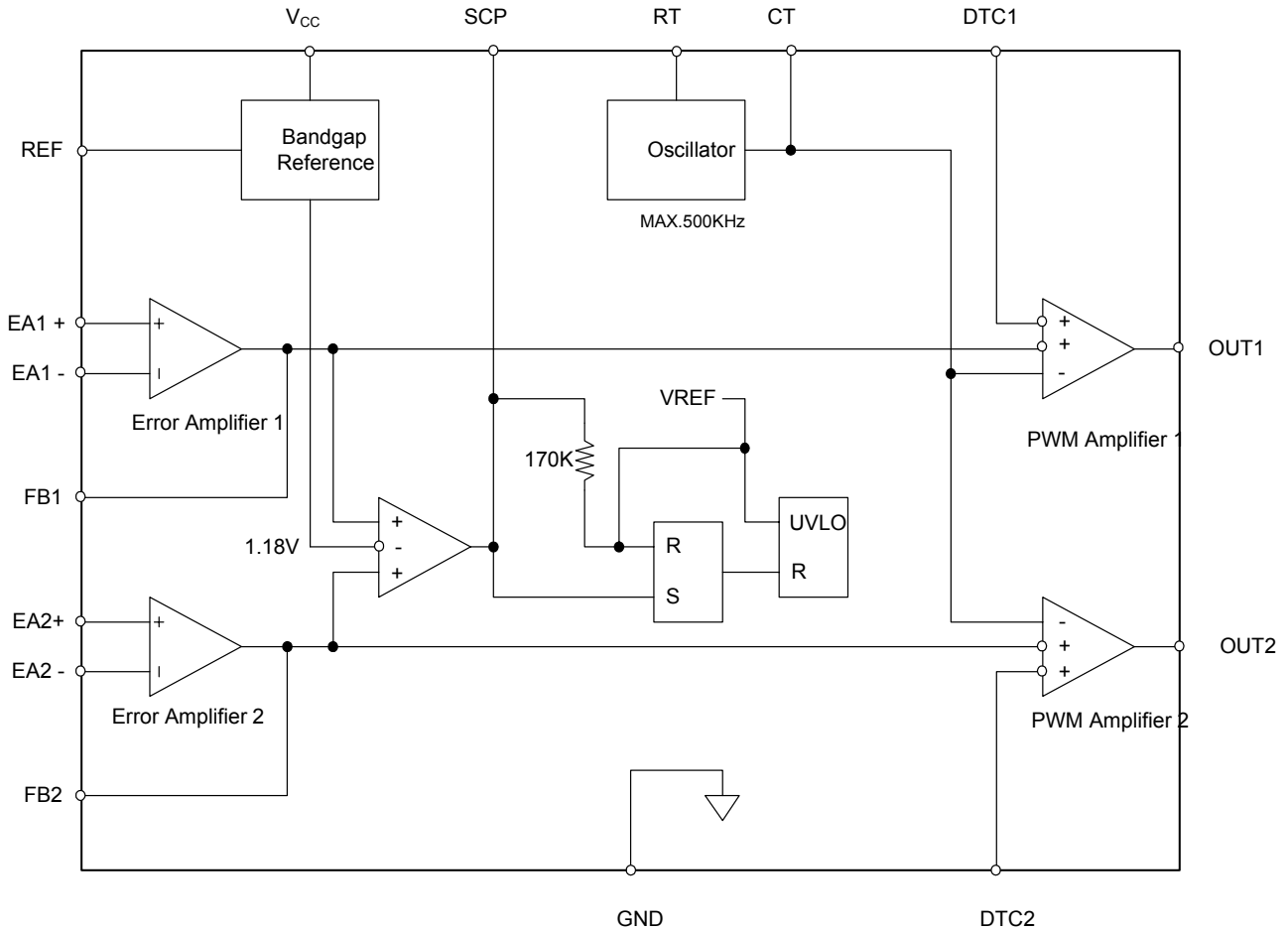

Absolute Maximum Ratings

Symbol	Parameter	Rating	Unit
V _{CC}	Supply Voltage	40	V
V _I	Amplifier Input Voltage	20	V
V _O	Collector Output Voltage	40	V
I _O	Collector Output Current	21	mA
T _{OP}	Operating Temperature Range	-20 to +85	°C
T _{ST}	Storage Temperature Range	-65 to +150	°C
T _{LEAD}	Lead Temperature 1.6 mm (1/16 inch) from Case for 5 Seconds	245	°C

Recommended Operating Conditions

Symbol	Parameter	Min.	Max.	Unit
V_{CC}	Supply Voltage	3.6	40	V
V_I	Amplifier Input Voltage	1.05	1.45	V
V_O	Collector Output Voltage		40	V
I_O	Collector Output Current		20	mA
I_{FB}	Current into Feedback Terminal		45	μ A
R_F	Feedback Resistor	100		k Ω
C_T	Timing Capacitor	150	15000	pF
R_T	Timing Resistor	5.1	100	k Ω
F_{OSC}	Oscillator Frequency	1	500	KHz
T_{OP}	Operating Free-air Temperature	-20	85	$^{\circ}$ C

Electrical Characteristics ($T_A = 25^{\circ}$ C, $V_{CC} = 6$ V, $f = 200$ KHz)

Reference (REF)

Symbol	Parameter	Conditions	Min.	Typ.	Max.	Unit
V_O	Output Voltage (pin 16)	$I_O = 1$ mA	2.4	2.5	2.6	V
	Output Voltage Change with Temperature	$T_A = -20^{\circ}$ C ~ 25° C		-0.1	± 1	%
		$T_A = 25^{\circ}$ C ~ 85° C			-0.2	± 1
V_{DLI}	Input Stability	$V_{CC} = 3.6$ V ~ 40V		2	12.5	mV
V_{DLO}	Output Stability	$I_O = 0.1$ mA ~ 1mA		1	7.5	mV
I_O	Short-circuit Output Current	$V_O = 0$	3	10	30	mA

Under voltage lockout (UVLO)

Symbol	Parameter	Conditions	Min.	Typ.	Max.	Unit
V_{UT}	Upper Threshold Voltage (V_{CC})	$I_{O(REF)} = 0.1$ mA $T_A = 25^{\circ}$ C		2.65		V
V_{LWT}	Lower Threshold Voltage (V_{CC})			2.45		V
V_{HT}	Hysteresis (V_{CC})		80	200		mV

Electrical Characteristics (Continued)
Short-circuit protection (SCP) control

Symbol	Parameter	Conditions	Min.	Typ.	Max.	Unit
V_{IT}	Input Threshold Voltage	$T_A = 25^\circ\text{C}$	0.65	0.7	0.75	V
V_{STB}	Standby Voltage	No pull up	140	185	230	mV
V_{LT}	Latched Input Voltage	No pull up		60	120	mV
I_{SCP}	Input (Source) Current	$V_I = 0.7\text{V}, T_A = 25^\circ\text{C}$	-10	-15	-20	μA
V_{CT}	Comparator Threshold Voltage (FB)			1.18		V

Oscillator (OSC)

Symbol	Parameter	Conditions	Min.	Typ.	Max.	Unit
F_{OSC}	Frequency	$C_T = 330\text{ pF}, R_T = 10\text{ K}\Omega$		200		KHz
ΔF_{OSC}	Standard Deviation of Frequency	$C_T = 330\text{ pF}, R_T = 10\text{ K}\Omega$		10		%
	Frequency Change with Voltage	$V_{CC} = 3.6\text{V} \sim 40\text{V}$		1		
	Frequency Change with Temperature	$T_A = -20^\circ\text{C} \sim 25^\circ\text{C}$ $T_A = 25^\circ\text{C} \sim 85^\circ\text{C}$		-0.4 -0.2	± 2 ± 2	

Dead-time control (DTC)

Symbol	Parameter	Conditions	Min.	Typ.	Max.	Unit
I_{BDT}	Input Bias Current				1	μA
I_{DT}	Latch Mode (Source) Current	$T_A = 25^\circ\text{C}$	-80	-145		
V_{DT}	Latched Input Voltage	$I_O = 40\mu\text{A}$	2.3			V
V_{T0}	Input Threshold Voltage at $f = 10\text{ KHz}$	Zero duty cycle		2.05	2.25	
V_{T100}		Maximum duty cycle	1.2	1.45		

Error-amplifier

Symbol	Parameter	Conditions	Min.	Typ.	Max.	Unit
V_{IO}	Input Offset Voltage	$V_O (\text{FB}) = 1.25\text{V}$			± 6	mV
I_{IO}	Input Offset Current	$V_O (\text{FB}) = 1.25\text{V}$			± 100	nA
I_{IB}	Input Bias Current	$V_O (\text{FB}) = 1.25\text{V}$		160	500	nA
V_{CM}	Common-mode Input Voltage Range	$V_{CC} = 3.6\text{V} \sim 40\text{V}$	1.05 to 1.45			V
A_V	Open-loop Voltage Amplification	$R_F = 200\text{ K}\Omega$	70	80		dB
GBW	Unity-gain Bandwidth			1.5		MHz
CMRR	Common-mode Rejection Ratio		60	80		dB
V_{OH}	Max. Output Voltage		$V_{ref}-0.1$			V
V_{OL}	Min. Output Voltage				1	V
I_{OI}	Output (Sink) Current (FB)	$V_{ID} = -0.1\text{V}, V_O = 1.25\text{V}$	0.5	1.6		mA
I_{OO}	Output (Source) Current (FB)	$V_{ID} = 0.1\text{V}, V_O = 1.25\text{V}$	-45	-70		μA

Electrical Characteristics (Continued)

Output section

Symbol	Parameter	Conditions	Min.	Typ.	Max.	Unit
I_{LEAK}	Leakage Current	$V_O = 40V$			10	μA
V_{SAT}	Output Saturation Voltage	$I_O = 10\text{ mA}$		1.2	2	V
I_{SC}	Short-circuit Output Current	$V_O = 6V$		90		mA

PWM comparator

Symbol	Parameter	Conditions	Min.	Typ.	Max.	Unit
V_{T0}	Input Threshold Voltage at $f = 10\text{ KHz (FB)}$	Zero duty cycle		2.05	2.25	V
V_{T100}		Maximum duty cycle	1.2	1.45		V

Total device

Symbol	Parameter	Conditions	Min.	Typ.	Max.	Unit
I_{CCS}	Standby Supply Current	Off-state		2.5	3.0	mA
I_{CCA}	Average Supply Current	$R_T = 10\text{ K}\Omega$		2.8	3.5	mA

Typical Application Circuit

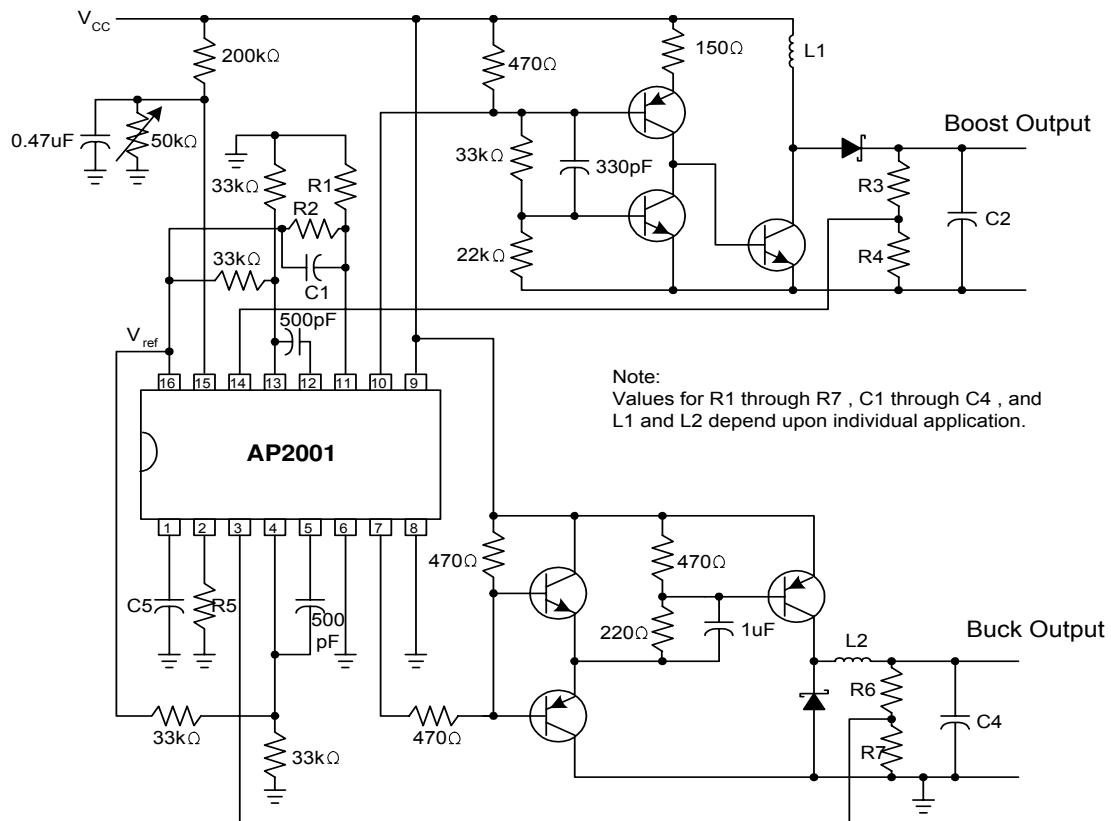

Dual output DC/DC converter

Marking Information

(1) SOP-16L

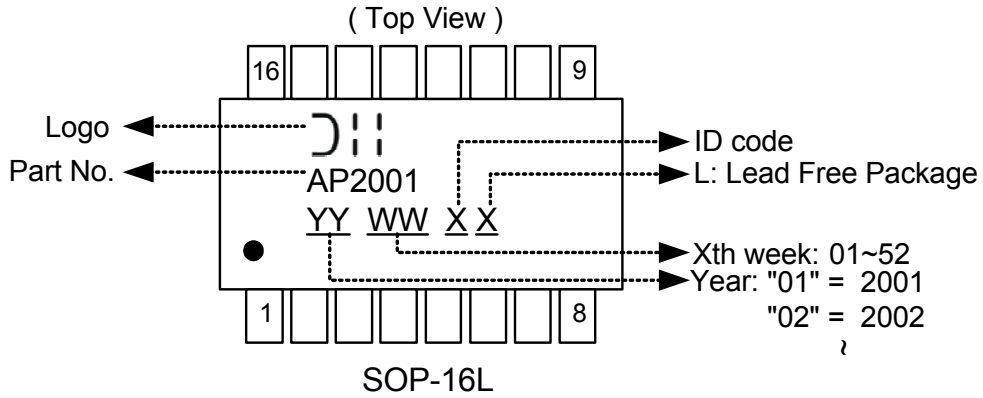

Package Information

(1) Package Type: SOP-16L

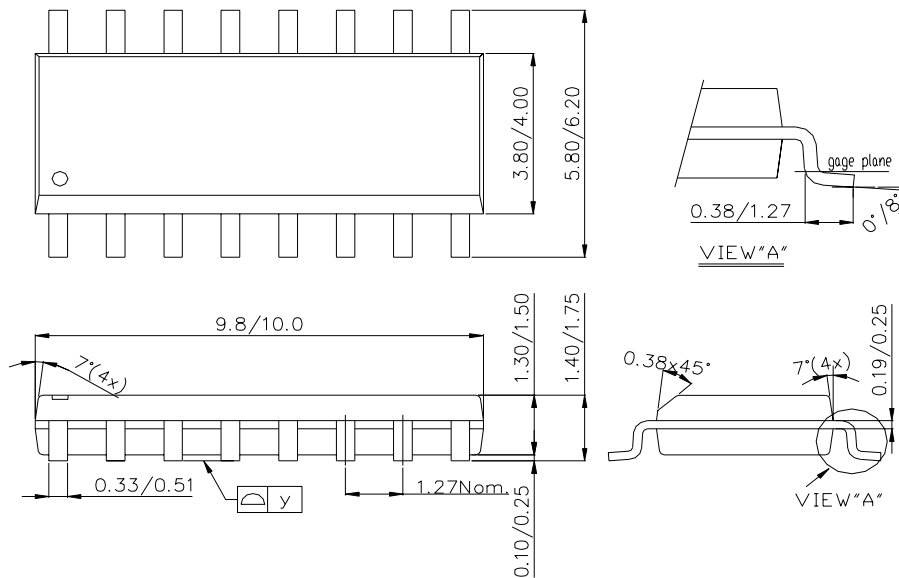

IMPORTANT NOTICE

Diodes Incorporated and its subsidiaries reserve the right to make modifications, enhancements, improvements, corrections or other changes without further notice to any product herein. Diodes Incorporated does not assume any liability arising out of the application or use of any product described herein; neither does it convey any license under its patent rights, nor the rights of others. The user of products in such applications shall assume all risks of such use and will agree to hold Diodes Incorporated and all the companies whose products are represented on our website, harmless against all damages.

LIFE SUPPORT

Diodes Incorporated products are not authorized for use as critical components in life support devices or systems without the expressed written approval of the President of Diodes Incorporated.