

REV.	DATE	ECR NO.	DESCRIPTION
NC	01/29/03	XXXXXX	INITIAL RELEASE
A	02/24/12	2283	ADD RECOMMENDED MOUNTING HOLE

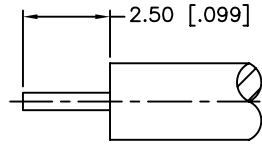

RECOMMENDED
CABLE STRIPPING DIM'S

RECOMMENDED
MOUNTING HOLE

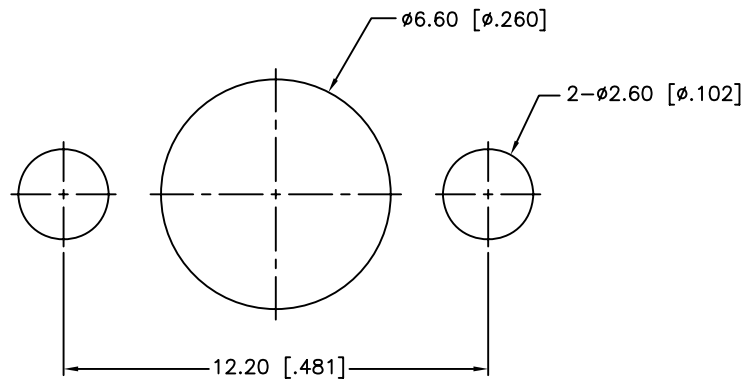
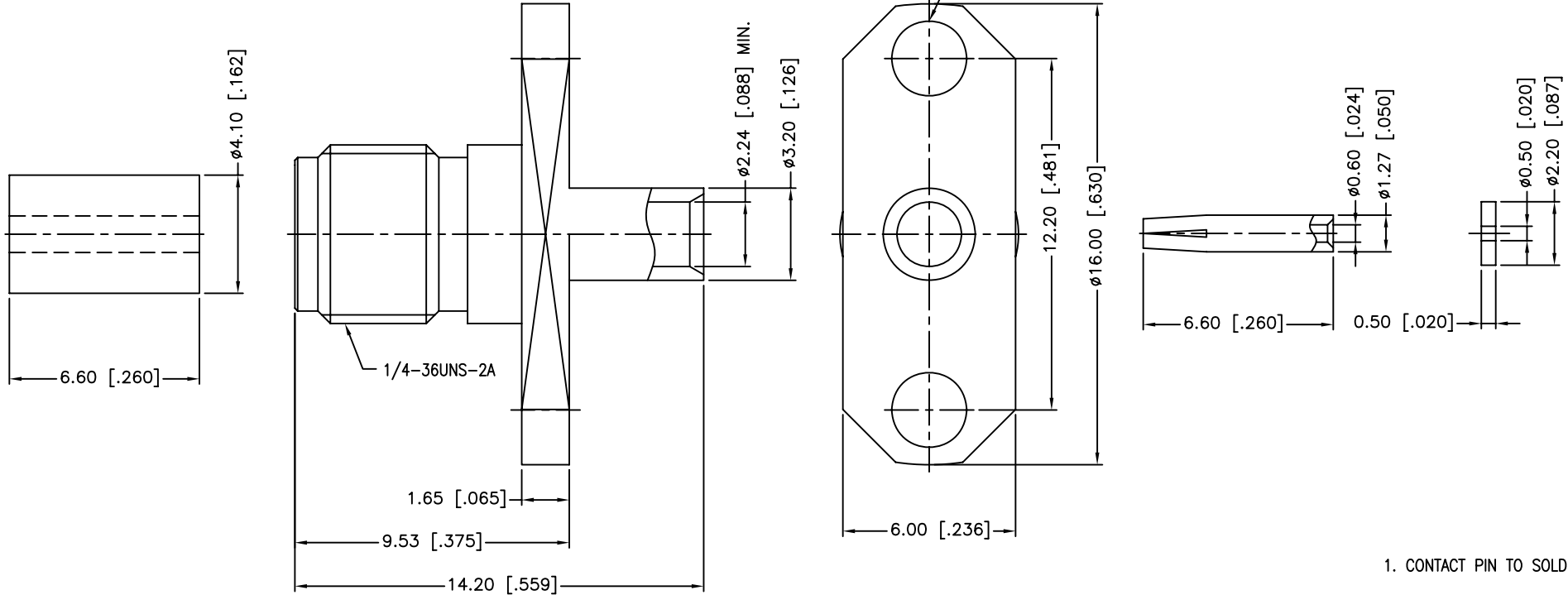

1. CONTACT PIN TO SOLDER

QTY	DESCRIPTION	MATERIAL	FINISH
4	INSULATOR	PTFE	NATURAL
3	CONTACT PIN	BER. COPPER	GOLD
2	INSULATOR	PTFE	NATURAL
1	BODY	BRASS	GOLD

UNLESS OTHERWISE SPECIFIED DIMENSIONS ARE IN MILLIMETERS. DIMENSIONS IN [] ARE IN INCHES AND FOR CUSTOMER REFERENCE ONLY.

UNLESS OTHERWISE SPECIFIED TOLERANCES FOR MILLIMETERS ARE:
0.5 - 8mm ± 0.20mm
8 - 30mm ± 0.40mm
30 - 120mm ± 0.50mm

UNLESS OTHERWISE SPECIFIED TOLERANCES FOR INCHES ARE:
.020 - .315 = ± 0.007"
.315 - 1.180 = ± 0.015"
1.180 - 4.724 = ± 0.020"

DO NOT SCALE DRAWING

APPROVALS	DATE
DRAWN M.ZHANG	02/24/12
CHECKED	
ISSUED	
SHEET 1 OF 1	
CAD FILE C:/CONNEX/132109.DWG	

Amphenol Connex

PART DESCRIPTION
**SMA SEMI-RIGID PANEL JACK
(FOR .085", .086" CABLE)**

PART NO. **132109**

DWG. NO. 132109.DWG REV. A SIZE A SCALE NA