

# UD info Corp.

## Industrial M.2 2280 PCIe SSD M2P-80DC Series Product DataSheet

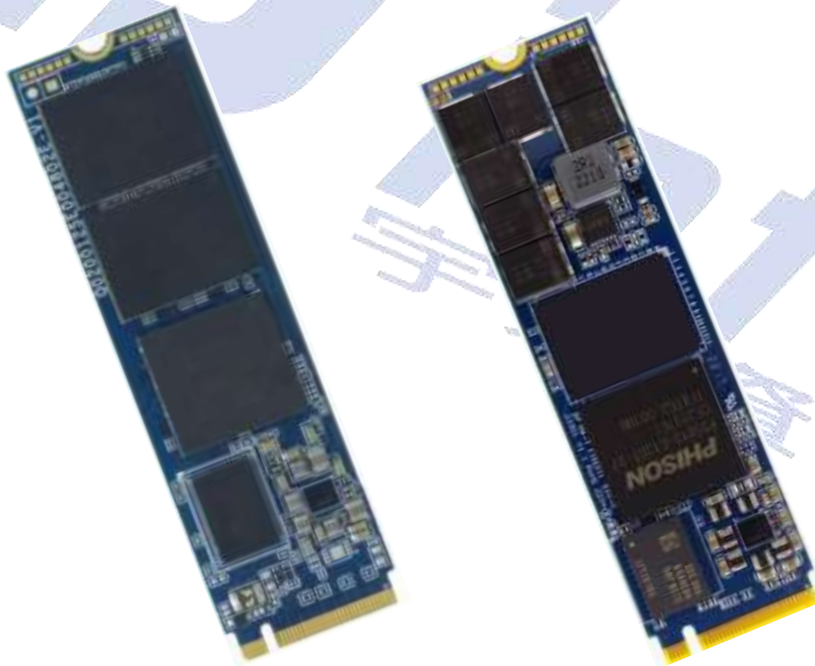

© 2022 UD INFO Corp. All right reserved.

Specifications are subject to change without prior notice.

3F-4, No.8, Ln. 609, Sec. 5, Chongxin Rd., Sanchong Dist., New Taipei City 241, Taiwan (R.O.C.)

TEL: +886-2-7713-6050 FAX: +886-2-8511-3151

E-mail: [sales@UDinfo.com.tw](mailto:sales@UDinfo.com.tw)

<b>1.</b>	<b>Introduction .....</b>	<b>6</b>
1.1.	General Description .....	6
1.2.	Block Diagram .....	6
<b>2.</b>	<b>Product Specifications.....</b>	<b>7</b>
2.1.	Product Specifications.....	7
2.2.	Device Capacity .....	7
2.3.	Performance .....	8
2.4.	POR/SPOR Standby Ready Time .....	9
2.5.	Thermal Throttling .....	10
2.6.	TCG Opal 2.0 .....	12
<b>3.</b>	<b>Environmental Specifications .....</b>	<b>13</b>
3.1.	Environmental Conditions .....	13
3.1.1.	Temperature Specification .....	13
3.1.2.	Mechanical Specification .....	13
3.1.3.	Electrostatic Discharge (ESD) .....	13
3.1.4.	EMI Compliance .....	14
3.2.	TBW (Terabytes Written) .....	14
3.3.	UBER (Uncorrectable Bit Error Rates) .....	15
3.4.	MTBF.....	15
<b>4.</b>	<b>Electrical Specifications .....</b>	<b>16</b>
4.1.	Supply Voltage.....	16
4.2.	Power Consumption.....	16
<b>5.</b>	<b>Interface.....</b>	<b>17</b>
5.1.	Pin Assignment and Descriptions .....	17
<b>6.</b>	<b>Supported Commands.....</b>	<b>20</b>
6.1.	NVMe Command List.....	20
6.2.	Identify Device Data .....	22
6.3.	SMART Attributes .....	28
<b>7.</b>	<b>Physical Dimension .....</b>	<b>29</b>
<b>8.</b>	<b>Terminology .....</b>	<b>31</b>

**9. Barcode Description ..... 31**  
**10. Partnumber Decoder ..... 32**



## Revision History

Revision	Draft Date	History	Author
1.0	2019/5/22	New release	Golden Lee
1.1	2019/8/20	Update capacity support & performance / power consumption	Golden Lee
1.2	2019/10/28	Update performance & TBW	Golden Lee
1.3	2020/3/19	Update Wide Temperature support for 2TB	Golden Lee
1.4	2021/4/28	Added B16 support	Golden Lee
1.5	2021/8/25	Add Bics4 and PLP function support	Golden Lee
1.6	2021/10/1	New format	Golden Lee
1.7	2022/8/19	Added BiCS5 support	Golden Lee
1.8	2022/11/17	Modify BiCS4 960GB Flash structure	Golden Lee
1.9	2023/3/29	Removed safety certification	Golden Lee



## Product Overview

- **Capacity**
  - 240GB up to 1920GB
- **Form Factor**
  - M.2 2280-M
- **PCIe Interface**
  - NVMe PCIe Gen3 x4
  - NVMe 1.3d
  - PCI Express Base 3.1
- **Flash Interface**
  - 3D TLC BGA
  - Up to 4pcs of BGA152 flash
- **Performance**<sup>Note1</sup>
  - Read up to 3,300 MB/s
  - Write up to 1,000 MB/s
- **Power Consumption**<sup>Note2</sup>
  - Active mode: < 6,000 mW
  - Idle mode: < 2,000 mW
- **Reliability**
  - MTBF: 2 million hours
  - UBER<sup>Note5</sup> < 1 sector per 10<sup>16</sup> bits
- **ECC**
  - LDPC / RAID ECC
  - Low density parity check code  
( >120bit/KBytes )
- **Temperature Range**<sup>Note3</sup>
  - Operation Temperature:
    - Standard: 0°C ~ 70°C
    - Wide: -40°C ~ 85°C
  - Storage Temperature: -40°C ~ 85°C
- **RoHS Compliant**
- **EMI Compliant**
  - EN55032, CISPR 32 (CE)
  - AS/NZS CISPR 32 (CE)
  - ANSI C63.4 (FCC)
  - CNS 13438 (BSMI)
  - VCCI-CISPR 32 (VCCI)
- **Features Support List**
  - TCG Pyrite/OPAL<sup>Note4</sup>
  - Thermal throttling
  - SmartECC™
  - SmartRefresh™
  - Write Protect
  - Secure Erase
- **Hardware Power Loss Protection Support**

### Notes:

1. Refer to Chapter 2 for more details.
2. Refer to Chapter 4, section 4.2 power consumption for more details.
3. The operation temperature means the case temperature, in which can be detected via the S.M.A.R.T.
4. Support by different production settings and firmware version.
5. Uncorrectable Bit Error Rate (UBER)

# 1. INTRODUCTION

## 1.1. General Description

UDinfo's M.2 2280 PCIe solid state Drive delivers all the advantages of flash disk technology with PCIe Gen3 x4 interface and is fully compliant with the standard Next Generation Form Factor (NGFF) called M.2 Card Format. The M.2 2280 could provide a wide range capacity up to 1920GB and its performance can reach up to 3,300MB/s read and 1,000MB/s write. Moreover, the power consumption of the M.2 2280 is much lower than traditional hard drives, making it the best embedded solution for new platforms.

## 1.2. Block Diagram

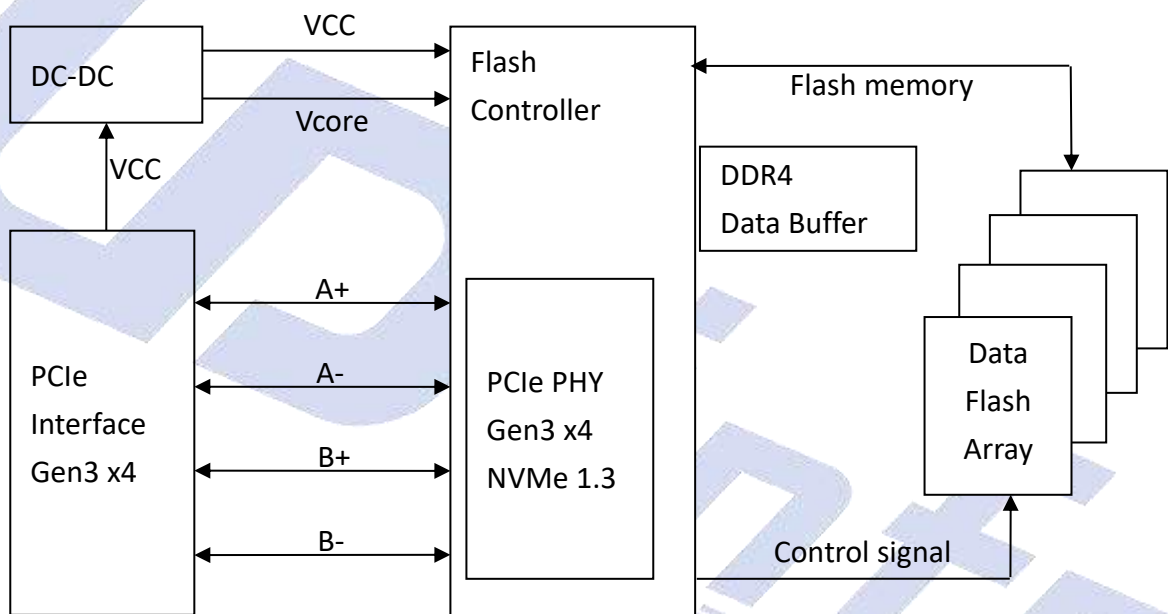

**M.2 2280 PCIe SSD Block Diagram**

## 2. PRODUCT SPECIFICATIONS



### 2.1. Product Specifications

- **Capacity**
  - 240GB up to 1920GB
- **Electrical/Physical Interface**
  - PCI Express Base Ver 3.1
  - Compliant with NVMe 1.3d
  - PCIe Gen3 x 4 lane & backward compatible to PCIe Gen2 and Gen1
- **Support Hardware Power Loss Protection (Optional)**
  - Protect data loss, even the last data, during write process when power sudden off.
  - Add-on Polymer Tantalum Capacitors hold-up several milliseconds to keep DRAM data write to NAND Flash.

### 2.2. Device Capacity

Capacity	IDEMA Standard		User Data Size
	512Bytes/Sector	4KBytes/Sector	
	Total Sectors (LBA)	Total Sectors (LBA)	
240GB	468,862,128	58,607,766	Depended on file management
480GB	937,703,088	117,212,886	
960GB	1,875,385,008	234,423,126	
1920GB	3,750,748,848	468,843,606	

**Notes:**

1. 1 Gigabyte (GB) is equal to 1,000,000,000 Bytes; 1 sector is equal to 512 Bytes.
2. The calculation is following IDEMA Standard.
3. The total actual user data size of the SSD may be less than device capacity due to SSD format, SSD partition, operating system.

EX: OS shows 223.57GB (NTFS) with 240GB SSD.

## 2.3. Performance

Capacity	Flash Structure	Sequential		4K Random	
		Read (MB/s)	Write (MB/s)	Read (IOPS)	Write (IOPS)
240GB	64GB x4, BGA BiCS3, DDP	2,800	340	101K	13K
480GB	128GB x4, BGA BiCS3, QDP	3,000	580	170K	18K
960GB	256GB x4, BGA BiCS3, ODP	2,600	1,000	200K	20K
1920GB	512GB x4, BGA BiCS3, ODP	2,500	900	200K	20K
240GB	64GB x4, BGA BiCS4, DDP	3,300	360	110K	11K
480GB	128GB x4, BGA BiCS4, QDP	3,300	580	200K	15K
960GB	256GB x4, BGA BiCS4, ODP	3,300	1,000	200K	24K
1920GB	512GB x4, BGA BiCS4, ODP	3,300	1,000	200K	24K
240GB	128GB x2, BGA BiCS5, DDP	1,400	160	50K	35K
480GB	128GB x4, BGA BiCS5, DDP	3,300	350	100K	80K
960GB	256GB x4, BGA BiCS5, QDP	3,300	750	200K	160K
1920GB	512GB x4, BGA BiCS5, ODP	3,300	1,000	200K	200K

**Notes:**

1. Performance may differ according to flash configuration and platform.
2. Performance specification is under Thermal Throttling inactivated.
3. The data shows the sustained and average performance.
4. Performance is measured with the follow conditions
  - (a.) CrystalDiskMark 7.0, 1GB range, QD32T1 for sequential
  - (b.) FIO on Linux version with QD32 for IOPS
  - (c.) OS: Win10 64bit was, version 1709
  - (d.) Intel Core i7-8700K CPU @ 3.70GHz
5. Measurement environment: Room temperature: 20~25°C, humidity: 40~60%RH, DC+3.3V condition.



## 2.4. POR/SPOR Standby Ready Time

- POR/SPOR Ready Time

Capacity	POR ready time		SPOR ready time	
	Typ.	Max.	Typ.	Max.
240GB	120	180	2,000	8,000
480GB	120	180	3,000	8,000
960GB	120	180	3,500	8,000
1920GB	120	180	3,500	8,000

Unit: ms

**Notes:**

1. POR/SPOR stands for following:
  - (a.) POR: Power On Ready. (The ready time variation depends on data recover size.)
  - (b.) SPOR: Power On Ready after Sudden Power Off. (The ready time variation depends on data recover size.)
2. POR/SPOR ready time stands for following:  
Power on Time: From Power On to SSD response after drive ready.
3. Measurement environment: Room temperature: 20~25°C, humidity: 40~60%RH, DC+3.3V condition.

## 2.5. Thermal Throttling

The purpose of thermal throttling is to prevent any components in a SSD from over-heating during read and write operations. The controller is designed with an on-die thermal sensor and with its accuracy, firmware can apply different levels of throttling to achieve the purpose of protection efficiently and proactively via S.M.A.R.T. reading.

- **Purpose of Thermal Throttling:**
  - In order to keep the optimal performance in the safe range of the temperature.
- **Thermal sensors:**
  - We have external thermal sensor & on-die thermal sensor (internal controller) to detect temperature. There is 1pcs external thermal sensor on PCB, the position depends on different form factor (The thermal sensor is shown below. The picture is for reference only).
  - External thermal sensor would detect flash temperature; On-die thermal sensor detect controller temperature.

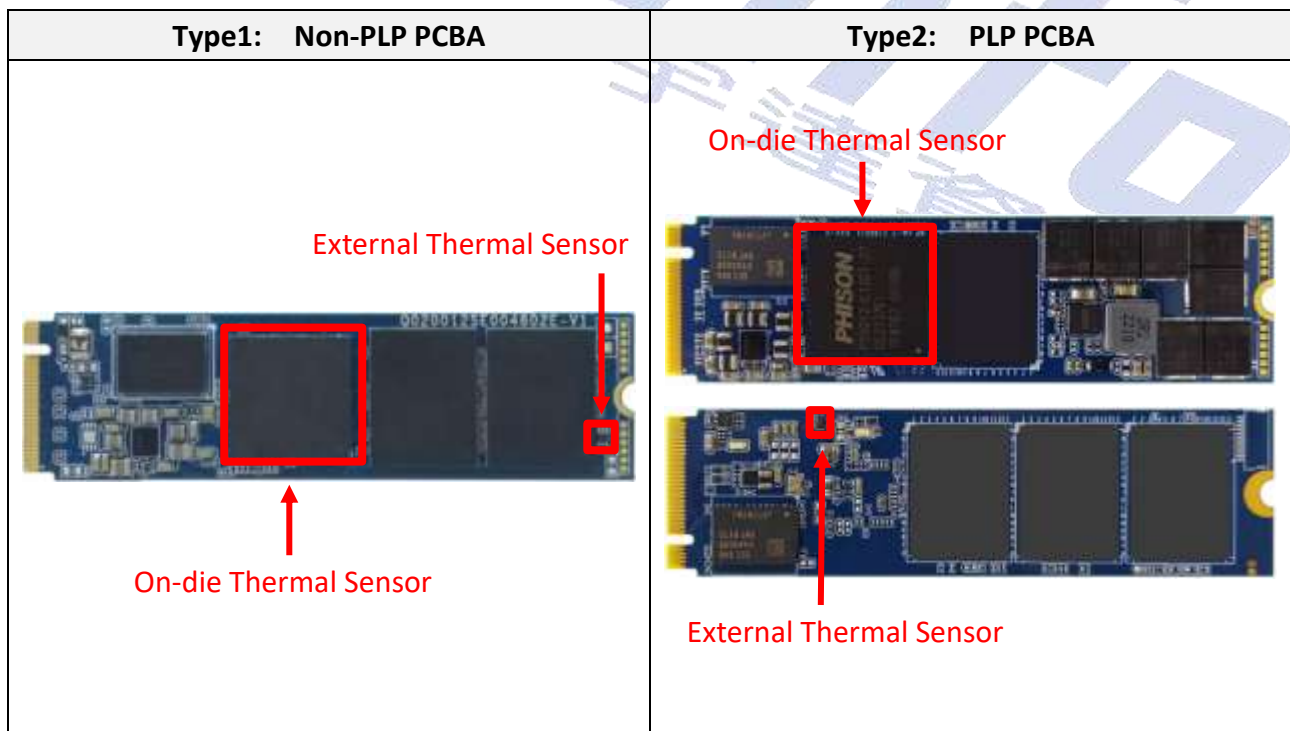

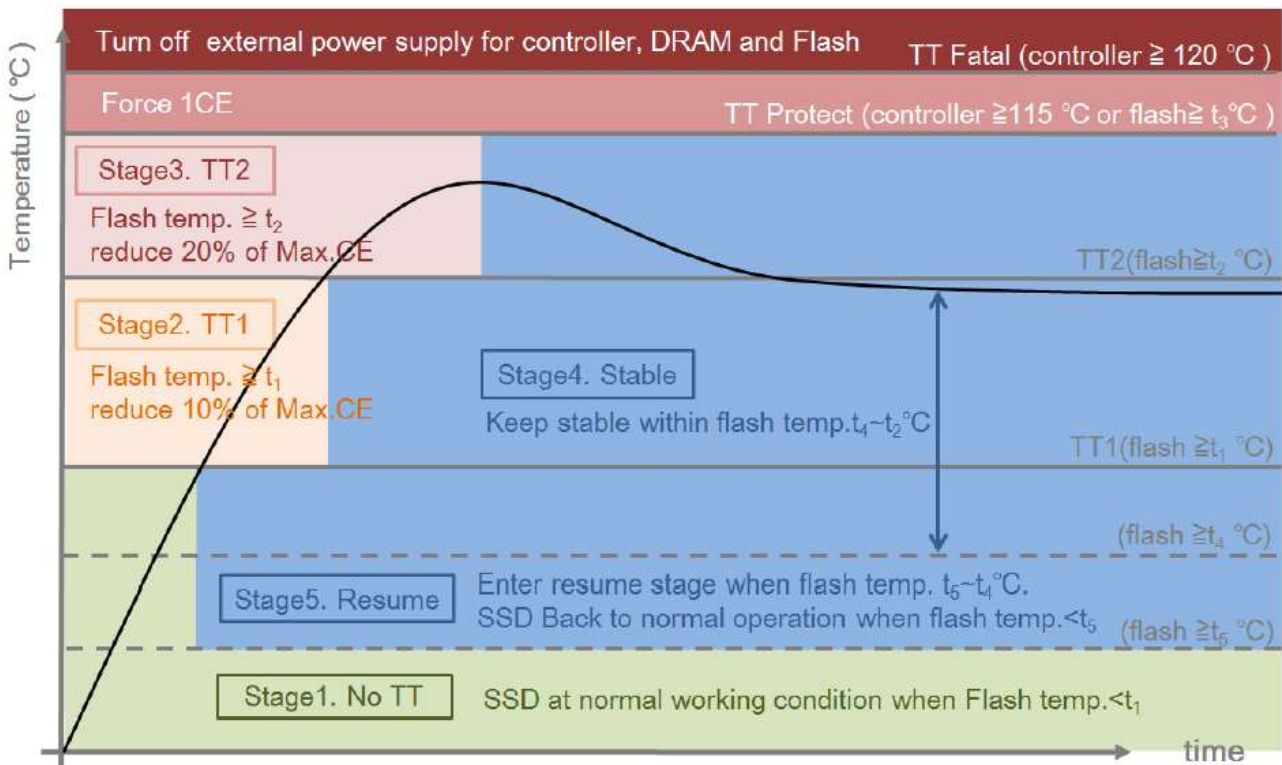

**Figure 2-1 Thermal Throttling Schematic**

	Operation temp. of Normal-temp. grade: 0-70°C	Operation temp. of Wide-temp. grade: -40-85°C
<b>t<sub>1</sub></b>	68°C	82°C
<b>t<sub>2</sub></b>	70°C	85°C
<b>t<sub>3</sub></b>	80°C	95°C
<b>t<sub>4</sub></b>	64°C	78°C
<b>t<sub>5</sub></b>	60°C	74°C

**Notes:**

1. TT shown on Figure 2-1 means “Thermal Throttling”.
2. CE = Chip Enable.
3. temp. = temperature

## 2.6. TCG Opal 2.0

The Opal specification is a set of specifications for self-encrypting drives published by the Trusted Computing Group (TCG), a non-profit organization that develops, defines, and promotes standards and specifications for secure computing. The Opal Security Subsystem Class(SSC) 2.0 defines the details of data management in storage devices and the classes authority for data access, and secures data from theft and tampering by unauthorized persons who are able to gain access to the storage device or host system.

### TCG Opal 2.0 Main Features:

- AES 256-bit Hardware Self Encryption
- Deploy Storage Device & Take Ownership:  
The Storage Device is integrated into its target system and ownership transferred by setting or changing the Storage Device's owner credential.
- Activate or Enroll Storage Device:  
LBA ranges are configured and data encryption and access control credentials (re)generated and/or set on the Storage Device. Access control is configured for LBA range unlocking.
- Lock & Unlock Storage Device:  
Unlocking of one or more LBA ranges by the host and locking of those ranges under host control via either an explicit lock or implicit lock triggered by a reset event. MBR shadowing provides a mechanism to boot into a secure pre-boot authentication environment to handle device unlocking.
- Repurpose & End-of-Life:  
Erasure of data within one or more.
- Physical Presence SID (PSID):  
PSID is defined by TCG OPAL as a 32-character string and the purpose is to revert SSD back to its manufacturing setting when the drive is still OPAL-activated. PSID code can be printed on a SSD label when an OPAL-activated SSD supports PSID revert feature.

### 3. ENVIRONMENTAL SPECIFICATIONS



#### 3.1. Environmental Conditions

##### 3.1.1. Temperature Specification

	Mode	Min.	Max.	Unit
Temperature Ranges	Operation (Standard)	0	70	°C
	Operation (Wide)	-40	85	°C
	Storage	-40	85	°C
Humidity	Operation	5	95	%
	Storage	5	95	%
Temperature Cycle Test	Operation (Standard)	0	70	°C
	Operation (Wide)	-40	85	°C
	Storage	-40	85	°C

**Notes:**

- The operation temperature means the case temperature, in which can be detected via the S.M.A.R.T. Airflow is suggested and it will allow device to be operated at appropriate temperature for each component during heavy workloads environment.

##### 3.1.2. Mechanical Specification

Items			Condition
<b>Shock</b>	Non-operational	Acceleration Force	1500G 0-p with half sine wave (0.5ms)
<b>Vibration</b>	Non-operational	Frequency/Displacement	20Hz~80Hz/1.52mm
		Frequency/Acceleration	80Hz~2000Hz/20G p-p with sine wave
<b>Drop</b>	Non-operational	Height of Drop	80cm free fall
		Number of Drop	6 face of each unit
		Conflicting Material	Concrete floor

##### 3.1.3. Electrostatic Discharge (ESD)

Specification	+/- 4KV
EN 55024, CISPR 24 EN 61000-4-2 and IEC 61000-4-2	Device functions are affected, but EUT will be back to its normal or operational state automatically.

### 3.1.4. EMI Compliance

EMI Compliance
EN 55032, CISPR 32 (CE)
AS/NZS CISPR 32 (CE)
ANSI C63.4 (FCC)
VCCI-CISPR 32 (VCCI)
CNS 13438 (BSMI)

### 3.2. TBW (Terabytes Written)

Capacity	Flash Type	TBW	DWPD
240GB	64GB x4, BGA BiCS3, DDP	390	0.8
480GB	128GB x4, BGA BiCS3, QDP	800	0.8
960GB	256GB x4, BGA BiCS3, ODP	1,580	0.8
1920GB	512GB x4, BGA BiCS3, ODP	3,150	0.8
240GB	64GB x4, BGA BiCS4, DDP	270	0.6
480GB	128GB x4, BGA BiCS4, QDP	580	0.7
960GB	256GB x4, BGA BiCS4, QDP	1,180	0.7
1920GB	512GB x4, BGA BiCS4, ODP	2,490	0.7
240GB	128GB x2, BGA BiCS5, DDP	285	0.7
480GB	128GB x4, BGA BiCS5, DDP	635	0.8
960GB	256GB x4, BGA BiCS5, QDP	1,400	0.8
1920GB	512GB x4, BGA BiCS5, ODP	2,800	0.8

**Notes:**

1. TBW is measured by JEDEC Client 219A workload and calculated with PE count = 3000.
2. TBW may differ according to flash configuration and platform.
3. DWPD is calculated based on 5-year lifetime.
4. The SSD supports trim function. If Operation System does not support trim command, performance and TBW will be affected. (Like certain Windows OS, Linux kernel version before 2.6.33, other OS please reference each own user manual)
5. The endurance of SSD could be estimated based on user behavior, NAND endurance cycles, and write amplification factor.

### 3.3. UBER (Uncorrectable Bit Error Rates)

Capacity	UBER
240GB	< 1 sector per 10 <sup>16</sup> bits read
480GB	
960GB	
1920GB	

**Notes:**

1. UBER (Uncorrectable Bit Error Rates) means the uncorrectable error per bits read.
2. UBER = FER (fail rate) / Data Size (user data bit).
3. FER = uncorrectable ECC frame number / total ECC frame number.
4. The LDPC for TLC ECC capability > 120bit/KB.

### 3.4. MTBF

MTBF, Mean Time between Failures, is a measure of reliability of a device. Its value represents the average time between a repair and the next failure. The unit of MTBF is in hours. The higher the MTBF value, the higher the reliability of the device.

Our MTBF result is based on simulation software (Relex 7.3). Please note that a lower MTBF should be expected for higher capacity drives, and we apply the lowest MTBF for all capacities.

Capacity	MTBF
240GB	2 million hours
480GB	
960GB	
1920GB	

## 4. ELECTRICAL SPECIFICATIONS



### 4.1. Supply Voltage

Parameter	Rating
Operating Voltage	3.3V ± 5%
Rise Time (Max/Min)	100ms / 0.1ms
Fall Time (Max/Min)	5s / 1ms
Min. off Time <sup>Note1</sup>	1s

**Notes:**

1. Minimum time between power removed from SSD (Vcc < 100 mV) and power re-applied to the drive.
2. Ensure the voltage of each power domain in SSD has enough time to discharge less than 0.1V.
3. Rise Time during from 10% to 90% of 3.3V.
4. Fall Time during from 90% to 10% of 3.3V.

### 4.2. Power Consumption

Capacity	Flash Type	Read	Write	Idle
240GB	64GB x4, BGA BiCS3, DDP	3,900	2,700	2,000
480GB	128GB x4, BGA BiCS3, QDP	4,100	3,400	2,000
960GB	256GB x4, BGA BiCS3, ODP	5,000	5,300	2,000
1920GB	512GB x4, BGA BiCS3, ODP	5,200	5,000	2,000
240GB	64GB x4, BGA BiCS4, DDP	4,500	3,500	2,000
480GB	128GB x4, BGA BiCS4, QDP	4,800	4,500	2,000
960GB	256GB x4, BGA BiCS4, QDP	5,000	5,000	2,000
1920GB	512GB x4, BGA BiCS4, ODP	5,200	5,800	2,000
240GB	128GB x2, BGA BiCS5, DDP	4,000	3,300	2,000
480GB	128GB x4, BGA BiCS5, DDP	5,000	4,800	2,000
960GB	256GB x4, BGA BiCS5, QDP	5,200	5,800	2,000
1920GB	512GB x4, BGA BiCS5, ODP	5,500	6,000	2,000

Unit: mW

**Notes:**

1. Use CrystalDiskMark 6.0 with the setting of 1000MB. Sequentially read and write the disk for 5 times, and measure power consumption during sequential Read [1/5]~[5/5] or sequential Write [1/5]~[5/5].
2. Power Consumption may differ according to flash configuration and platform.
3. Measurement environment: Room temperature: 20~25°C, humidity: 40~60%RH, DC +3.3V condition.



## 5. INTERFACE



### 5.1. Pin Assignment and Descriptions

The follow table defines the signal assignment of the internal NGFF connector for SSD usage, described in the PCI Express M.2 Specification version 1.1 of the PCI-SIG.



Pin #	SATA Pin	Description
1	GND	Ground
2	3.3V	3.3V source
3	GND	Ground
4	3.3V	3.3V source
5	PETn3	PCIe TX Differential signal defined by the PCI Express M.2 spec
6	N/C	No connect
7	PETp3	PCIe TX Differential signal defined by the PCI Express M.2 spec
8	N/C	No connect
9	GND	Ground
10	LED1#	Open drain, active low signal. These signals are used to allow the add-in card to provide status indicators via LED devices that will be provided by the system.
11	PERn3	PCIe RX Differential signal defined by the PCI Express M.2 spec
12	3.3V	3.3V source
13	PERp3	PCIe RX Differential signal defined by the PCI Express M.2 spec
14	3.3V	3.3V source
15	GND	Ground
16	3.3V	3.3V source
17	PETn2	PCIe RX Differential signal defined by the PCI Express M.2 spec
18	3.3V	3.3V source
19	PETp2	PCIe RX Differential signal defined by the PCI Express M.2 spec
20	N/C	No connect
21	GND	Ground
22	N/C	No connect
23	PERn2	PCIe RX Differential signal defined by the PCI Express M.2 spec

**UD info CORP. TEL: +886-2-7713-6050 FAX: +886-2-8511-3151**

**3F-4, No.8, Ln. 609, Sec. 5, Chongxin Rd., Sanchong Dist., New Taipei City 241, Taiwan (R.O.C.)**

Pin #	SATA Pin	Description
24	N/C	No connect
25	PERp2	PCIe RX Differential signal defined by the PCI Express M.2 spec
26	N/C	No connect
27	GND	Ground
28	N/C	No connect
29	PETn1	PCIe TX Differential signal defined by the PCI Express M.2 spec
30	N/C	No connect
31	PETp1	PCIe TX Differential signal defined by the PCI Express M.2 spec
32	N/C	No connect
33	GND	Ground
34	N/C	No connect
35	PERn1	PCIe RX Differential signal defined by the PCI Express M.2 spec
36	N/C	No connect
37	PERp1	PCIe RX Differential signal defined by the PCI Express M.2 spec
38	N/C	No connect
39	GND	Ground
40	SMB_CLK (I/O)(0/1.8V)	SMBus Clock; Open Drain with pull-up on platform.
41	PETn0	PCIe TX Differential signal defined by the PCI Express M.2 spec
42	SMB_DATA (I/O)(0/1.8V)	SMBus Data; Open Drain with pull-up on platform.
43	PETp0	PCIe TX Differential signal defined by the PCI Express M.2 spec
44	ALERT#(O)(0/1.8V)	-
45	GND	Ground
46	N/C	No connect
47	PERn0	PCIe RX Differential signal defined by the PCI Express M.2 spec
48	N/C	No connect
49	PERp0	PCIe RX Differential signal defined by the PCI Express M.2 spec
50	PERST#(I)(0/3.3V)	PE-Reset is a functional reset to the card as defined by the PCIe Mini CEM specification.
51	GND	Ground
52	CLKREQ#(I/O)(0/3.3V)	Clock Request is a reference clock request signal as defined by the PCIe Mini CEM specification; Also used by L1 PM Sub-states.
53	REFCLKn	PCIe Reference Clock signals (100 MHz) defined by the PCI Express M.2 spec.
54	PEWAKE#(I/O)(0/3.3V)	-
55	REFCLKp	PCIe Reference Clock signals (100 MHz) defined by the PCI Express M.2 spec.

**UD info CORP. TEL: +886-2-7713-6050 FAX: +886-2-8511-3151**

3F-4, No.8, Ln. 609, Sec. 5, Chongxin Rd., Sanchong Dist., New Taipei City 241, Taiwan (R.O.C.)

Pin #	SATA Pin	Description
56	Reserved for MFG DATA	Manufacturing Data line. Used for SSD manufacturing only. Not used in normal operation. Pins should be left N/C in platform Socket.
57	GND	Ground
58	Reserved for MFG CLOCK	Manufacturing Clock line. Used for SSD manufacturing only. Not used in normal operation. Pins should be left N/C in platform Socket.
59	Module Key M	Module Key
60	Module Key M	
61	Module Key M	
62	Module Key M	
63	Module Key M	
64	Module Key M	
65	Module Key M	
66	Module Key M	
67	N/C	No Connect
68	SUSCLK(32KHz) (I)(0/3.3V)	-
69	N/C	PEDET (NC-PCIe). No Connect for PCIe.
70	3.3V	3.3V source
71	GND	Ground
72	3.3V	3.3V source
73	GND	Ground
74	3.3V	3.3V source
75	GND	Ground

## 6. SUPPORTED COMMANDS



### 6.1. NVMe Command List

**Table 6-1 Admin Commands**

Op-Code	O/M	Command Description
00h	M	Delete I/O Submission Queue
01h	M	Create I/O Submission Queue
02h	M	Get Log Page
04h	M	Delete I/O Completion Queue
05h	M	Create I/O Completion Queue
06h	M	Identify
08h	M	Abort
09h	M	Set Features
0Ah	M	Get Features
0Ch	M	Asynchronous Event Request
10h	O	Firmware Activate
11h	O	Firmware Image Download
14h	O	Device Self-test
80h	O	Format NVM
81h	O	Security Send
82h	O	Security Receive
84h	O	Sanitize

**Table 6-2 I/O Commands**

Op-Code	O/M	Command Description
00h	O	Flush
01h	O	Write
02h	O	Read
04h	O	Write Uncorrectable
05h	O	Compare
08h	O	Write Zeroes
09h	O	Dataset Management

**Table 6-3 Set Feature Commands**

Op-Code	O/M	Command Description
00h		Reserved
01h	M	Arbitration
02h	M	Power Management
03h	O	LBA Range Type
04h	M	Temperature Threshold
05h	M	Error Recovery
06h	O	Volatile Write Cache
07h	M	Number of Queues
08h	M	Interrupt Coalescing
09h	M	Interrupt Vector Configuration
0Ah	M	Write Atomicity Normal
0Bh	M	Asynchronous Event Configuration
0Ch	O	Autonomous Power State Transition
0Dh	O	Host Memory Buffer
0Eh	O	Timestamp
10h	O	Host Controlled Thermal Management
11h	O	Non-Operational Power State Config
0Eh – 7Dh		Reserved
80h	O	Software Progress Marker

**Table 6-4 Get Log Page Commands**

Op-Code	O/M	Command Description
00h		Reserved
01h	M	Error Information
02h	M	SMART / Health Information
03h	M	Firmware Slot Information
04h	O	Changed Namespace List
06h	O	Device Self-test
09h – 7Fh		Reserved
81h	O	Sanitize Status
82h - FFh		Reserved

## 6.2. Identify Device Data

The following table details the sector data returned by the IDENTIFY DEVICE command.

### ■ Identify Controller Data Structure

Bytes	O/M	Default Value	Description
01:00	M	0x1987	PCI Vendor ID (VID)
03:02	M	0x1987	PCI Subsystem Vendor ID (SSVID)
23:04	M	TBD	Serial Number (SN)
63:24	M	TBD	Model Number (MN)
71:64	M	TBD	Firmware Revision (FR)
72	M	0x01	Recommended Arbitration Burst (RAB)
75:73	M	0x6479A7	IEEE OUI Identifier (IEEE)
76	O	0x00	Controller Multi-Path I/O and Namespace Sharing Capabilities (CMIC)
77	M	0x09	Maximum Data Transfer Size (MDTS)
79:78	M	0x0001	Controller ID (CNTLID)
83:80	M	0x00010300	Version (VER)
87:84	M	0x00989680(10sec)	RTD3 Resume Latency (RTD3R)
91:88	M	0x00989680(10sec)	RTD3 Entry Latency (RTD3E)
95:92	M	0x00000200	Optional Asynchronous Events Supported (OAES)
99:96	M	0x0002	Controller Attributes (CTRATT)
111:100	O	0x00	Reserved
127:112	O	0x00	FRU Globally Unique Identifier (FGUID)
239:128	-	0x00	Reserved
255:240	-	0x00	Refer to the NVMe Management Interface Specification for definition
257:256	M	0x0017	Optional Admin Command Support (OACS)
258	M	0x03	Abort Command Limit (ACL)
259	M	0x03	Asynchronous Event Request Limit (AERL)
260	M	0x12	Firmware Updates (FRMW)
261	M	0x08	Log Page Attributes (LPA)
262	M	0x3E	Error Log Page Entries (ELPE)
263	M	0x00	Number of Power States Support (NPSS)
264	M	0x01	Admin Vendor Specific Command Configuration (AVSCC)
265	O	0x00	Autonomous Power State Transition Attributes (APSTA)
267:266	M	0x016B	Warning Composite Temperature Threshold (WCTEMP)
269:268	M	0x0170	Critical Composite Temperature Threshold (CCTEMP)
271:270	O	0x64 10sec	Maximum Time for Firmware Activation (MTFA)

**UD info CORP. TEL: +886-2-7713-6050 FAX: +886-2-8511-3151**

**3F-4, No.8, Ln. 609, Sec. 5, Chongxin Rd., Sanchong Dist., New Taipei City 241, Taiwan (R.O.C.)**

Bytes	O/M	Default Value	Description
275:272	O	0x00000000	Host Memory Buffer Preferred Size (HMPRE)
279:276	O	0x00000000	Host Memory Buffer Minimum Size (HMMIN)
295:280	O	**	Total NVM Capacity (TNVMCAP)
311:296	O	**	Unallocated NVM Capacity (UNVMCAP)
315:312	O	0x00000000	Replay Protected Memory Block Support (RPMBS)
317:316	O	0x0A	Extended Device Self-test Time (EDSTT)
318	O	0x00	Device Self-test Options (DSTO)
319	M	0x01	Firmware Update Granularity (FWUG)
321:320	M	0x0000	Keep Alive Support (KAS)
323:322	O	0x01	Host Controlled Thermal Management Attributes (HCTMA)
325:324	O	0x0139	Minimum Thermal Management Temperature (MNTMT)
327:326	O	0x0166	Maximum Thermal Management Temperature (MXTMT)
331:328	O	0x00000000	Sanitize Capabilities (SANICAP)
511:332	-	0x00	Reserved
<b>NVM Command Set Attributes</b>			
512	M	0x66	Submission Queue Entry Size (SQES)
513	M	0x44	Completion Queue Entry Size (CQES)
515:514	M	0x0100	Maximum Outstanding Commands (MAXCMD)
519:516	M	0x00000001	Number of Namespaces (NN)
521:520	M	0x005D	Optional NVM Command Support (ONCS)
523:522	M	0x0000	Fused Operation Support (FUSES)
524	M	0x00	Format NVM Attributes (FNA)
525	M	0x01	Volatile Write Cache (VWC)
527:526	M	TBD	Atomic Write Unit Normal (AWUN)
529:528	M	TBD	Atomic Write Unit Power Fail (AWUPF)
530	M	0x01	NVM Vendor Specific Command Configuration (NVSCC)
531	-	0x00	Reserved
533:532	O	0x0000	Atomic Compare & Write Unit (ACWU)
535:534	-	0x0000	Reserved
539:536	O	0x00000000	SGL Support (SGLS)
767:540	-	0x00	Reserved
<b>IO Command Set Attributes</b>			
1023:768	M	0x00	NVM Subsystem NVMe Qualified Name (SUBNQN)
1791:1024	-	0x00	Reserved
2047:1792	-	0x00	Reserved

Bytes	O/M	Default Value	Description
2079:2048	M	TBD	Power State 0 Descriptor (PSD0)
2111:2080	O	0x00	Power State 1 Descriptor (PSD1)
2143:2112	O	0x00	Power State 2 Descriptor (PSD2)
2175:2144	O	0x00	Power State 3 Descriptor (PSD3)
2207:2176	O	0x00	Power State 4 Descriptor (PSD4)
2239:2208	O	0x00	Power State 5 Descriptor (PSD5)
2271:2240	O	0x00	Power State 6 Descriptor (PSD6)
2303:2272	O	0x00	Power State 7 Descriptor (PSD7)
2335:2304	O	0x00	Power State 8 Descriptor (PSD8)
2367:2336	O	0x00	Power State 9 Descriptor (PSD9)
2399:2368	O	0x00	Power State 10 Descriptor (PSD10)
2431:2400	O	0x00	Power State 11 Descriptor (PSD11)
2463:2432	O	0x00	Power State 12 Descriptor (PSD12)
2495:2464	O	0x00	Power State 13 Descriptor (PSD13)
2527:2496	O	0x00	Power State 14 Descriptor (PSD14)
2559:2528	O	0x00	Power State 15 Descriptor (PSD15)
2591:2560	O	0x00	Power State 16 Descriptor (PSD16)
2623:2592	O	0x00	Power State 17 Descriptor (PSD17)
2655:2624	O	0x00	Power State 18 Descriptor (PSD18)
2687:2656	O	0x00	Power State 19 Descriptor (PSD19)
2719:2688	O	0x00	Power State 20 Descriptor (PSD20)
2751:2720	O	0x00	Power State 21 Descriptor (PSD21)
2783:2752	O	0x00	Power State 22 Descriptor (PSD22)
2815:2784	O	0x00	Power State 23 Descriptor (PSD23)
2847:2816	O	0x00	Power State 24 Descriptor (PSD24)
2879:2848	O	0x00	Power State 25 Descriptor (PSD25)
2911:2880	O	0x00	Power State 26 Descriptor (PSD26)
2943:2912	O	0x00	Power State 27 Descriptor (PSD27)
2975:2944	O	0x00	Power State 28 Descriptor (PSD28)
3007:2976	O	0x00	Power State 29 Descriptor (PSD29)
3039:3008	O	0x00	Power State 30 Descriptor (PSD30)
3071:3040	O	0x00	Power State 31 Descriptor (PSD31)
<b>Vendor Specific</b>			
3278:3072	O	0x00	Vendor Specific (VS)
3279	O	0x00	Vendor Specific (VS)



4095:3280	0	Vendor Reserved	Vendor Specific (VS)
-----------	---	-----------------	----------------------

\* The OUI shall be a valid IEEE/RAC assigned identifier that may be registered at

<http://standards.ieee.org/develop/regauth/oui/public.html>.

\*\* Depends on the using of capacity



## ■ Identify Namespace Data Structure & NVM Command Set Specific

Bytes	O/M	Default Value	Description
7:0	M	TBD*	Namespace Size (NSZE)
15:8	M	TBD*	Namespace Capacity (NCAP)
23:16	M	TBD*	Namespace Utilization (NUSE)
24	M	0x00	Namespace Features (NSFEAT)
25	M	0x01	Number of LBA Formats (NLBAF)
26	M	0x00	Formatted LBA Size (FLBAS)
27	M	0x00	Metadata Capabilities (MC)
28	M	0x00	End-to-end Data Protection Capabilities (DPC)
29	M	0x00	End-to-end Data Protection Type Settings (DPS)
30	O	0x00	Namespace Multi-path I/O and Namespace Sharing Capabilities (NMIC)
31	O	0x00	Reservation Capabilities (RESCAP)
32	O	0x00	Format Progress Indicator (FPI)
33	-	0x09	Reserved
35:34	O	0x0000	Namespace Atomic Write Unit Normal (NAWUN)
37:36	O	0x0000	Namespace Atomic Write Unit Power Fail (NAWUPF)
39:38	O	0x0000	Namespace Atomic Compare & Write Unit (NACWU)
41:40	O	0x0000	Namespace Atomic Boundary Size Normal (NABSN)
43:42	O	0x0000	Namespace Atomic Boundary Offset (NABO)
45:44	O	0x0000	Namespace Atomic Boundary Size Power Fail (NABSPF)
47:46	-	0x0000	Reserved
63:48	O	0x00	NVM Capacity (NVMCAP)
103:64	-	0x00	Reserved
119:104	O	0x00	Namespace Globally Unique Identifier (NGUID)
127:120	O	0x373900F0FFA779 64	IEEE Extended Unique Identifier (EUI64)
131:128	M	0x02090000	LBA Format 0 Support (LBAF0)
135:132	O	0x00000000	LBA Format 1 Support (LBAF1)
139:136	O	0x00000000	LBA Format 2 Support (LBAF2)
143:140	O	0x00000000	LBA Format 3 Support (LBAF3)
147:144	O	0x00000000	LBA Format 4 Support (LBAF4)
151:148	O	0x00000000	LBA Format 5 Support (LBAF5)
155:152	O	0x00000000	LBA Format 6 Support (LBAF6)
159:156	O	0x00000000	LBA Format 7 Support (LBAF7)
163:160	O	0x00000000	LBA Format 8 Support (LBAF8)

**UD info CORP. TEL: +886-2-7713-6050 FAX: +886-2-8511-3151**

**3F-4, No.8, Ln. 609, Sec. 5, Chongxin Rd., Sanchong Dist., New Taipei City 241, Taiwan (R.O.C.)**

Bytes	O/M	Default Value	Description
167:164	O	0x00000000	LBA Format 9 Support (LBAF9)
171:168	O	0x00000000	LBA Format 10 Support (LBAF10)
175:172	O	0x00000000	LBA Format 11 Support (LBAF11)
179:176	O	0x00000000	LBA Format 12 Support (LBAF12)
183:180	O	0x00000000	LBA Format 13 Support (LBAF13)
187:184	O	0x00000000	LBA Format 14 Support (LBAF14)
191:188	O	0x00000000	LBA Format 15 Support (LBAF15)
383:192	-	0x00	Reserved

\* See IDEMA SPEC

\*\* See IEEE EUI-64 SPEC

### ■ List of Identify Namespace Data Structure for Each Capacity

Capacity (GB)	Byte[7:0]: Namespace Size (NSZE)
240	1BF244B0h
480	37E436B0h
960	6FC81AB0h
1920	DF8FE2B0h

### 6.3. SMART Attributes

■ SMART Attributes (Log Identifier 02h)

Bytes Index	Bytes	Description
[0]	1	Critical Warning
[2:1]	2	Composite Temperature
[3]	1	Available Spare
[4]	1	Available Spare Threshold
[5]	1	Percentage Used
[31:6]	26	Reserved
[47:32]	16	Data Units Read
[63:48]	16	Data Units Written
[79:64]	16	Host Read Commands
[95:80]	16	Host Write Commands
[111:96]	16	Controller Busy Time
[127:112]	16	Power Cycles
[143:128]	16	Power On Hours
[159:144]	16	Unsafe Shutdowns
[175:160]	16	Media and Data Integrity Errors
[191:176]	16	Number of Error Information Log Entries
[195:192]	4	Warning Composite Temperature Time
[199:196]	4	Critical Composite Temperature Time
[201:200]	2	Temperature Sensor 1 (Current Temperature)
[203:202]	2	Temperature Sensor 2 (N/A)
[205:204]	2	Temperature Sensor 3 (N/A)
[207:206]	2	Temperature Sensor 4 (N/A)
[209:208]	2	Temperature Sensor 5 (N/A)
[211:210]	2	Temperature Sensor 6 (N/A)
[213:212]	2	Temperature Sensor 7 (N/A)
[215:214]	2	Temperature Sensor 8 (N/A)
[511:216]	296	Reserved

## 7. PHYSICAL DIMENSION



Type1: Dimension: 80mm(L) x 22mm(W) x 3.5mm(H) for Non-PLP PCBA

Type2: Dimension: 80mm(L) x 22mm(W) x 4.5mm(H) for PLP PCBA

### Side View

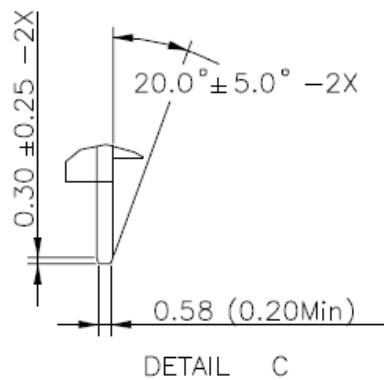
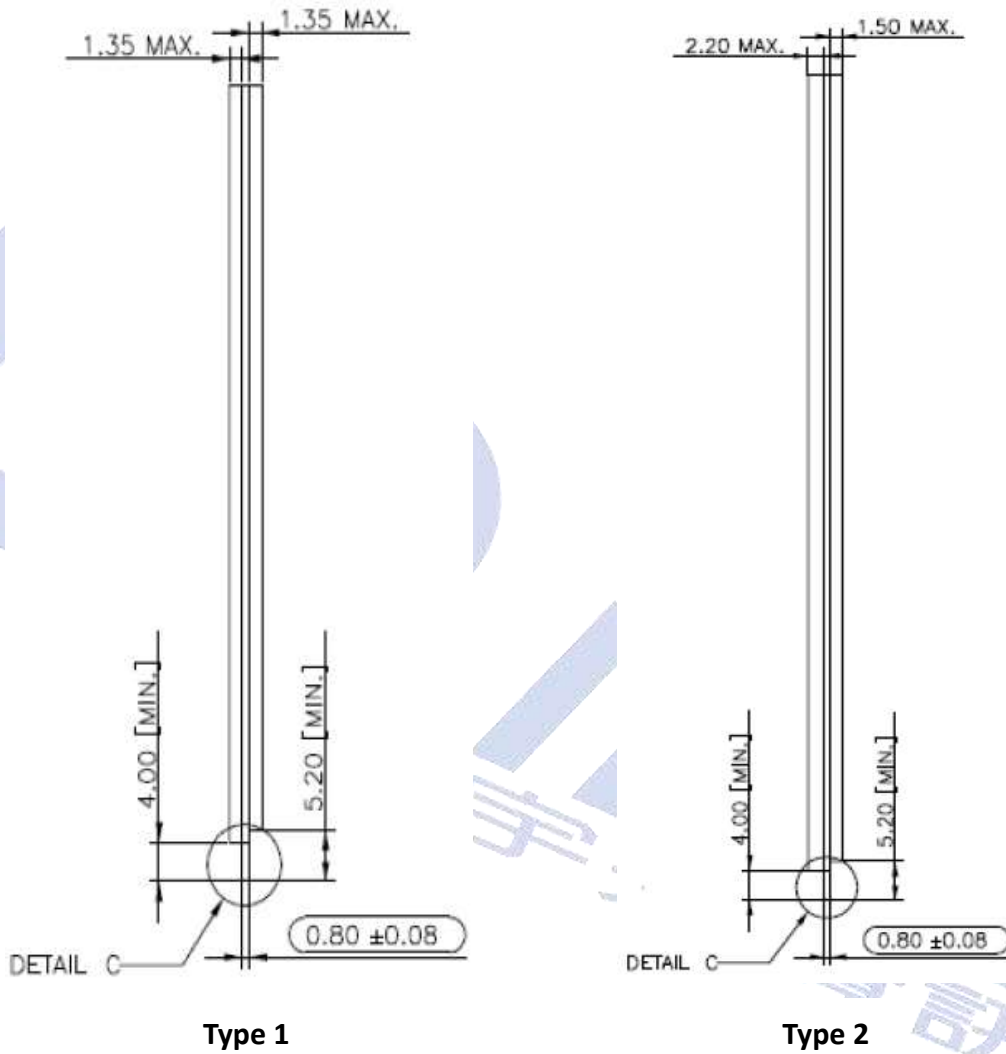

**Top View**

Unit : mm

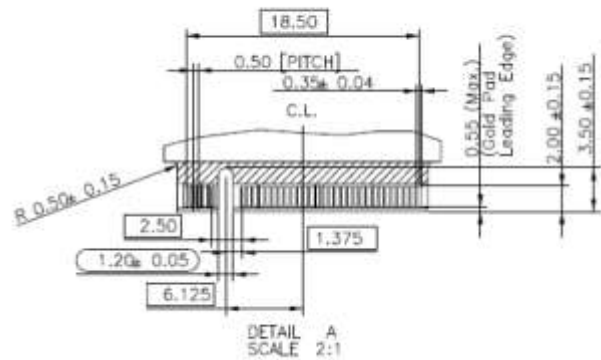
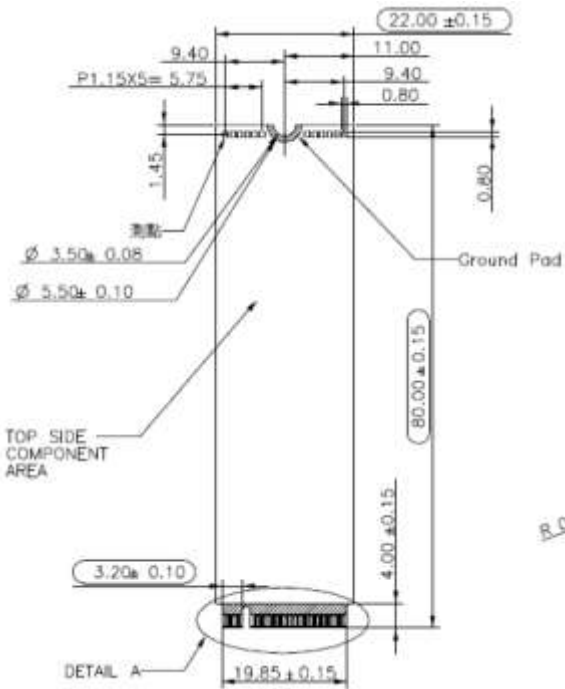

**Bottom View**

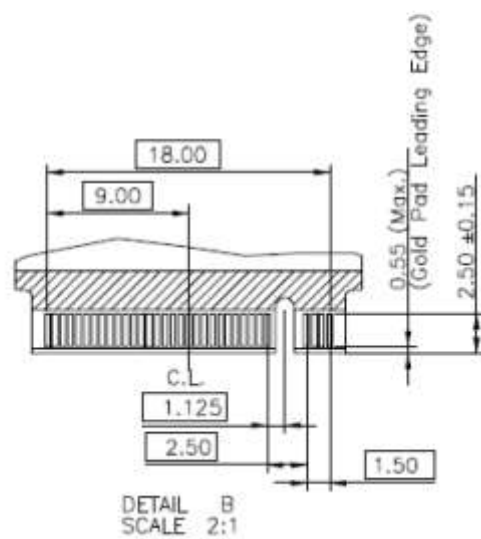
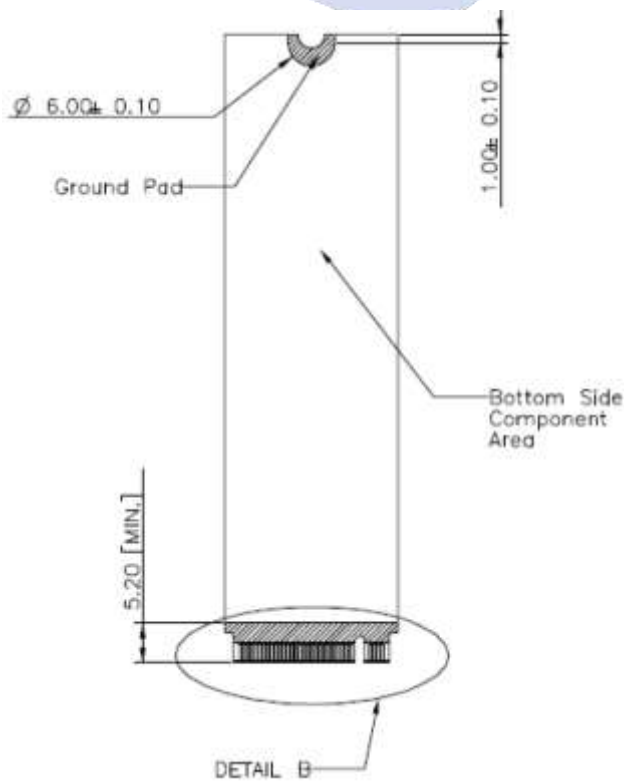

## 8. TERMINOLOGY



The following table is to list out the acronyms that have been applied throughout the document.

Term	Definitions
ATTO	Commercial performance benchmark application
DDR	Double data rate (SDRAM)
ASPM	Active States Power Management
APST	Autonomous Power State Transition
LBA	Logical block addressing
MTBF	Mean time between failures
PCIe	PCI Express / Peripheral Component Interconnect Express
S.M.A.R.T.	Self-monitoring, analysis and reporting technology

## 9. BARCODE DESCRIPTION

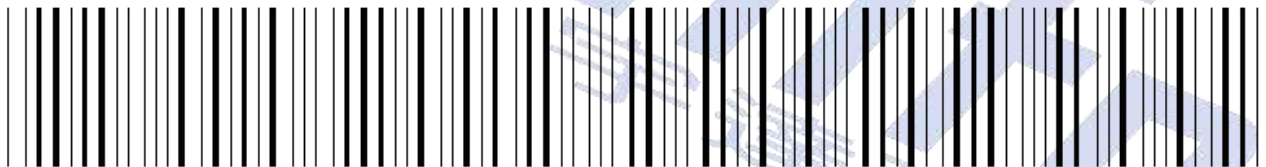

M 2 P 8 0 D C 9 6 0 G B A E P

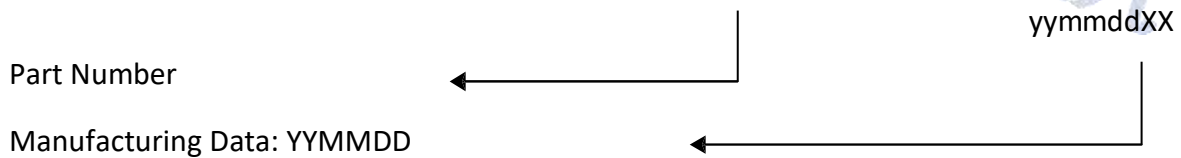

## 10. PARTNUMBER DECODER



M2P-80DCX<sup>8</sup>X<sup>9</sup>X<sup>10</sup>X<sup>11</sup>X<sup>12</sup>X<sup>13</sup>X<sup>14</sup>X<sup>15</sup>X<sup>16</sup>X<sup>17</sup>

X <sup>1</sup> X <sup>2</sup> X <sup>3</sup>	X <sup>4</sup> X <sup>5</sup>	X <sup>6</sup> X <sup>7</sup>	X <sup>8</sup> X <sup>9</sup> X <sup>10</sup> X <sup>11</sup> X <sup>12</sup>	X <sup>13</sup>	X <sup>14</sup>	X <sup>15</sup>	X <sup>16</sup> X <sup>17</sup>
M2P	80	DC	240GB 480GB 960GB 1920G	A: 3D TLC Standard (0°C ~ +70°C) B: 3D TLC Industrial (-40°C ~ +85°C)	E	P U	blank
<b>X<sup>14</sup></b> E: Gen3 x4							
<b>X<sup>15</sup></b> P: Non-PLP PCBA U: PLP PCBA							
<b>X<sup>16</sup>X<sup>17</sup></b> Blank: standard 06: Conformal Coating (CC) 31: AES+OPAL 32: AES+OPAL+PLP 43: AES+OPAL+CC							