

# EGL2290 SERIES SLIDE SWITCH

ANTI-VANDAL SWITCHES  
 DETECTOR SWITCHES  
 DIP SWITCHES  
 KEYLOCK SWITCHES  
 NAVIGATION SWITCHES  
 PUSHBUTTON SWITCHES  
 ROCKER SWITCHES  
 ROTARY SWITCHES  
 SLIDE SWITCHES  
 SNAP ACTION SWITCHES  
 TACTILE SWITCHES  
 TOGGLE SWITCHES  
 CAP OPTIONS

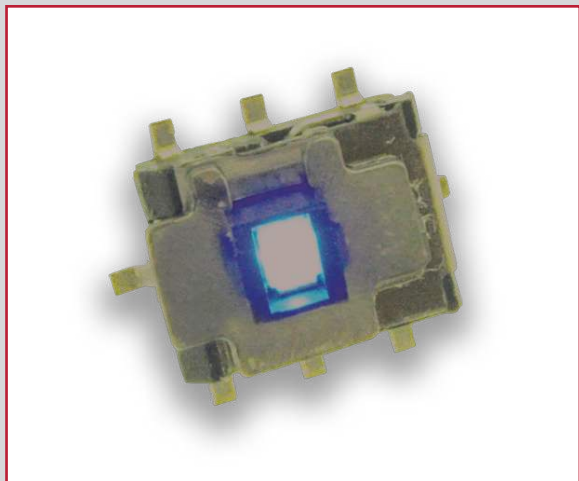

## APPLICATIONS / MARKETS

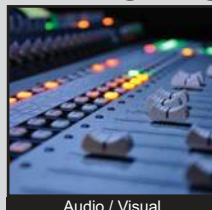

Audio / Visual

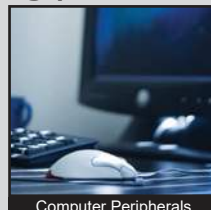

Computer Peripherals



Consumer Electronics



Instrumentation



Handheld Devices



Testing Equipment

**RoHS**

## SPECIFICATIONS

**Electrical Rating:** 0.3A, 6VDC  
**Electrical Life:** 10,000 Cycles  
**Contact Resistance:** 50mΩ  
**Insulation Resistance:** 100M Ω at 500VDC  
**Dielectric Strength:** 500VAC  
**Operating Temperature:** -40°C to 85°C  
**Storage Temperature:** -40°C to 85°C  
**Actuation Force:** 200 gf  
**Travel:** 2.0mm  
**Contact Arrangement:** DPDT

## FEATURES & BENEFITS

- LED illumination
- SMT design
- DPDT circuit
- Compact design

## PART NUMBER CONFIGURATOR

Series



EGL2290

LED Color



R = Red  
 G = Green  
 B = Blue  
 Y = Yellow  
 W = White  
 RG = Red-Green Bi-color

*Specifications subject to change without notice*



**E-SWITCH®**

www.e-switch.com

800.867.2717

2

# EGL2290 SERIES SLIDE SWITCH

## BODY DIMENSIONS

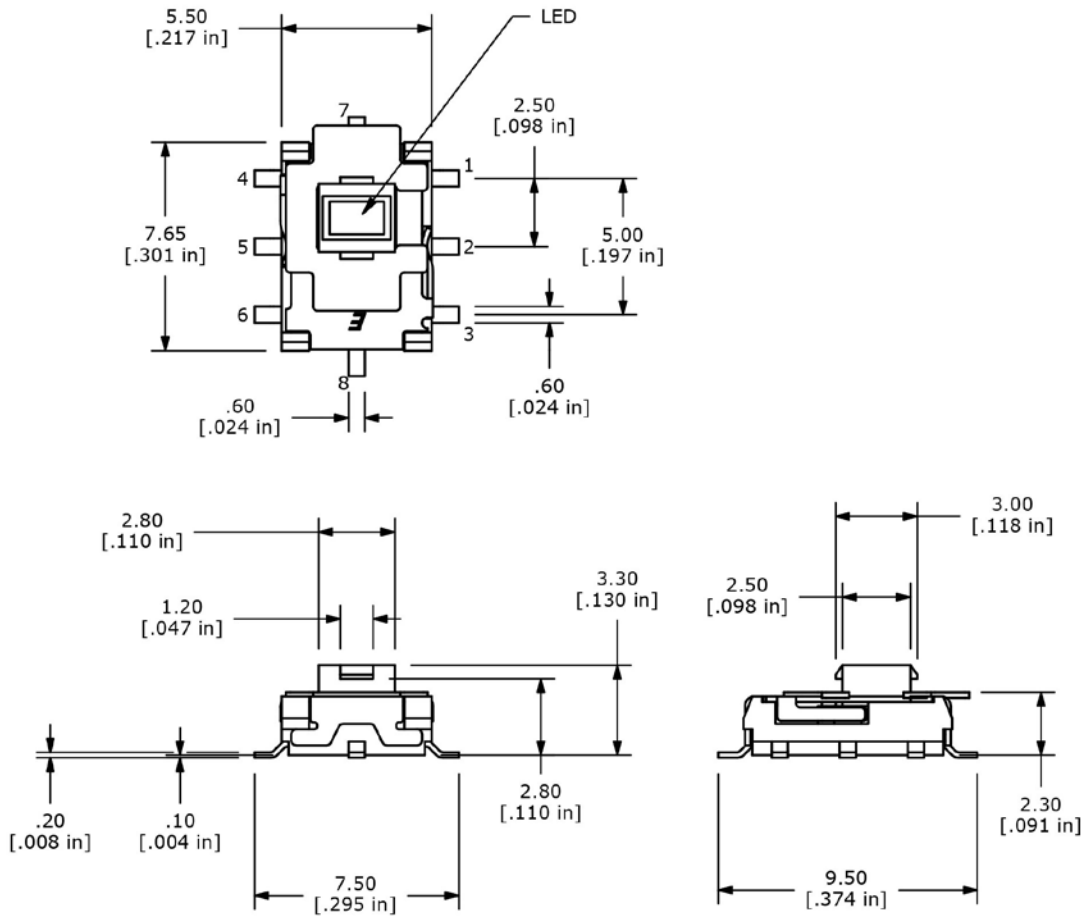

LED COLOR	LED SPECS		
LED COLOR	FORWARD CURRENT	FORWARD VOLTAGE @ 20mA	LUMINOUS INTENSITY @ 20mA
RED	20mA	1.95 typ.-2.5 max.	230 mcd typ.
GREEN	20mA	2.1 typ.- 2.5 max.	50 mcd typ.
BLUE	20mA	3.3 typ.- 4.0 max.	100 mcd typ.
YELLOW	20mA	2.0 typ.- 2.5 max.	150 mcd typ.
WHITE	20mA	3.3 typ.- 4.0 max.	200 mcd typ.
RED-GREEN	20mA	1.95 typ.-2.5 max. RED 2.1 typ.-2.5 max. GREEN	200 mcd typ. RED 50 mcd typ. GREEN

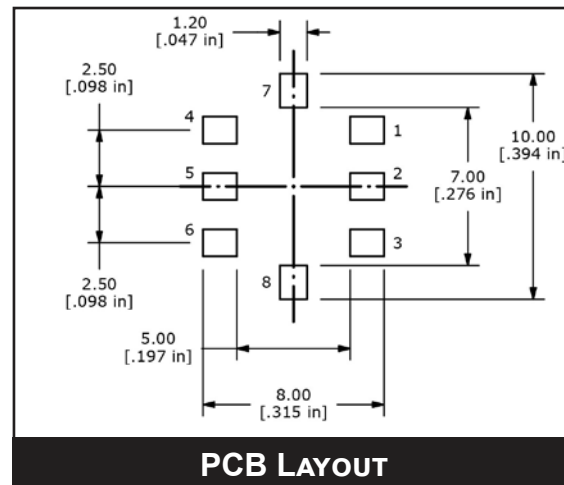
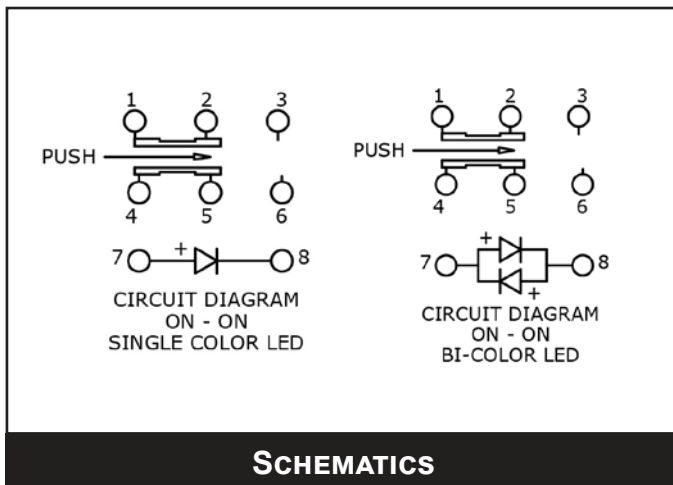

ANTI-VANDAL SWITCHES  
DETECTOR SWITCHES  
DIP SWITCHES  
KEYLOCK SWITCHES  
NAVIGATION SWITCHES  
PUSHBUTTON SWITCHES  
ROCKER SWITCHES  
ROTARY SWITCHES  
SLIDE SWITCHES  
SNAP ACTION SWITCHES  
TACTILE SWITCHES  
TOGGLE SWITCHES  
CAP OPTIONS