

PART NUMBER
SEE SHEET-2 TABLE

REVISION HISTORY					
REV	DOCUMENT	DESCRIPTION	CHGD BY	DATE	APPROVED
A	0112190	RELEASED	B.M.	2014-08-05	M. MIKE

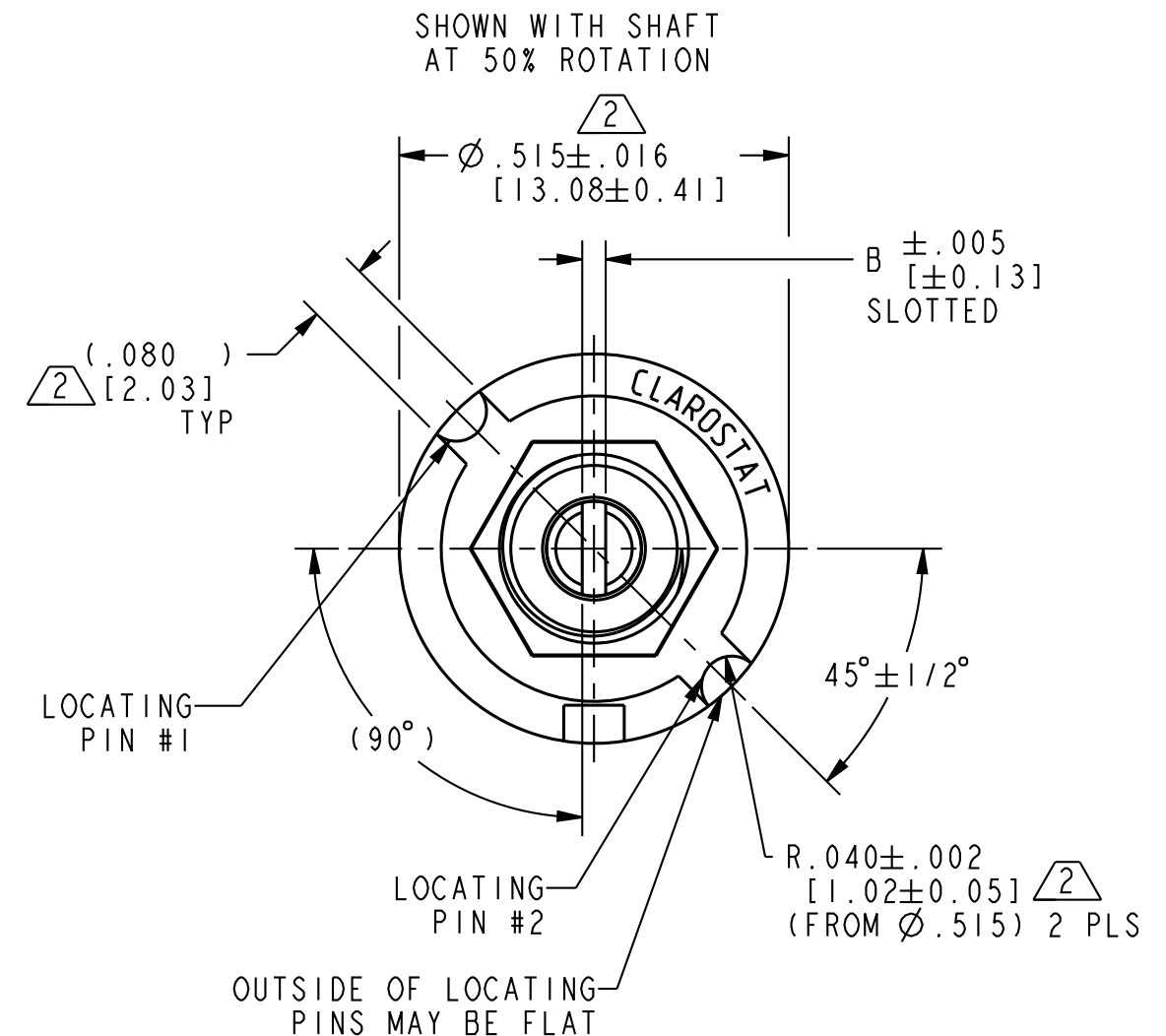
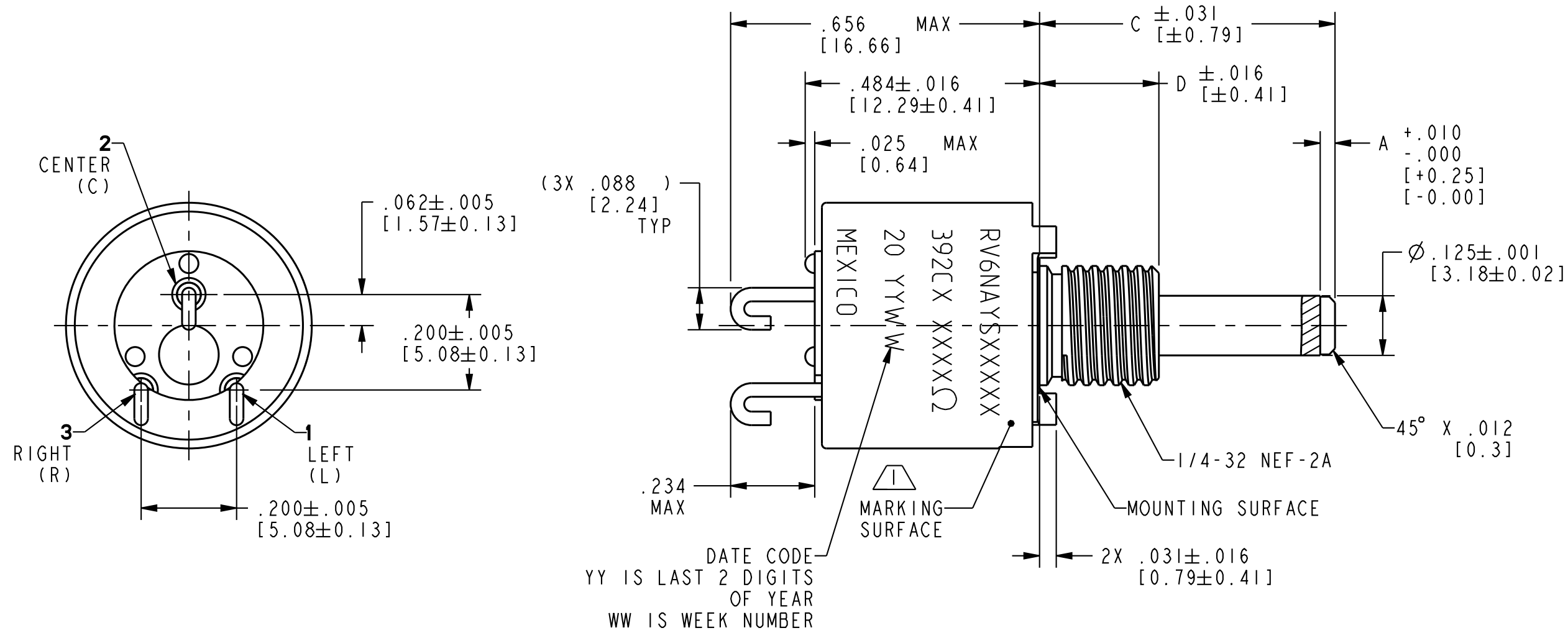

GENERAL SPECIFICATIONS AND NOTES:

- SERIES: 392
- CONDUCTIVE PLASTIC ELEMENT
- SUPPLIED WITH MOUNTING NUT AND LOCKING WASHER, PACKAGED ASSEMBLED OR UNASSEMBLED BASED ON LISTING (REFER TO TABLE ON SHEET2).
- MARKING INFORMATION SHOWN ON SIDE OF HOUSING. REFER TO TABLE FOR SPECIFIC LISTING MARKING INFORMATION.
- WEIGHT OF SINGLE CONTROL: .25 OUNCE [6.8 GRAMS] APPROX. VALUES ARE SHOWN IN STANDARD AND METRIC UNITS. METRIC UNITS ARE IN []. IF CONVERSION DIFFERENCE EXISTS, THE STANDARD UNIT PREVAILS.
- CONTROLS HAVE AN INTERNAL O-RING SHAFT SEAL.
- UNITS ARE SEALED FOR WAVE SOLDER AND WASH PROCESSING.
- BUILT IN ACCORDANCE WITH MIL-R-94.
- DIMENSIONS FOR BODY DIAMETER AND LOCATING PINS DEVIATE FROM MIL-R-94 SPECIFICATIONS.

ELECTRICAL SPECIFICATIONS:

- TAPER: LINEAR
- TAPER TOLERANCE ±20% OF NOMINAL RESISTANCE AT 50%±3% MECHANICAL ROTATION.
- LINEARITY (INDEPENDENT): ±5%
- MAX WORKING VOLTAGE: 350 VDC APPLIED ACROSS L & R TERMINALS. POWER NOT TO EXCEED RATING.
- DIELECTRIC STRENGTH: 750 VAC FOR 60s @ ATM [1 MPa]
- 350 VAC FOR 60s @ 3.4 IN Hg [11.5 KPa]
- POWER RATING: 0.5W @ 158°F [70°C], DE-RATED LINEARLY TO 0 @ 248°F [120°C]
- CRV FOR RESISTANCE GREATER THAN 500Ω AND LESS THAN 50KΩ IS 1.5% OF TOTAL RESISTANCE. CRV FOR ALL OTHER RESISTANCE VALUES IS 3.1% OF TOTAL RESISTANCE.
- END RESISTANCE: 4Ω MAX AT EACH END OF ROTATION
- RESISTANCE AND TOLERANCE: (REFER TO TABLE)
- ELECTRICAL ROTATION: 295°±5°
- EFFECTIVE ELECTRICAL ROTATION: 265° TYPICAL

OPERATIONAL SPECIFICATIONS:

- ROTATIONAL LIFE: 50,000 CYCLES
- STORAGE TEMPERATURE: -67°F [-55°C] TO 248°F [120°C]
- OPERATING TEMPERATURE: -40°F [-40°C] TO 248°F [120°C]
- ROTATIONAL TORQUE: 0.5 TO 2.0 OZ-IN [3.5 TO 14 mN·m]
- STOP TORQUE: 3 LB-IN [0.34 N·m] MIN
- MECHANICAL ROTATION: 295°±5°

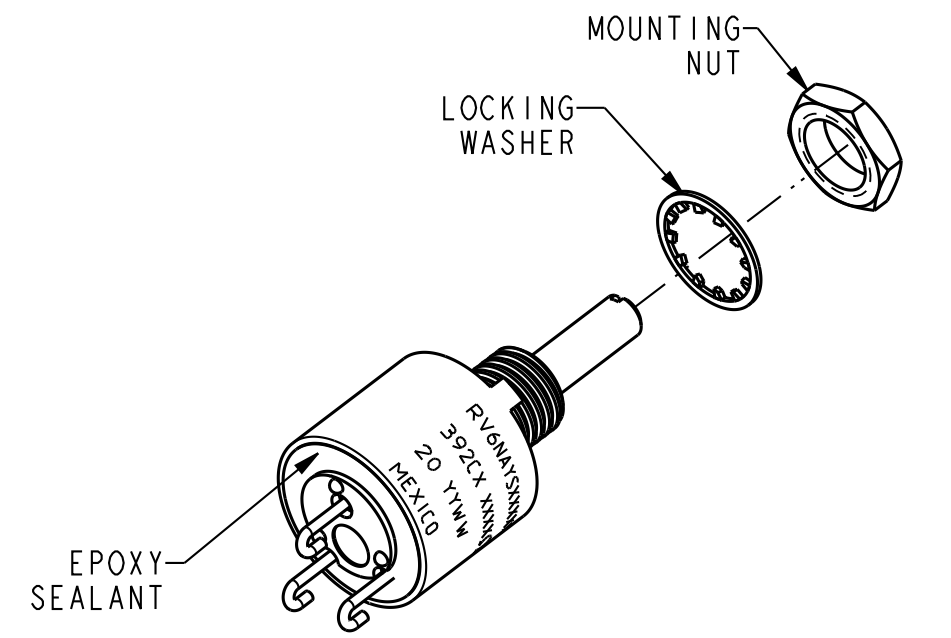
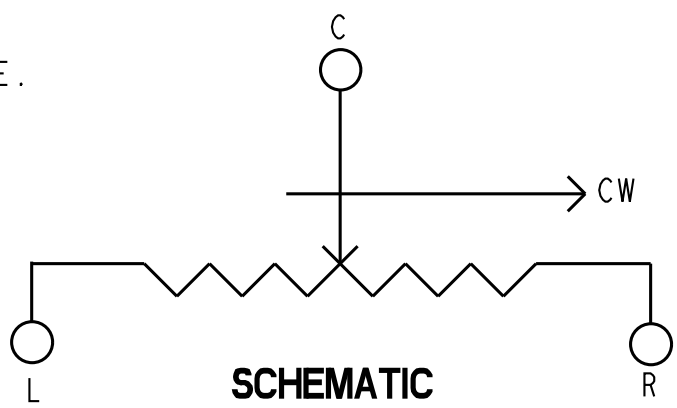
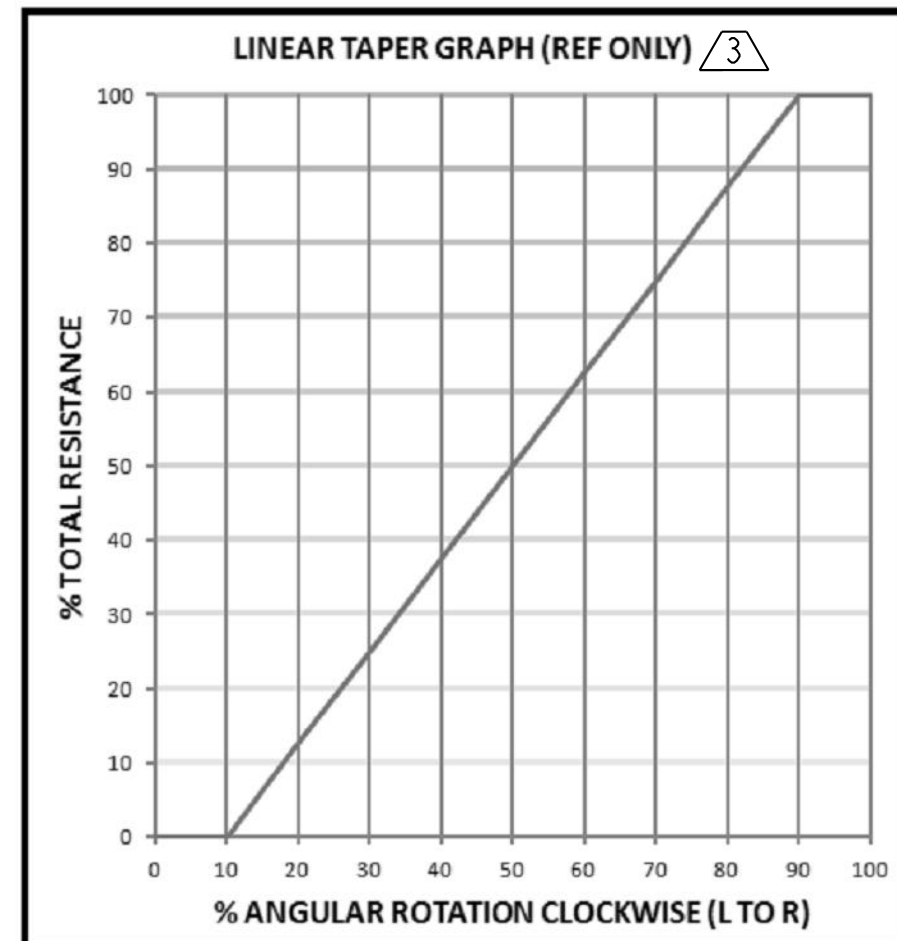

MATERIALS	
SHAFT	NICKEL PLATED BRASS
BUSHING	NICKEL PLATED BRASS
HOUSING	THERMOPLASTIC
BASE	THERMOSET
TERMINALS	BRASS, SOLDER (TIN-LEAD) DIP FINISH
SEALANT	EPOXY
LOCK WASHER	NICKEL PLATED PHOS BRONZE
MOUNTING NUT	NICKEL PLATED BRASS

UNLESS OTHERWISE SPECIFIED DIMENSIONS ARE IN INCHES DECIMAL TOL: NO PLACE --- ±.400 [10.16] 1 PLACE --- ±.030 [0.76] 2 PLACE --- ±.010 [0.25] 3 PLACE --- ±.005 [0.13] ANGULAR TOL --- ±2° CHAMFER --- ±5°		THIRD ANGLE PROJECTION		<h1>Honeywell</h1>	
MATERIAL SEE TABLE		FINISH			
TITLE S-TAPER, SLOTTED SHAFT, STD BUSHING, SOLDER HOOK TERMS		SIZE C	CAGE CODE -	DWG NO 392-MATRIX-IDWG-15	TYPE I
SCALE 4:1		REF WT: SEE NOTE	SHEET 1 of 2		
RELEASE DATE 2014-08-05		HONEYWELL CONFIDENTIAL <small>THIS DOCUMENT CONTAINS PROPRIETARY INFORMATION AND SUCH INFORMATION MAY NOT BE DISCLOSED TO OTHERS FOR ANY PURPOSE, NOR USED FOR MANUFACTURING PURPOSES WITHOUT WRITTEN PERMISSION FROM HONEYWELL</small>			
DRW: B. MOHAPATRA 2014-05-28		RDE: M. MIKE 2014-05-28			
QA: -		CHK: S. RAGHU 2014-08-05			
APPLICABLE DOCUMENTS: ASME Y14.100-2004 ASME Y14.5-2009		COMPUTER GENERATED DRAWING: PRO/ENGINEER			

**MULTI-SHEET
DRAWING**

4

3

2

PART NUMBER
SEE SHEET-2 TABLE

LISTING	CHARACTERISTICS							MARKING 			
	ELECTRICAL		MECHANICAL					LINE-1	LINE-2	LINE-3	LINE-4
	RES (Ω)	RES TOL	A SLOT DEPTH IN [mm]	B SLOT WIDTH IN [mm]	C SHAFT LENGTH IN [mm]	D BUSHING LENGTH IN [mm]	MTG HARDWARE				
392550M6965	10KΩ	±10%	.031 [0.79]	.031 [0.79]	.625 [15.88]	.250 [6.35]	UNASSEMBLED	RV6NAYSA103A	10KΩ	20 YYWW	MEXICO
392550M9277	5KΩ	±10%	.031 [0.79]	.031 [0.79]	.625 [15.88]	.250 [6.35]	UNASSEMBLED	RV6NAYSA502A	5KΩ	20 YYWW	MEXICO
392550M9392	50KΩ	±10%	.031 [0.79]	.031 [0.79]	.625 [15.88]	.250 [6.35]	UNASSEMBLED	RV6NAYSA503A	50KΩ	20 YYWW	MEXICO
392550M9510	100Ω	±10%	.031 [0.79]	.031 [0.79]	.500 [12.70]	.250 [6.35]	UNASSEMBLED	RV6NAYSB101A	100Ω	20 YYWW	MEXICO
392550M7183	10KΩ	±10%	.031 [0.79]	.031 [0.79]	.500 [12.70]	.250 [6.35]	UNASSEMBLED	RV6NAYSB103A	10KΩ	20 YYWW	MEXICO
392550M9618	5KΩ	±10%	.031 [0.79]	.031 [0.79]	.500 [12.70]	.250 [6.35]	UNASSEMBLED	RV6NAYSB502A	5KΩ	20 YYWW	MEXICO
392C3100	100Ω	±10%	.031 [0.79]	.031 [0.79]	.875 [22.23]	.250 [6.35]	ASSEMBLED	RV6NAYSD101A	392C3 100Ω	20 YYWW	MEXICO
392C31K	1KΩ	±10%	.031 [0.79]	.031 [0.79]	.875 [22.23]	.250 [6.35]	ASSEMBLED	RV6NAYSD102A	392C3 1KΩ	20 YYWW	MEXICO
392C310K	10KΩ	±10%	.031 [0.79]	.031 [0.79]	.875 [22.23]	.250 [6.35]	ASSEMBLED	RV6NAYSD103A	392C3 10KΩ	20 YYWW	MEXICO
392C3100K	100KΩ	±10%	.031 [0.79]	.031 [0.79]	.875 [22.23]	.250 [6.35]	ASSEMBLED	RV6NAYSD104A	392C3 100KΩ	20 YYWW	MEXICO
392C31MEG	1MEGΩ	±10%	.031 [0.79]	.031 [0.79]	.875 [22.23]	.250 [6.35]	ASSEMBLED	RV6NAYSD105A	392C3 1MEGΩ	20 YYWW	MEXICO
392C3250	250Ω	±10%	.031 [0.79]	.031 [0.79]	.875 [22.23]	.250 [6.35]	ASSEMBLED	RV6NAYSD251A	392C3 250Ω	20 YYWW	MEXICO
392C32500	2.5KΩ	±10%	.031 [0.79]	.031 [0.79]	.875 [22.23]	.250 [6.35]	ASSEMBLED	RV6NAYSD252A	392C3 2.5KΩ	20 YYWW	MEXICO
392C325K	25KΩ	±10%	.031 [0.79]	.031 [0.79]	.875 [22.23]	.250 [6.35]	ASSEMBLED	RV6NAYSD253A	392C3 25KΩ	20 YYWW	MEXICO
392C3250K	250KΩ	±10%	.031 [0.79]	.031 [0.79]	.875 [22.23]	.250 [6.35]	ASSEMBLED	RV6NAYSD254A	392C3 250KΩ	20 YYWW	MEXICO
392C3500	500Ω	±10%	.031 [0.79]	.031 [0.79]	.875 [22.23]	.250 [6.35]	ASSEMBLED	RV6NAYSD501A	392C3 500Ω	20 YYWW	MEXICO
392C35K	5KΩ	±10%	.031 [0.79]	.031 [0.79]	.875 [22.23]	.250 [6.35]	ASSEMBLED	RV6NAYSD502A	392C3 5KΩ	20 YYWW	MEXICO
392550M9627	5KΩ	±20%	.031 [0.79]	.031 [0.79]	.875 [22.23]	.250 [6.35]	UNASSEMBLED	RV6NAYSD502B	5KΩ	20 YYWW	MEXICO
392C350K	50KΩ	±10%	.031 [0.79]	.031 [0.79]	.875 [22.23]	.250 [6.35]	ASSEMBLED	RV6NAYSD503A	392C3 50KΩ	20 YYWW	MEXICO
392C3500K	500KΩ	±10%	.031 [0.79]	.031 [0.79]	.875 [22.23]	.250 [6.35]	ASSEMBLED	RV6NAYSD504A	392C3 500KΩ	20 YYWW	MEXICO
392C410K	10KΩ	±10%	.031 [0.79]	.031 [0.79]	.375 [9.53]	.250 [6.35]	ASSEMBLED	RV6NAYSL103A	392C4 10KΩ	20 YYWW	MEXICO
392C4100K	100KΩ	±10%	.031 [0.79]	.031 [0.79]	.375 [9.53]	.250 [6.35]	ASSEMBLED	RV6NAYSL104A	392C4 100KΩ	20 YYWW	MEXICO
392C4500K	500KΩ	±10%	.031 [0.79]	.031 [0.79]	.375 [9.53]	.250 [6.35]	ASSEMBLED	RV6NAYSL504A	392C4 500KΩ	20 YYWW	MEXICO
392C5100	100Ω	±10%	.031 [0.79]	.031 [0.79]	.875 [22.23]	.250 [6.35]	ASSEMBLED	RV6SAYSD101AP	392C5 100Ω	20 YYWW	MEXICO

Honeywell

TITLE					S-TAPER, SLOTTED SHAFT, STD BUSHING, SOLDER HOOK TERMS				
SIZE	CAGE CODE	DWG NO	TYPE	REV					
C	-	392-MATRIX-IDWG-15	I	A					
SCALE	NONE	REF WT: SEE NOTE	SHEET	2 of 2					

4

3

2