

THE INFORMATION CONTAINED HEREIN IS CONSIDERED "PROPRIETARY" TO BEL FUSE INC. AND SHALL NOT BE COPIED, REPRODUCED OR DISCLOSED WITHOUT THE WRITTEN APPROVAL OF BEL FUSE INC.

LED 1 POLARITY			LED 2 POLARITY		
PIN 17	PIN 18	COLOR	PIN 19	PIN 20	COLOR
-	+	YELLOW	+	-	ORANGE
			-	+	GREEN

RoHS



**ELECTRICAL CHARACTERISTICS @ 25°C**

**URNS RATIO**

TP1	1CT : 1CT ±2%
TP2	1CT : 1CT ±2%
TP3	1CT : 1CT ±2%
TP4	1CT : 1CT ±2%

**OCL @ 100kHz/100mVRMS (4CHANNEL)**

11mA DC BIAS 350µH MIN.

Compliant to IEEE 802.3at specification

**INS. LOSS**

0.1MHz TO 1MHz	-1.1 dB MAX
1MHz TO 65MHz	-0.8 dB MAX
65MHz TO 100MHz	-1.0 dB MAX
100MHz TO 125MHz	-1.2 dB MAX

**RET. LOSS (MIN)**

0.5MHz-40MHz	-18 dB
40MHz-100MHz	-12+20LOG(f/80MHz) dB

**CM TO CM REJ**

100kHz - 100MHz -30 dB MIN

**CM TO DM REJ**

100kHz - 100MHz -35 dB MIN

**HIPOT (Isolation Voltage):**

2250 VDC

100% OF PRODUCTION TESTED TO COMPLY

WITH IEEE 802.3 ISOLATION REQUIREMENTS

**BALANCED DC LINE CURRENT 720 mA MAX. @ 57 VDC CONTINUOUS**

1.2 A MAX. @ 57 VDC FOR 200 MILLISECONDS

**OPERATING TEMPERATURE:**

-40°C TO 85°C

**LED 1**

VF (FORWARD VOLTAGE) IF=20mA YELLOW 2.1V TYP.

λD (DOMINANT WAVELENGTH) IF=20mA YELLOW 590nm TYP.

**LED 2**

VF (FORWARD VOLTAGE) IF=20mA GREEN 2.2V TYP.

λD (DOMINANT WAVELENGTH) IF=20mA GREEN 570nm TYP.

ORANGE 2.0V TYP.

ORANGE 605nm TYP.

OPERATING TEMPERATURE: -40°C TO 85°C

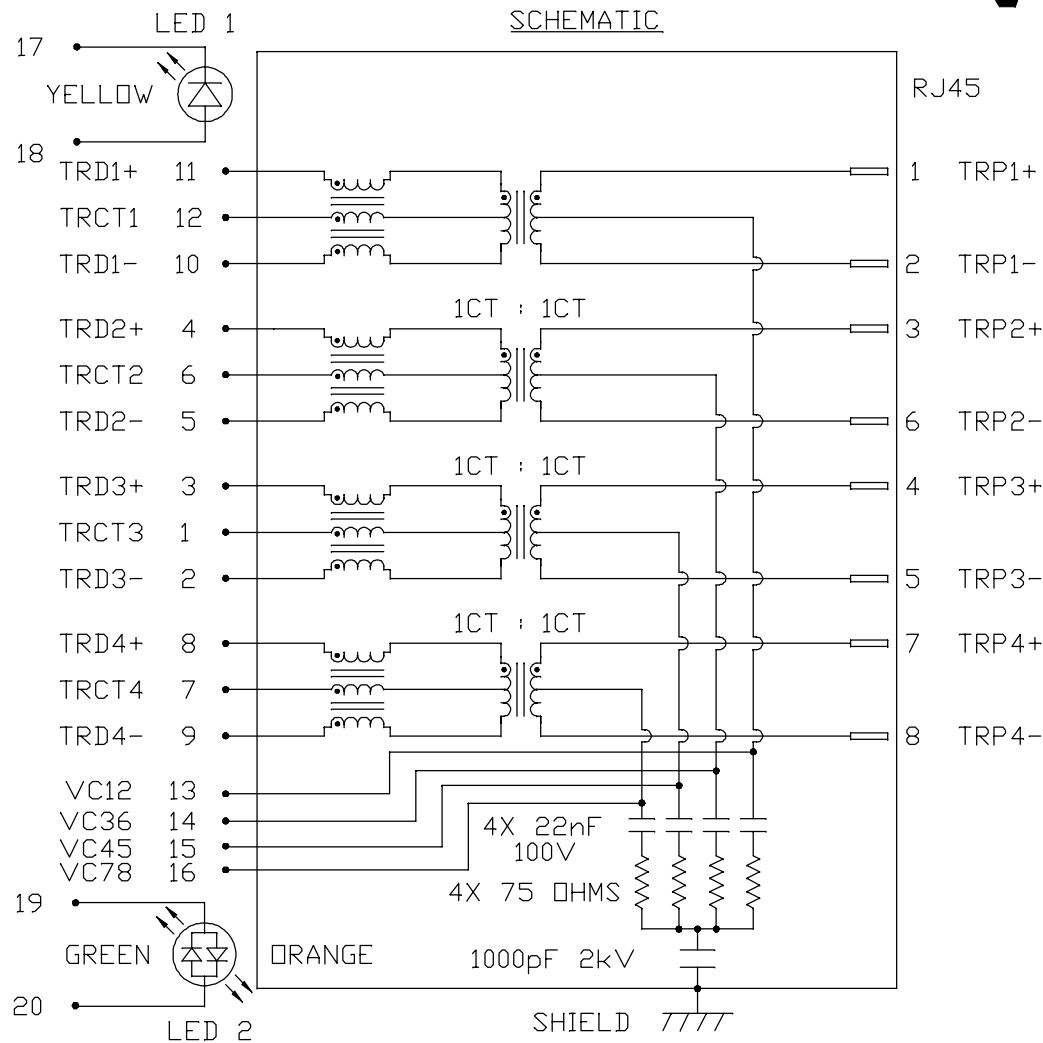

REV. : B PAGE : 2

<b>ORIGINATED BY</b> CHOW WANCHUNG	<b>TITLE</b> 1X4 glgabit MagJack® (PoEp, Extended Temperature)	<b>PART NO. / DRAWING NO.</b> 08261X4TGH-F	<b>STANDARD DIM.</b> TOL. IN INCH	[ ] METRIC DIM. AS REF.
<b>DATE</b> 2017-04-03				
<b>DRAWN BY</b> XIE YIMING	0826-1X4T-GH-F PATENTED	<b>FILE NAME</b> 08261X4TGH-F_B.DWG	.X	UNIT : INCH [mm]
<b>DATE</b> 2017-04-03			.XX	SCALE : N/A
			.XXX	SIZE : A4



THE INFORMATION CONTAINED HEREIN IS CONSIDERED 'PROPRIETARY' TO BEL FUSE INC. AND SHALL NOT BE COPIED, REPRODUCED OR DISCLOSED WITHOUT THE WRITTEN APPROVAL OF BEL FUSE INC.

RoHS



NOTES:

- PLASTIC HOUSING: THERMOPLASTIC PBT, BLACK  
FLAMMABILITY RATING UL 94V-0
- CONTACTS PLATING: 50 MICRO-INCH HARD GOLD PLATING OR EQUIVALENT.
- PINS: TIN-COATED COPPER WIRE, DIA 0.018 INCH.  
100 MICRO-INCH MIN MATTE TIN. PINS ARE SOLDER DIPPED.
- METAL SHIELD: NICKEL PLATED ON COPPER ALLOY.  
(ALL GROUND LEADS ARE SOLDER DIPPED)
- JACK CAVITY CONFORMS TO FCC RULES AND REGULATIONS.
- THE PRODUCT IS PATENTED. THE PATENT NUMBER IS U.S. PAT. 7,123,117.
- [1] MARK PART WITH MFG LOGO, MFG NAME, PART NUMBER  
DATE CODE AND PATENTED.

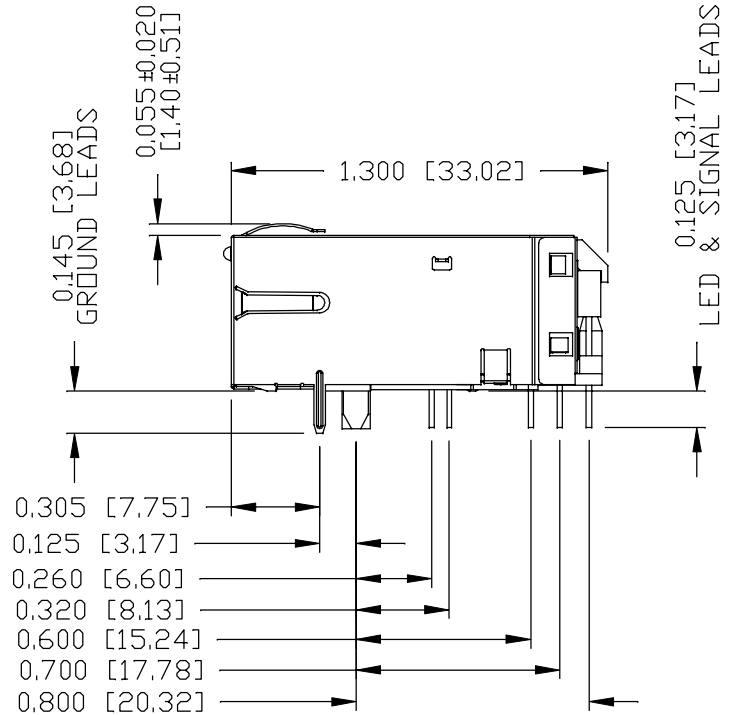
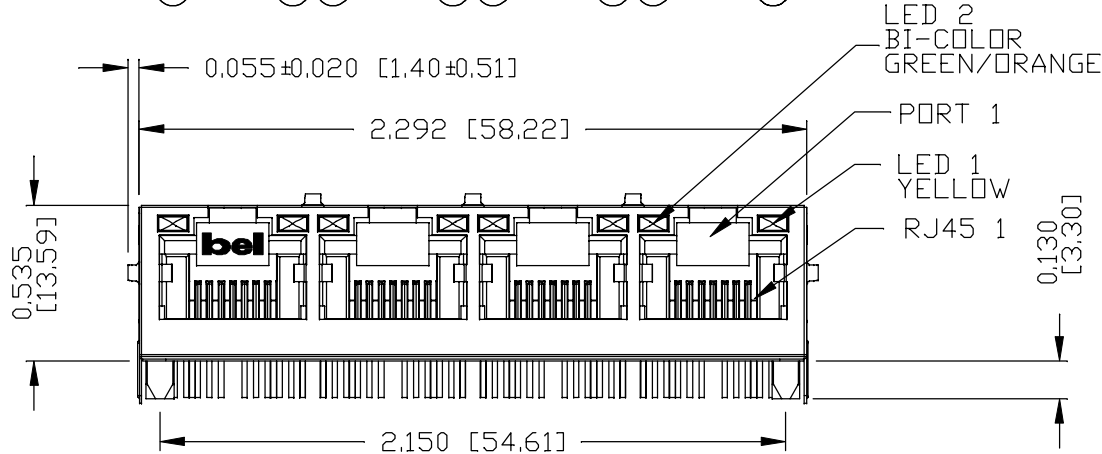
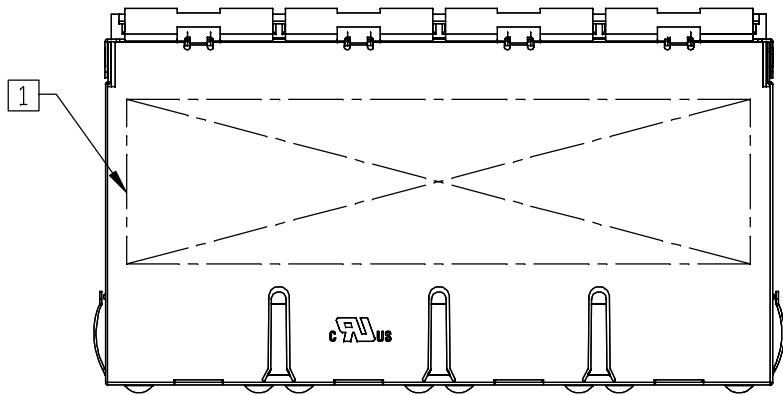

2. THE PRODUCT IS RoHS COMPLIANT.

**UL** UL RECOGNIZED - FILE #E196366 AND E169987.

3. THE PART IS RECOMMENDED FOR WAVE SOLDERING, THE SUGGESTED PEAK WAVE SOLDERING CONDITION IS 260°C MAX AND 10 SECONDS MAX.

ORIGINATED BY  
ANTON LIAO  
DATE 2017-04-03

DRAWN BY  
JESSE LI  
DATE 2017-04-03

TITLE  
1X4 glgabit MagJack®  
(PoEp, Extended Temperature)

0826-1X4T-GH-F  
PATENTED

PART NO. / DRAWING NO.  
08261X4TGH-F

FILE NAME  
08261X4TGH-F\_B.DWG

STANDARD DIM.  
TOL. IN INCH

.X	
.XX	
.XXX	±0.010

[ ] METRIC DIM.  
AS REF.

UNIT : INCH [mm]  
SCALE : N/A  
SIZE : A4

REV. : B

PAGE : 3

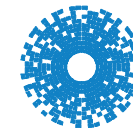

**bel** MAGNETIC SOLUTIONS  
a bel group

THE INFORMATION CONTAINED HEREIN IS CONSIDERED 'PROPRIETARY' TO BEL FUSE INC. AND SHALL NOT BE COPIED, REPRODUCED OR DISCLOSED WITHOUT THE WRITTEN APPROVAL OF BEL FUSE INC.

RoHS



RECOMMENDED PCB FOOTPRINT  
COMPONENT SIDE VIEW

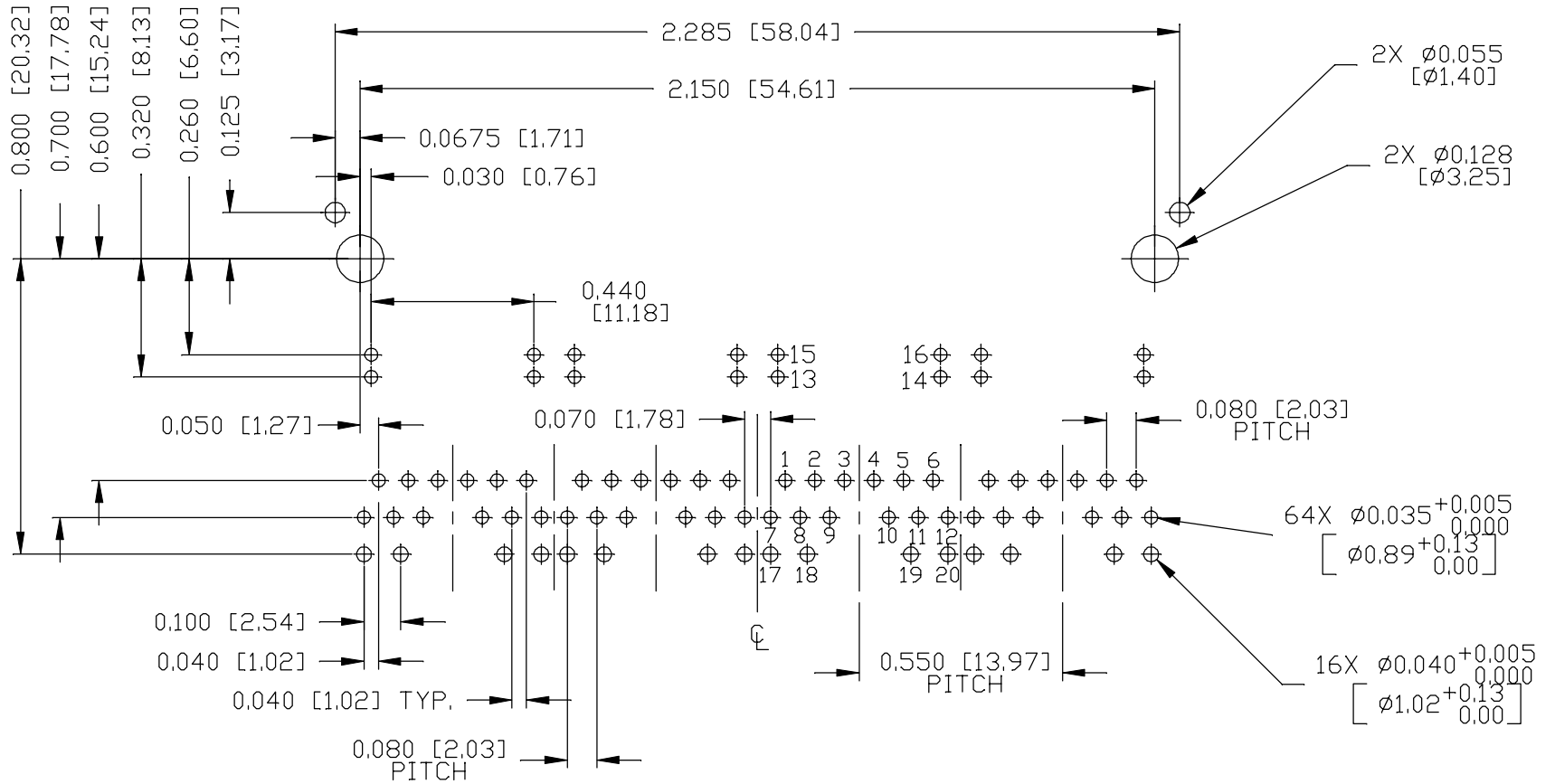

ORIGINATED BY  
ANTON LIAO  
DATE 2017-04-03  
DRAWN BY  
JESSE LI  
DATE 2017-04-03

TITLE  
1X4 glgabit MagJack®  
(PoEp, Extended Temperature)  
0826-1X4T-GH-F  
PATENTED

PART NO. / DRAWING NO.  
08261X4TGH-F  
FILE NAME  
08261X4TGH-F\_B.DWG

STANDARD DIM. TOL. IN INCH	[ ] METRIC DIM. AS REF.
.X	UNIT : INCH [mm]
.XX	SCALE : N/A
.XXX	SIZE : A4

REV. : B PAGE : 4

a bel group

THE INFORMATION CONTAINED HEREIN IS CONSIDERED "PROPRIETARY" TO BEL FUSE INC. AND SHALL NOT BE COPIED, REPRODUCED OR DISCLOSED WITHOUT THE WRITTEN APPROVAL OF BEL FUSE INC.

RoHS

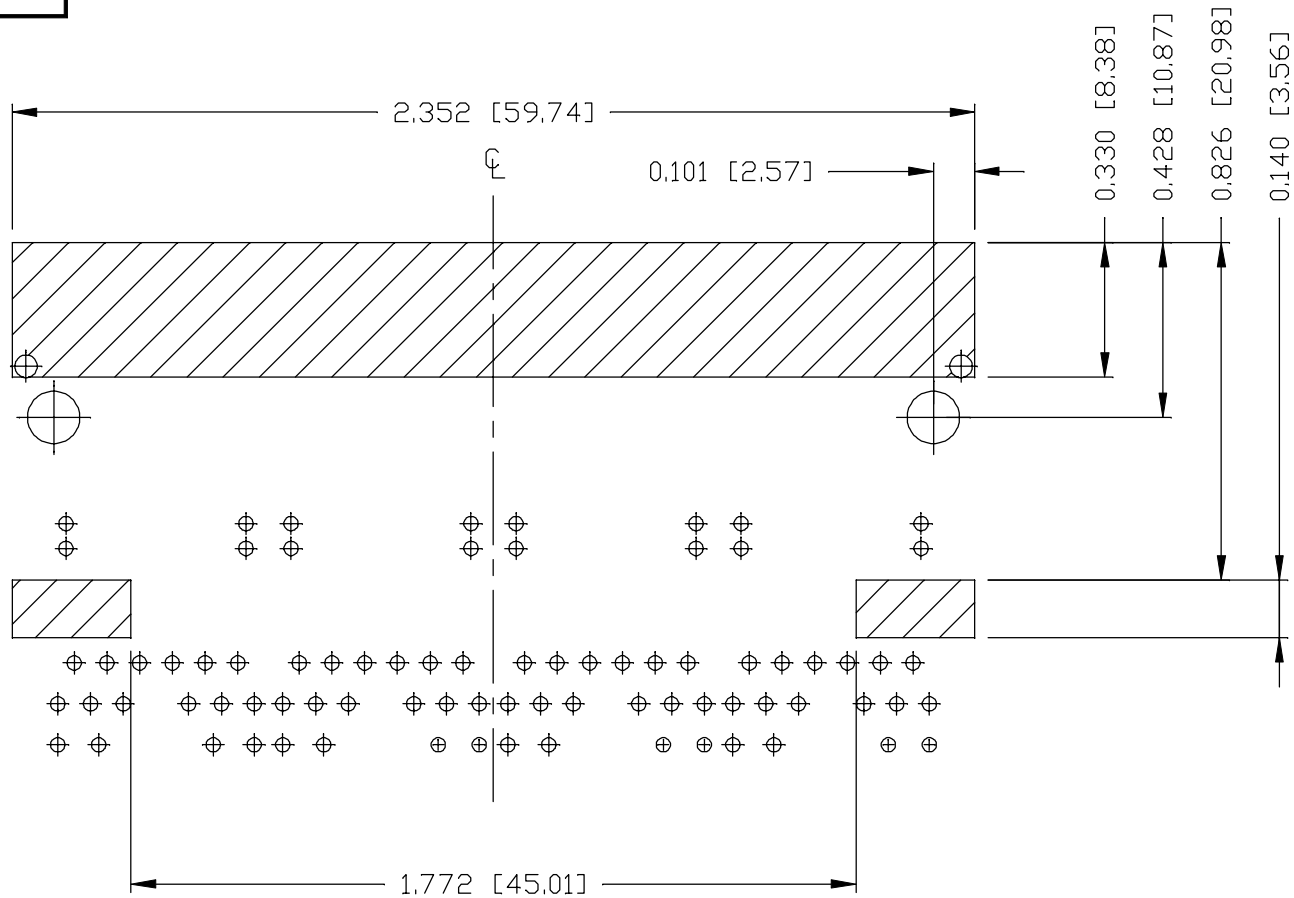

NOTES:

THE SHADED AREA ON THE CUSTOMER BOARD ARE RECOMMENDED TO BE CLEAR OFF ANY VIA HOLE OR COMPONENT PAD.

REV. : B PAGE : 5

ORIGINATED BY  
ANTON LIAO  
DATE 2017-04-03  
DRAWN BY  
JESSE LI  
DATE 2017-04-03

TITLE  
1X4 gigabit MagJack®  
(PoEp, Extended Temperature)  
0826-1X4T-GH-F  
PATENTED

PART NO. / DRAWING NO.  
08261X4TGH-F  
FILE NAME  
08261X4TGH-F\_B.DWG

STANDARD DIM. TOL. IN INCH	[ ] METRIC DIM. AS REF.
.X	UNIT : INCH [mm]
.XX	SCALE : N/A
.XXX	±0.004
	SIZE : A4



THE INFORMATION CONTAINED HEREIN IS CONSIDERED "PROPRIETARY" TO BEL FUSE INC. AND SHALL NOT BE COPIED, REPRODUCED OR DISCLOSED WITHOUT THE WRITTEN APPROVAL OF BEL FUSE INC.

RoHS



SUGGESTED PANEL OPENING

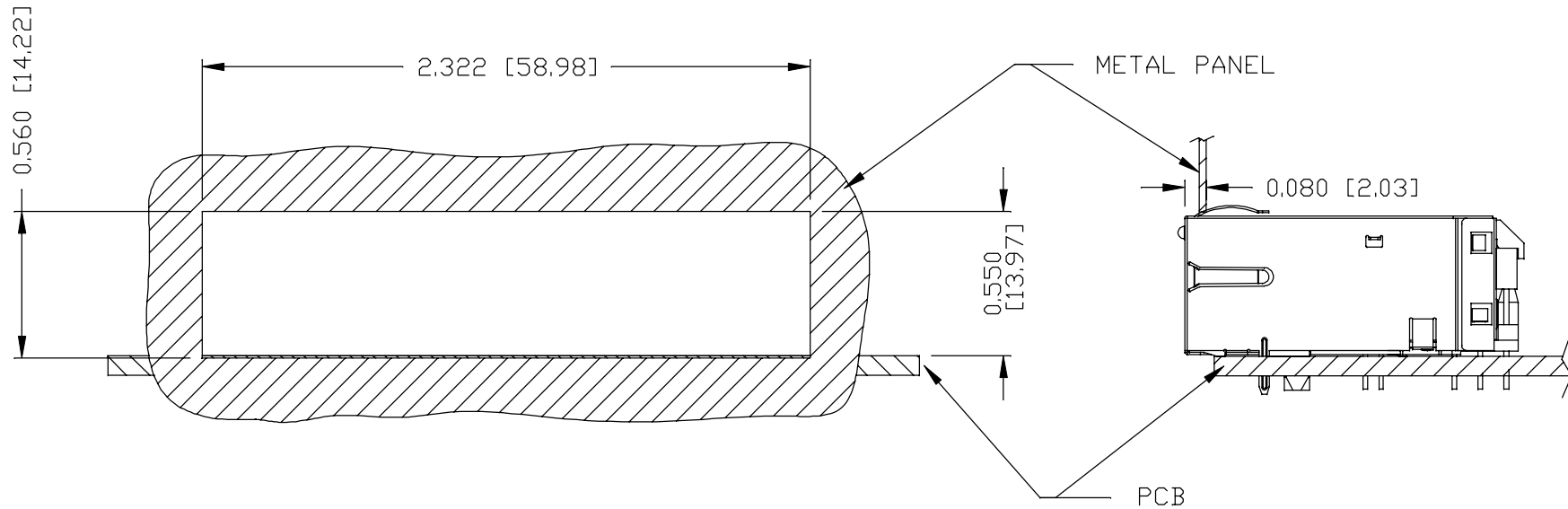

NOTES:

THE DISTANCE OF PANEL INSIDE SURFACE RELATIVE TO FRONT SURFACE OF PART IS ONLY A SUGGESTION. IN CASE THIS DISTANCE IS DIFFERENT, THE REQUIRED PANEL OPENING DIMENSIONS CHANGE ACCORDINGLY.

PACKING INFORMATION

PACKING TRAY : 0200-9999-B4 (TOP)

0200-9999-B5 (BOTTOM)

PACKING QUANTITY : 24 PCS FINISHED GOODS PER TRAY

10 TRAYS (240 PCS FINISHED GOODS) PER CARTON BOX

NOTE : CARDBOARDS ARE PLACED BETWEEN LAYERS OF PACKING TRAY INSIDE CARTON BOX

(INCLUDE THE UPPERMOST AND LOWERMOST TRAY)

REV. :	B	PAGE :	6
--------	---	--------	---

<b>ORIGINATED BY</b> ANTON LIAO <b>DATE</b> 2017-04-03	<b>TITLE</b> 1X4 gigabit MagJack® (PoEp, Extended Temperature) 0826-1X4T-GH-F PATENTED	<b>PART NO. / DRAWING NO.</b> 08261X4TGH-F <b>FILE NAME</b> 08261X4TGH-F_B.DWG	<b>STANDARD DIM. TOL. IN INCH</b> [ ] METRIC DIM. AS REF.			
			.X			UNIT : INCH [mm]
			.XX			SCALE : N/A
<b>DRAWN BY</b> JESSE LI <b>DATE</b> 2017-04-03			.XXX	±0.004	SIZE : A4	