

MICRO SPEAKER

Product No. 139045

BMS1609F-11C-07H03-DS

Issue no. BS/TE01.1713

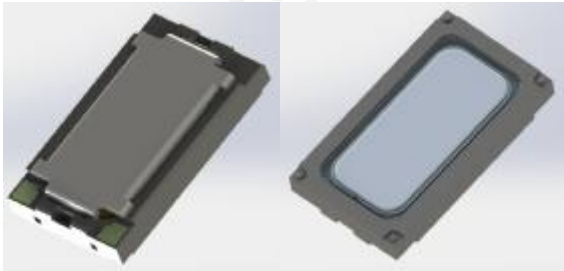

Features:

- No Welding
- HI-FI
- RoHS

BESTAR Holdings Co., Ltd.

www.be-star.com | info@be-star.com

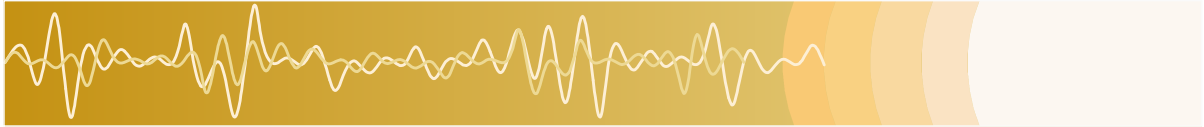

Content:

1 Characteristics	3
1.1 Technical terms	3
1.2 Test method	4
1.3 Frequency Response Curve	5
1.4 F0 Curve	6
1.5 Total Harmonic Distortion	7
1.6 R&B Curve	8
1.7 TSPParameter.....	9
1.8 Amplitude.....	9
2 Part List	10
3 Dimension	11
4 Reliability Test	12
5 Packing	13
5.1 Packing drawing	13
5.2 Packing quantity	13
6 History change record	14
7 Important Notice	15



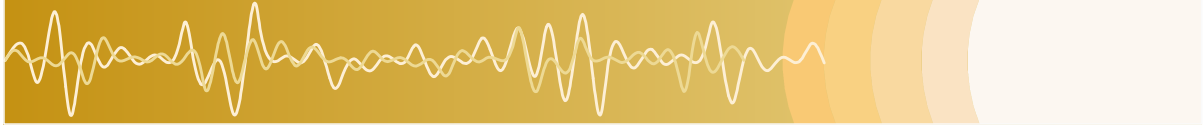

1.Characteristics

1.1 Technical terms

1. Size	16*9*H3.0mm
2. Impedance at 2KHz	$7\pm 20\%\Omega$
3. Lowest Resonance frequency	$850\pm 20\%Hz$
4. Rated input power	0.8W(in 1cc box)
5. Maximum input power	1.0W(in 1cc box)
6. Buzz & Rattle(at sine wave 2.53V)	must be normal between 300~3500Hz(in 1cc box)
7. SPL(0.8W 10cm sine wave)	$93\pm 3dB$ at 2KHz (in 1cc box)
8. THD(0.8W 10cm sine wave)	$\leq 35\%$ at 300-500Hz, $\leq 15\%$ at 800Hz, $\leq 10\%$ at 1KHz $\leq 5\%$ at 2-10KHz(0.8W / 0.1 m) (in 1.0cc box)
9. Weight	$\approx 1.5g$
10. Storage temperature	$-20\dots+70^{\circ}C$



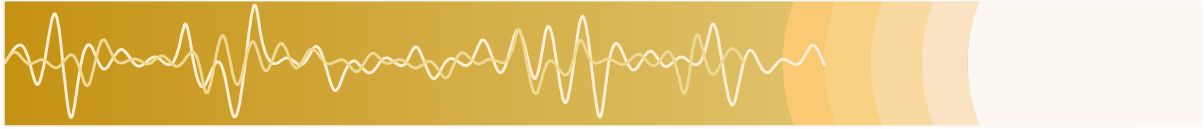

1.2 Test method:

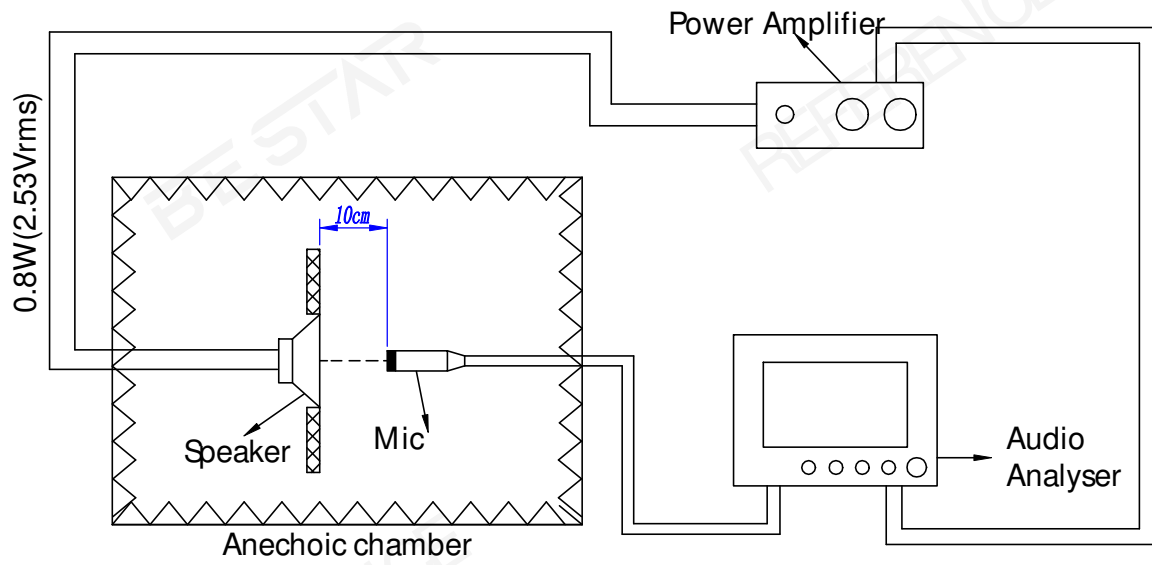

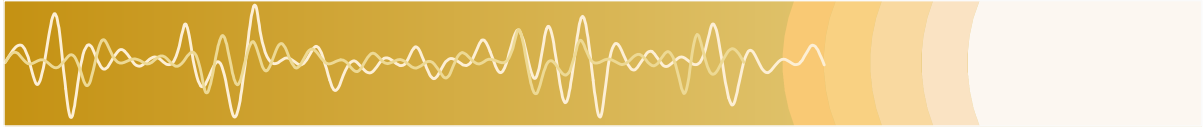

1.3 Frequency Response Curve (only for reference)

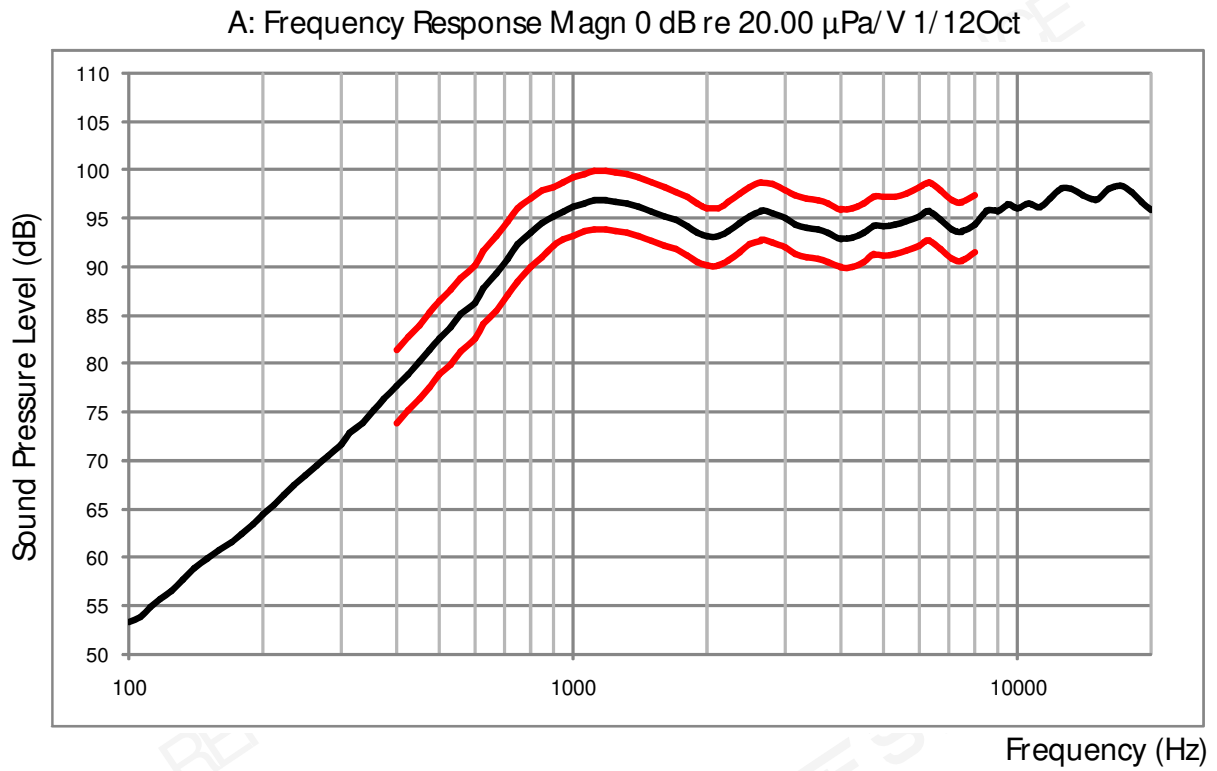

1.3.1 Sensitivity

SPL is expressed in dB rel 20 μ Pa, computed according to IEC 268-5.
Measurement set up according chapter 1.2 and parameters according chapter 1.3.



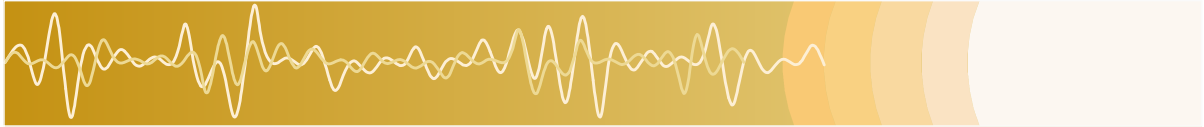

1.4 F0 Curve (only for reference)

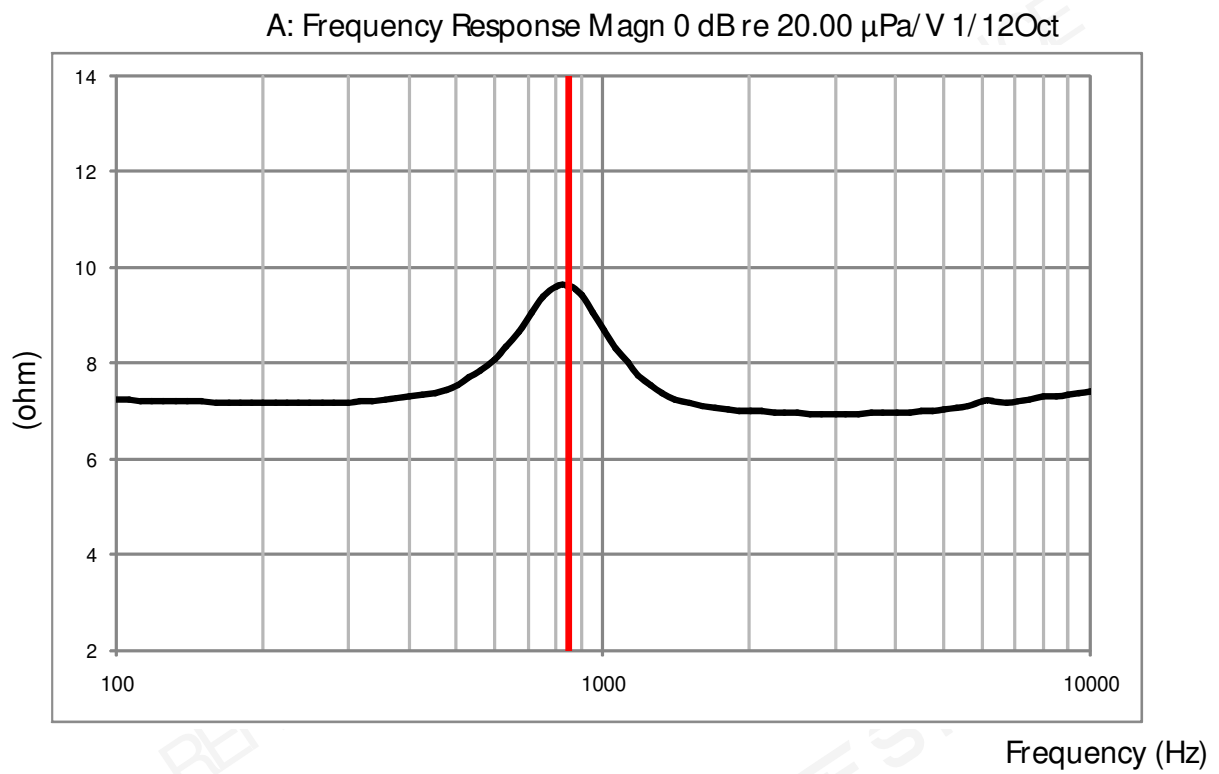

1.4.1 Resonance Frequency

Resonance frequency is measured according test set up in chapter 1.2 and parameters according chapter 1.4



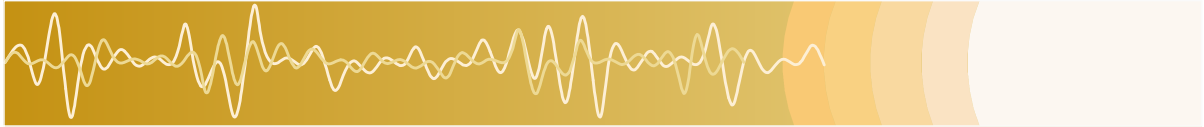

1.5 Total Harmonic Distortion (only for reference)

A: Frequency Response Magn 0 dB re 20.00 μ Pa/V 1/12Oct

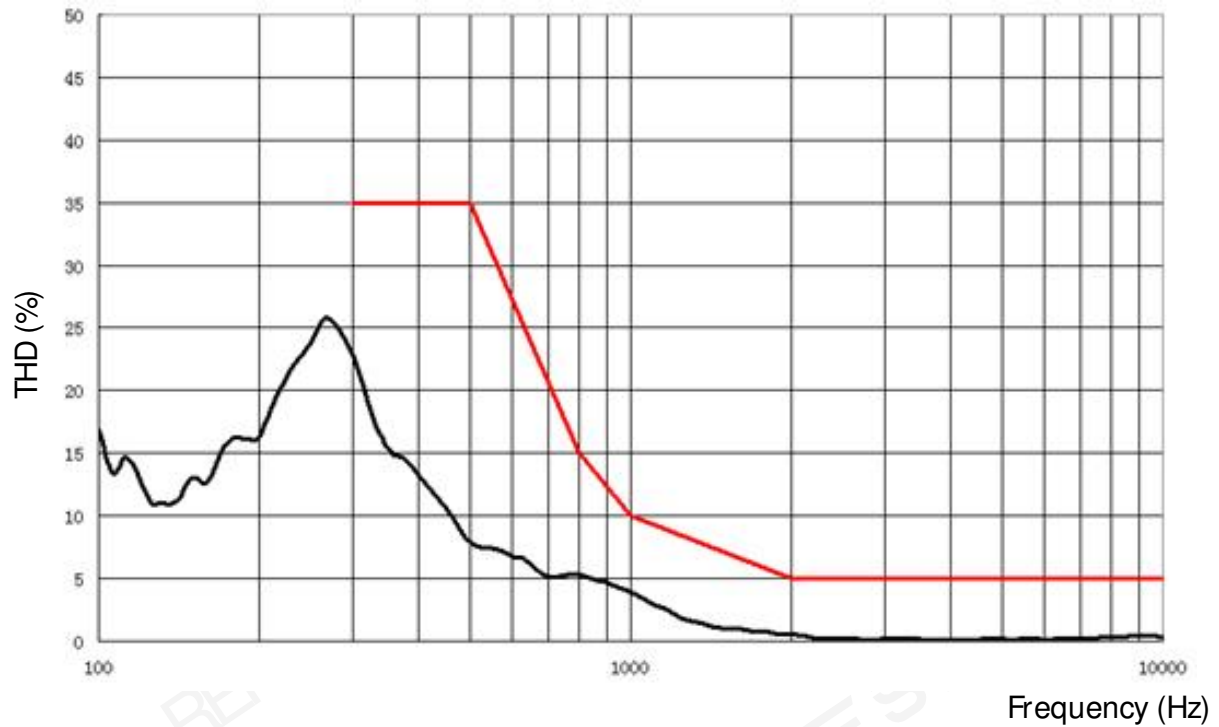

1.5.1 THD

THD is measured according test set up in chapter 1.2 and parameters according chapter 1.5



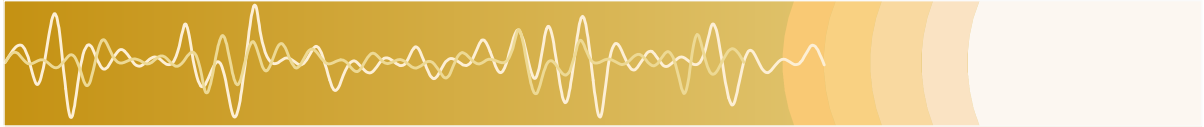

1.6 R&B Curve (only for reference)

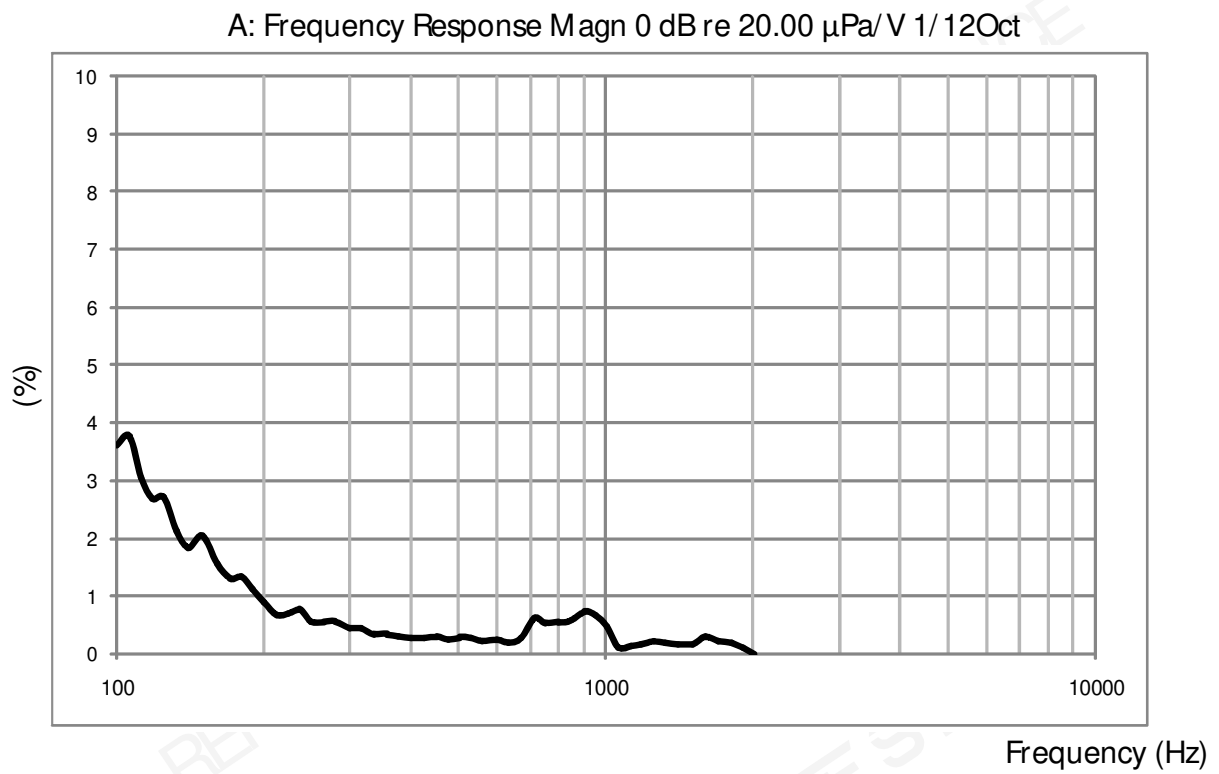

1.6.1 R&B

R&B is measured according test set up in chapter 1.2 and parameters according chapter 1.6



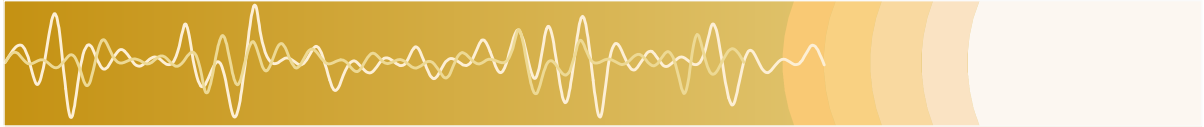

1.7 TSParameter (In 1cc box test)

Fs(Hz)	875	Rms(Kg/ s)	0.065
Re(Ohm)	7.1	BL(T/ m)	0.632
Le(mH)	0.026	Mms(g)	0.054
Cms(mm/ N)	0.475	Vas(L)	0.0005
Sd(mm^2)	90	Qms	5.187
Qts	2.533	Qes	4.951
Cmes(uF)	136.0	XMax(mm)	0.3

1.8 Amplitude (In 1cc box test)

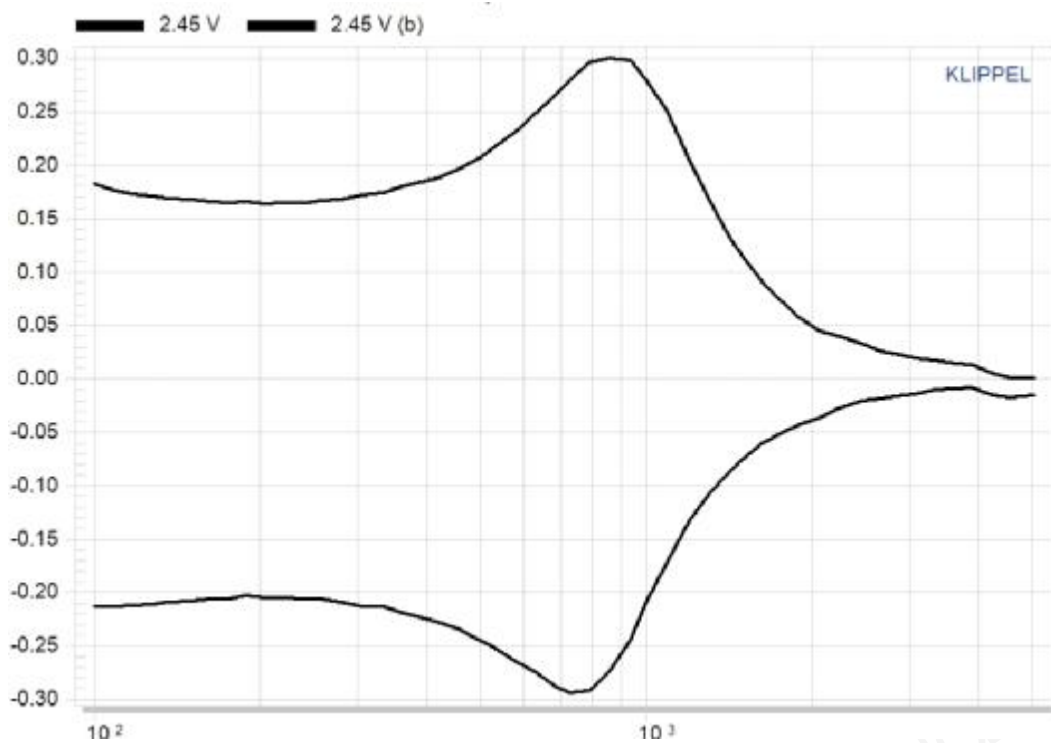

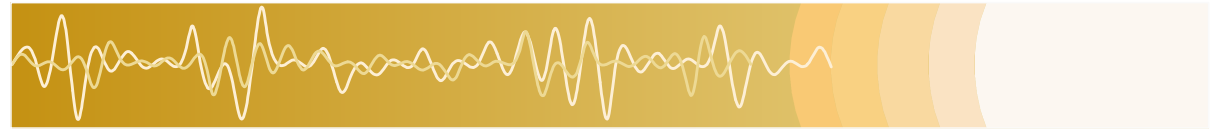

2.Part List

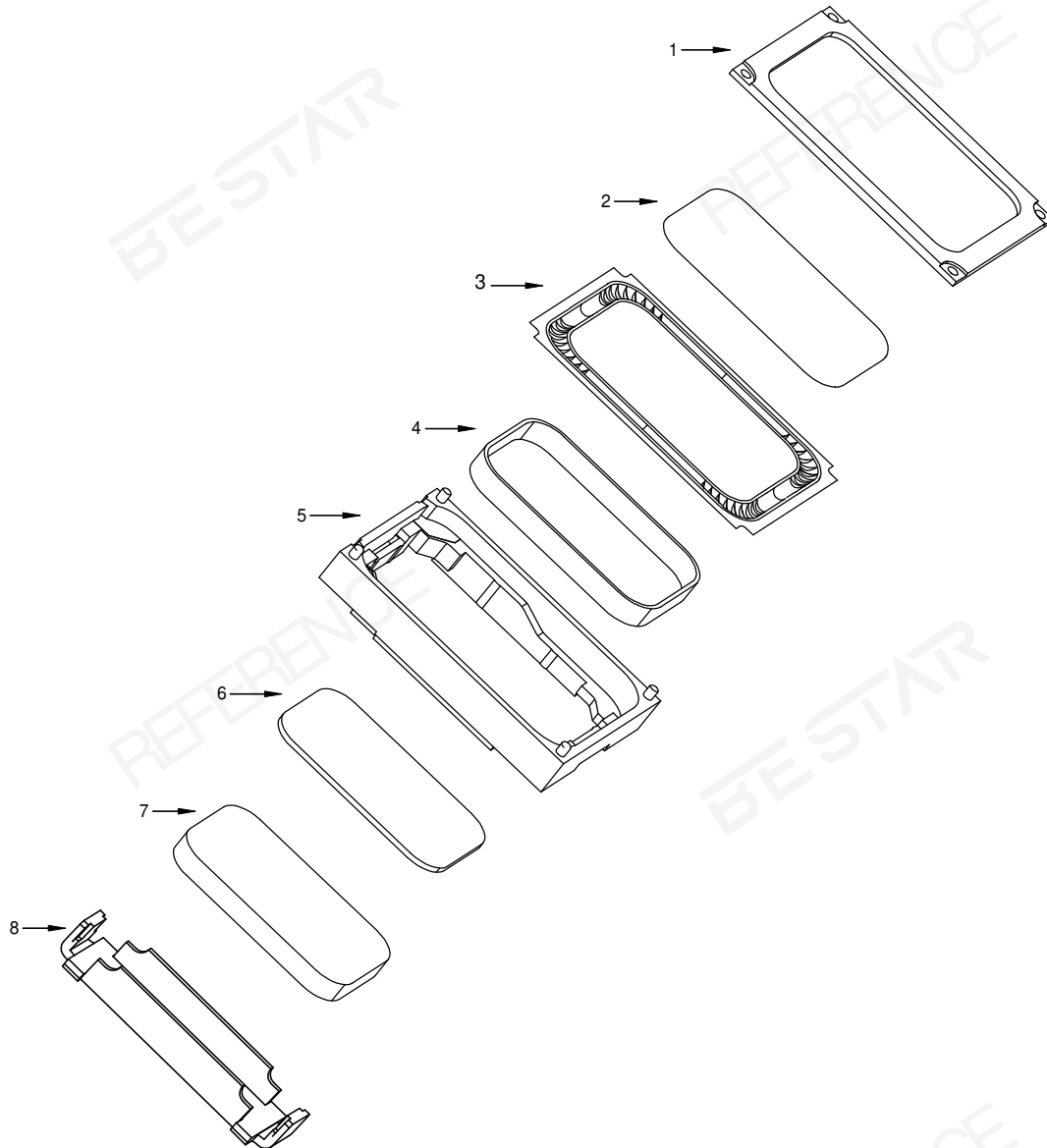

8. Yoke	SPOC
7. Magnet	NdFeB
6. Plate	SPOC
5. Frame	PPA
4. Voice coil	Cu
3. Diaphragm	Al Compound
2. Dome	Al Compound
1. Front cover	PPA



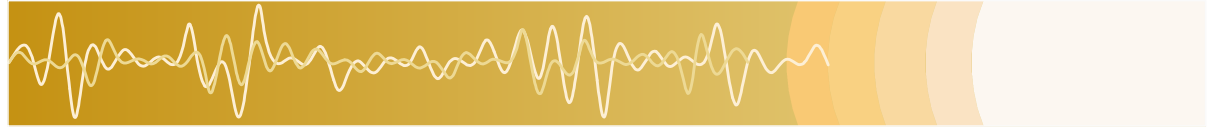

3. Dimension

Tolerance: $\pm 0.2\text{mm}$

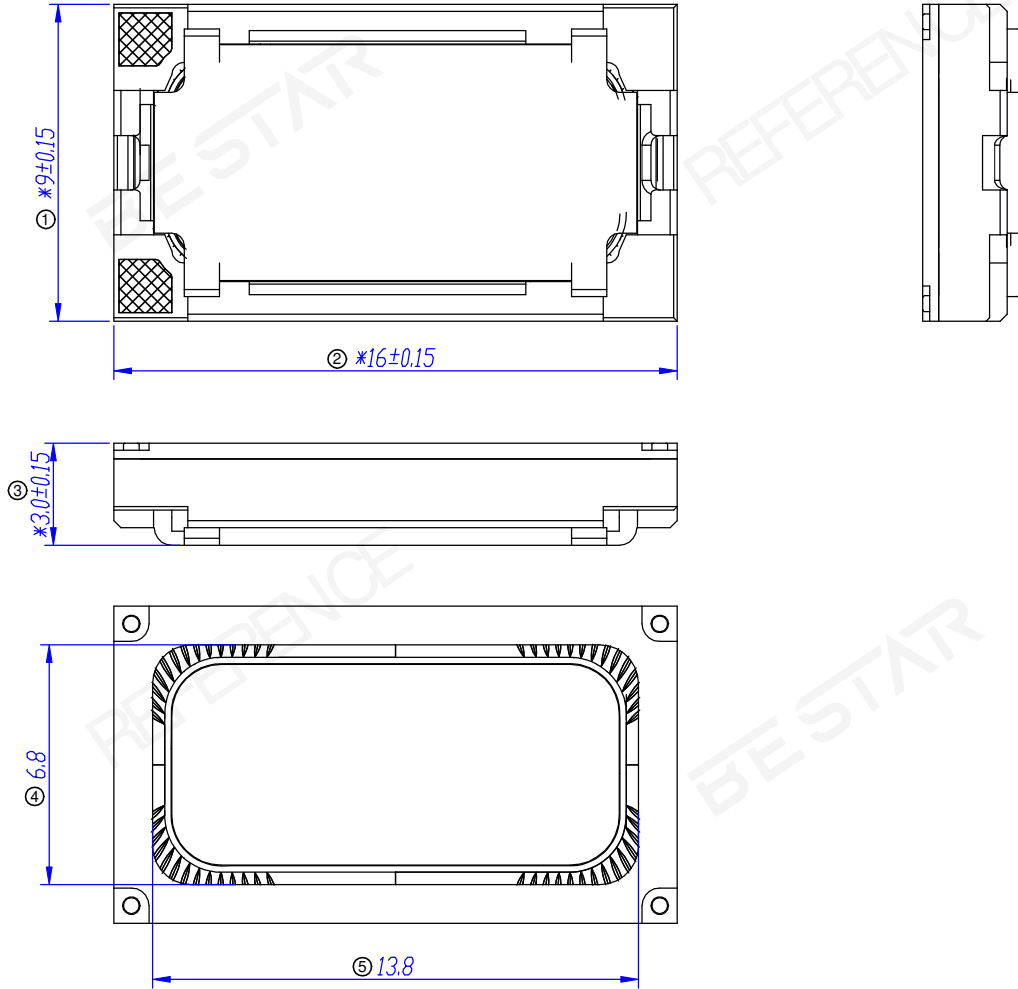

Speaker Front Cavity

Speaker Rear Cavity

Pull of Force on Yoke: 0N

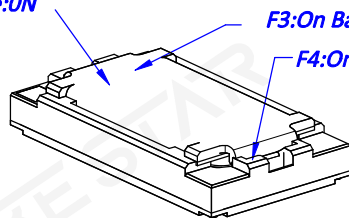

F3: On Back of Yoke

F4: On Back of Frame

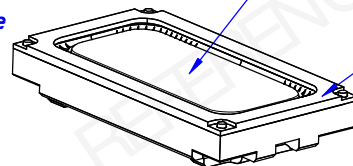

F1: On Diaphragm

F2: On Gasket Area

Max. Permitted Compression Forces			
NO	From	TO	Maximum Forces
1	F1		0N
2	F3	F2	10N
3	F4	F2	10N



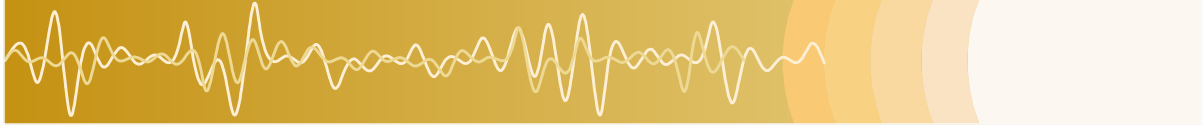

4. Reliability test

4.1 High temperature preservation test

Temperature +70°C
Duration 96hrs

4.2 Low temperature preservation test

Temperature -20°C
Duration 96hrs

4.3 Thermal shock test

Cycles 10

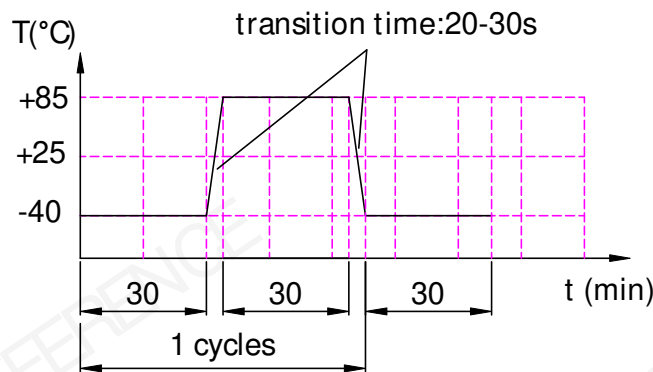

4.4 Damp Heat

Temperature 40±3°C
Relative Humidity 90%-95%RH
Duration 96hrs

4.5 Load Test

Power (Nom) 0.8W(in 1cc box)
Signal White noise/ F0~10KHz
Duration 96hrs

4.6 Drop Test

Height 1.0m(In the tooling)
Drop face thick ness wooden board (20mm)
Times three times in each direction

Notice:

1.Immediately after reliability test,the samples shall be stored under climatic conditions such as normally exist in ordinary rooms or laboratories.Unless otherwise noted,the recovery period shall be 4hrs at least before performance testing.After the waterproofing test, the sample should be stored immediately under the usual weather conditions in ordinary room or laboratory, and the test should be carried out 24 hours after recovery.

2.After any of the above tests the response at 2~5KHz shall not deviate more than ±3 dB from the initial value.



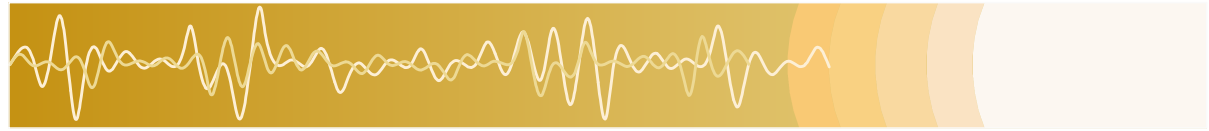

5. Packing

5.1 Packing drawing (unit:mm)

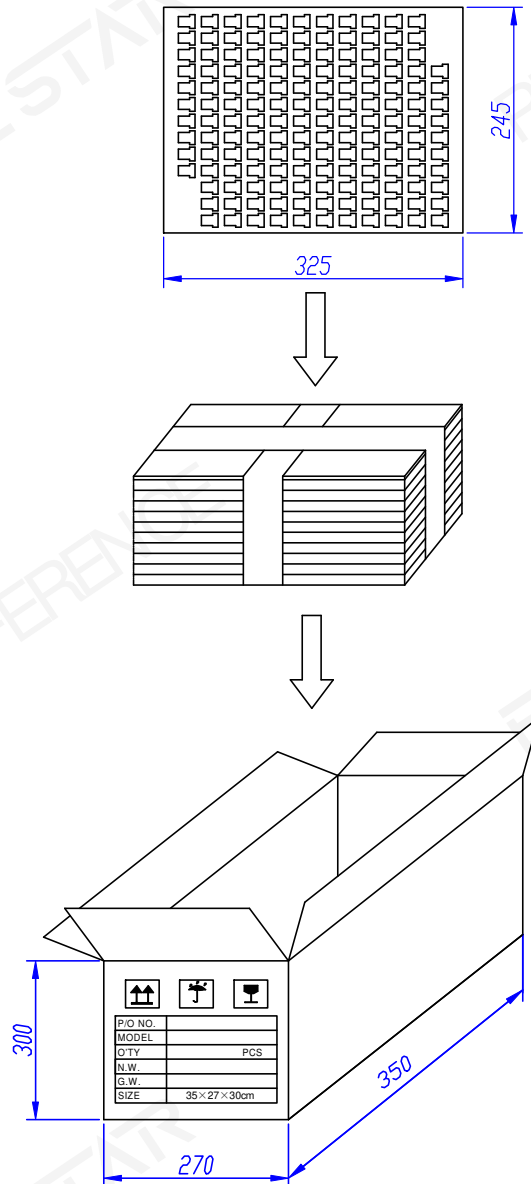

5.2 Packing quantity

- 1) 150pcs per carton
- 2) 24pcs carton per box
- 3) total 3600pcs per box,
- 4) carton size: 350X270X300mm



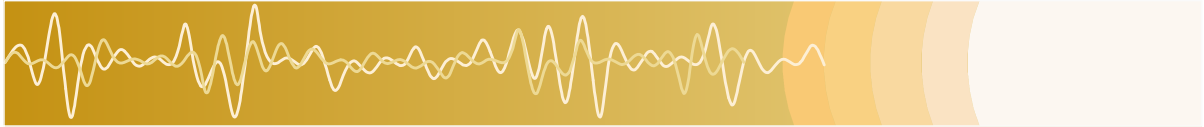

6. History change record

Version	Change Items	Date	Drawn	Checked	Approved
A	First Edition	2018.04.11	Emma. Pen	Judy. Yang	Jason. Zhang
B	Change the Rated Input Power	2018.05.07	Emma. Pen	Judy. Yang	Jason. Zhang
B1	Change specification template	2020.06.01	Emma. Pen	Peter. Huang	Jason. Zhang

REFERENCE

BESTAR

BESTAR

REFERENCE



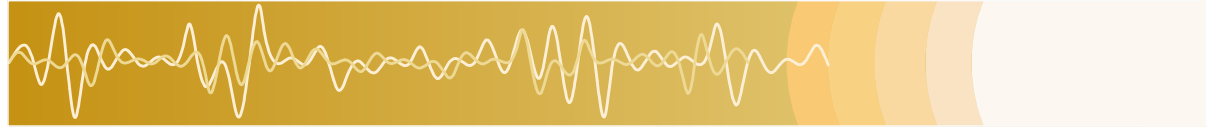

7. Important Notice

7.1 The products mustn't be washed

7.2 Storage Condition

The products should be stored in the room where the temperature/humidity is stable. And avoid such places where there are large temperature changes. Please store the products at the following conditions: Temperature: -10 to +40°C Humidity: 15 to 85%RH.

7.3 Expire Date on Storage

Expire date (Shelf life) of the products is six months after delivered under the conditions of a sealed and an unopened package. Please use the products within six months after delivered.

If you store the products for a long time (more than six months), use carefully because the products may be degraded in the solderability and/or rusty. Please confirm solderability and characteristics for the products regularly.

7.4 Notice on Product Storage

(1) Please do not store the products in a chemical atmosphere (Acids, Alkali, Bases, Organic gas, Sulfides and so on), because the characteristics may be reduced at quality, and/or be degraded in the solderability due to the storage in a chemical atmosphere.

(2) Please use the products immediately after the package is opened, because the characteristics may be reduced at quality, and/or be degraded in the solderability due to storage under the poor condition.

7.5 Rated and Max input power

Rated input power

Rated input power is the maximum (limit) value which can be input to the component intentionally. If the actual input power to component keeps exceeding Rated Input power, it will damage the component acoustic performances and reliability. In the worst case, the component will get broken and no sound.

Max input power

Max input power is the maximum (limit) value for unexpected input power which is caused in the customer's circuit like surge voltage. If the actual input power to component keeps exceeding Maximum input power, it will break the component and cause no sound in a short time. Please note that component will have a risk to get broken if the unexpected input power continues.

The value of input power is set based on the sinusoidal power in the normal speaker use. If the special signal is input to component, the values of Rated and Max input power will be different. Please make a well-investigation at your laboratory in the case of the special signal input.

