

PART NUMBER	REV	FIRST USED	TERMINATOR	FEED TYPE	DESCRIPTION
1529153-1	A		- BENCH & LEADMAKER	MECH POST FEED	HD-I APPLICATOR
7-1529153-1	A		- BENCH & LEADMAKER	MECH POST FEED	-1 AND SPARE PARTS
7-1529153-7	A		-	-	SPARE PARTS KIT

**CRIMP DATA** GROTE & HARTMANN TERMINAL GHW CRIMP SPECS

TERMINAL NAME: CLAW TERMINAL RING TYPE

CRIMP	SIZE	TYPE	RANGE
WIRE	3.30 [ .130 IN]	F $\Delta$	1.00-2.50mm <sup>2</sup>
INSUL	4.57 [ .180 IN]	OV $\Delta$	1.90-3.00 [ .075-.118 IN]
WIRE STRIP LENGTH		APPL INSTRUCTION	
5.25-6.05 [ .207-.239 IN]		408-8323 & 408-8490	

TERMINAL	FEED
APPL SPEC	29.90 [ 1.177 IN]

**TERMINALS APPLIED**

AMP PN	MFR PN	AMP PN	MFR PN	
1572499-1	25219.213.004	1572900-1	25221.123.011	-
1572499-2	25219.213.320	1572900-2	25221.213.011	-
1572499-3	25219.123.014	1572900-3	25221.212.179	-
1572499-4	25219.123.011	1572900-4	25221.214.009	-
1572499-5	25219.123.322	1572900-5	25221.214.321	-
1572499-6	25219.123.009	1572900-6	25221.122.323	-
1572499-7	25219.411.031	1572900-7	25221.123.014	-
		1572900-8	25221.123.009	-

WIRE SIZE mm <sup>2</sup> AWG	CRIMP HEIGHT	REF SETTING
2.50mm <sup>2</sup>	2.25 ±0.05 [ .089 ±.002 IN]	B 0
2.00mm <sup>2</sup>	2.15 ±0.05 [ .085 ±.002 IN]	C 0
1.50mm <sup>2</sup>	2.10 ±0.05 [ .083 ±.002 IN]	C 5
1.00mm <sup>2</sup>	1.95 ±0.05 [ .077 ±.002 IN]	D 1

- $\Delta$  RECOMMENDED SPARE PARTS.
- 2. GREASE RAM, CAM, CAM FOLLOWER AND FEED ROD LIGHTLY.
- 3. LUBRICATE DAILY PER THE APPLICATOR INSTRUCTION SHEET SUPPLIED WITH THE APPLICATOR.
- $\Delta$  WIRE CRIMP DATA SUPPLIED BY TERMINAL MANUFACTURER.
- $\Delta$  INSULATION CRIMP DATA CALCULATED BY TYCO ELECTRONICS LTD.

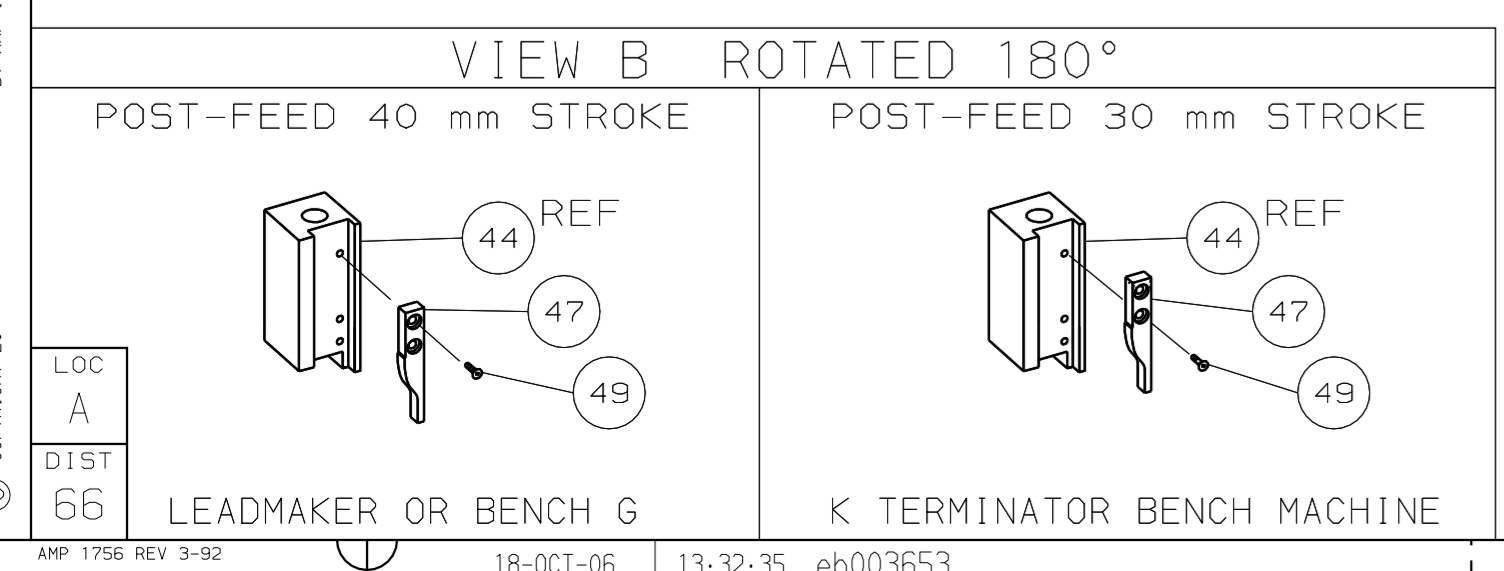

**\* WARNING:**  
ON INSTALLATION, SET WIRE DISC TO LARGEST WIRE SIZE SETTING.  
USE OF SETTINGS BELOW MIN REQ'D CRIMP HEIGHT SETTING WILL CAUSE DAMAGE TO CRIMP TOOLING.

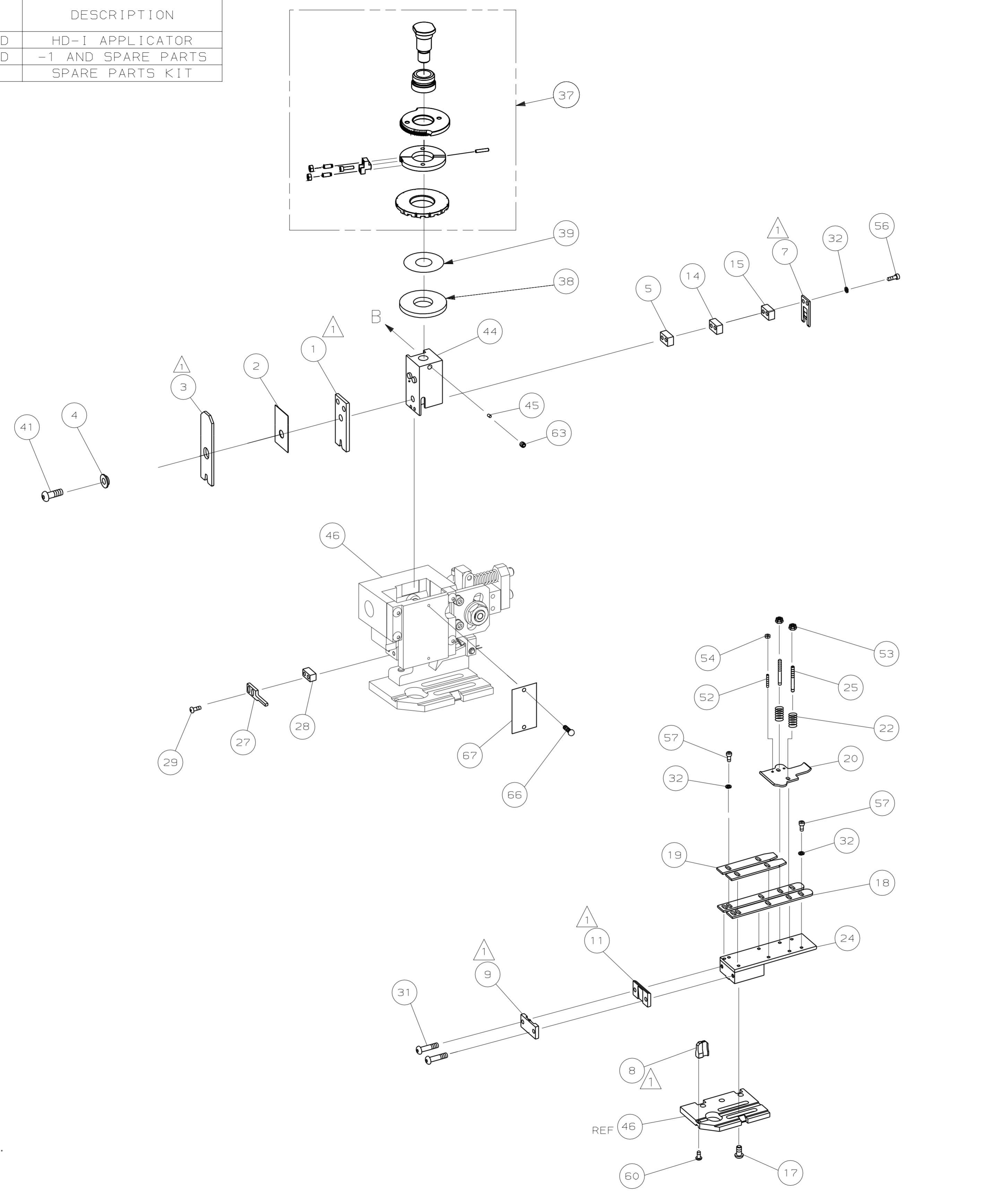

QTY	REQD	PER	ASSY	PART NO	DESCRIPTION	ITEM NO
-	1	1		1529153	PRINT, APPLICATOR LOG SHEET	73
-	1	1		1338705-4	DOCUMENTATION PACKAGE	72
						71
						70
						68
-	1	1		461264-5	PLATE, IDENTIFICATION	67
-	2	2		21017-2	SCR,DRIVE (#2X.19) ID PLATE	66
						65
						64
-	1	1		3-18031-0	SCR,SKT SET (M6X6) RAM	63
						62
						61
-	1	1		18024-7	SCR,BHC (M4X10) ANVIL	60
						59
						58
-	6	6		1-18023-0	SCR,SHC (M4X8) STRIP GUIDE	57
-	2	2		1-18023-4	SCR,SHC (M4X20) SLUG BLADE	56
						55
-	2	2		18029-1	NUT, HEX (M3) DRAG	54
-	2	2		986965-1	NUT, HEX SL (M4) DRAG STUD	53
-	2	2		2-18032-2	SCR,SKT SET (M3X10) DRAG	52
						51
						50
-	1	1		18024-3	SCR,BHC (M3X10) CAM	49
						48
-	1	1		1338676-1	CAM, POST-FEED 30 & 40 mm ST	47
-	1	1		1338662-1	APPLICATOR, BASIC (SUBASSY)	46
-	1	1		690191-1	PLUG, NYLON	45
-	1	1		1320998-1	RAM	44
						43
						42
-	1	1		2-18024-6	SCREW,BHC (M8X25) CRIMPER	41
						40
-	1	1		690125-1	SHIM SUBASSY	39
-	1	1		1-469367-0	SPACER, FINE ADJUST	38
-	1	1		879103-2	FINE ADJUST HEAD SUBASSY	37
						36
						35
						34
						33
-	8	8		18025-2	WASHER, LOCK (M4) SHEAR BL	32
-	2	2		1-18024-0	SCR,BHC (M4X20) SHEAR PL	31
						30
-	2	2		18024-8	SCR,BHC (M4X12) STRIPPER	29
-	1	1		3-690451-2	SPACER, STRIPPER	28
-	1	1		240639-1	STRIPPER	27
						26
-	2	2		1320906-1	DRAG, STUD	25
-	1	1		1-1320995-2	PLATE, STRIP GUIDE	24
						23
-	2	2		4-22281-1	SPRING, DRAG	22
						21
-	1	1		1338665-1	DRAG, STOCK	20
-	2	2		1338664-1	GUIDE, UPPER STRIP	19
-	2	2		1338663-4	GUIDE, LOWER STRIP	18
-	4	4		1-18024-8	SCR,BHC (M6X12) STRIP 6D PL	17
						16
-	1	1		7-240641-1	SPACER, SLUG BLADE	15
-	1	1		1-240641-1	SPACER, SLUG BLADE	14
						13
						12
$\Delta$	-	1	1	240644-9	PLATE, REAR SHEAR	11
						10
$\Delta$	-	1	1	690482-4	PLATE, FRONT SHEAR	9
$\Delta$	1	2	1	1-1333221-6	ANVIL	8
$\Delta$	-	1	1	690474-4	BLADE, SLUG	7
						6
-	1	1		2-240641-5	SPACER, SLUG BLADE	5
-	1	1		238009-2	SPACER, BLOCK CRIMPER	4
$\Delta$	1	2	1	1-854830-9	CRIMPER, INSULATION	3
$\Delta$	-	1	1	455888-5	SPACER, CRIMPER	2
$\Delta$	1	2	1	3-456410-2	CRIMPER, WIRE	1

DIMENSIONS: mm [INCHES]		MATL	HT TR	FIN
DO NOT SCALE PRINT.				
TOLERANCES UNLESS OTHERWISE SPECIFIED:				
1 PLC DEC ±				
2 PLC DEC ±				
3 PLC DEC ±				
ANGLES ±				
SURF TEXTURE: $\checkmark$				
REMOVE BURRS, BREAK SHARP EDGES RO.38 MAX				

DR	10MAY05	APP	10MAY05	F.BACKHURST
L.L.OFTHOUSE				
CHK		REL	17MAY05	L.L.OFTHOUSE

NAME	MACHINE REF
FINE ADJ END FD HD-I APPL	HD-I APPL

SCALE	DWG NO	1529153	SHEET 1 OF 1	REV A1
-	D			

CAGE CODE 00779 CUSTOMER AND ASSEMBLY DRAWING

THIS DRAWING IS A CONTROLLED DOCUMENT.

LAYOUT L1529106  
SET UP GAGE 458638-3

RELEASER FOR PUBLICATION  
BY AMP INCORPORATED. ALL RIGHTS RESERVED.

AMP 1756 REV 3-92