

1: DATA2  
 2: CD/DAT3  
 3: CMD  
 4: VDD  
 5: CLK  
 6: VSS  
 7: DAT0  
 8: DAT1

503182-0832	503182-0822	503182-08**
EMBOSSED TAPE	MATERIAL NO.	MODEL NO.
ORDER No. オーダー番号		

RELEASED EC NO: J2009-2810 DRWN: YNAITO 2009/06/15 CHKD: MTOMITA 2009/06/15 APPR: MSASAO 2009/06/15	GENERAL TOLERANCES (UNLESS SPECIFIED)		DIMENSION STYLE MM ONLY		SCALE 4:1	DESIGN UNITS METRIC	THIRD ANGLE PROJECTION
	10 UNDER	± 0.2	DRAWN BY	DATE	TITLE		
	10 OVER 30 UNDER	± 0.25	CHECKED BY	DATE	MICRO SD CARD CONN. NORMAL ULTRA LOW-PRO ASSY		
	30 OVER	± 0.3	APPROVED BY	DATE	MOLEX INCORPORATED		
ANGULAR ± 1 °	DRAFT WHERE APPLICABLE MUST REMAIN WITHIN DIMENSIONS		SEE CHART		DOCUMENT NO.		SHEET NO.
				THIS DRAWING CONTAINS INFORMATION THAT IS PROPRIETARY TO MOLEX INCORPORATED AND SHOULD NOT BE USED WITHOUT WRITTEN PERMISSION		SD-503182-005	

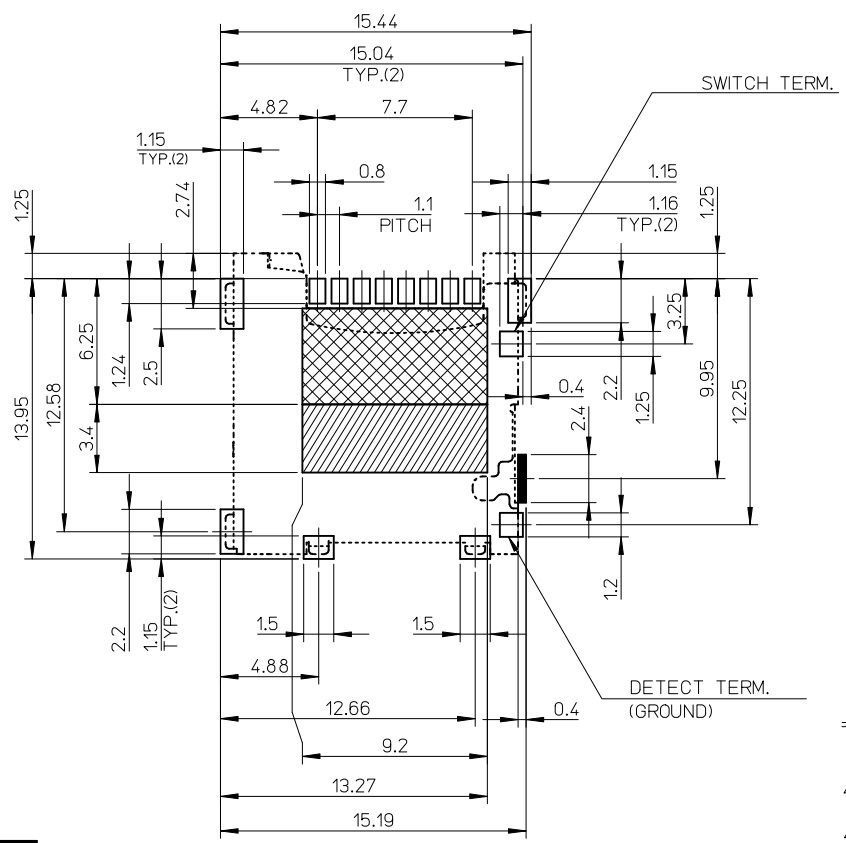

番号 No.	名称 NAME	材料 MATERIAL
①	ハウジング HOUSING	液晶ポリマー(LCP) LIQUID CRYSTAL POLYMER (LCP)
②	ターミナル TERMINAL	銅合金、接点部：金めっき 半田付部：錫めっき 下地：ニッケルめっき COPPER ALLOY, CONTACT AREA:GOLD TAIL AREA:TIN UNDER PLATING:NICKEL
③	メタルシェル METAL SHELL	ステンレス鋼、半田付け部：金めっき 下地：ニッケルめっき STAINLESS STEEL, TAIL AREA:GOLD UNDER PLATING:NICKEL
④	カムスライダー CAM SLIDER	液晶ポリマー(LCP) LIQUID CRYSTAL POLYMER (LCP)
⑤	ディテクトネイル DETECT NAIL	銅合金、接点部：金めっき 半田付部：金めっき 下地：ニッケルめっき COPPER ALLOY, CONTACT AREA:GOLD TAIL AREA:GOLD UNDER PLATING:NICKEL
⑥	スイッチネイル SWITCH NAIL	銅合金、接点部：金めっき 半田付部：金めっき 下地：ニッケルめっき COPPER ALLOY, CONTACT AREA:GOLD TAIL AREA:GOLD UNDER PLATING:NICKEL
⑦	スプリング SPRING	ピアノ線 SWP
⑧	カムピン CAM PIN	ステンレス鋼 STAINLESS STEEL

CONFIDENTIAL

NOTES

1. ターミナル及びネイルの平坦度は0.1MAX.とする。  
COPLANARITY OF TERMINAL AND NAIL IS TO BE 0.1MAX.
2. スタンドオフ寸法  
DIMENSIONS OF STAND OFF.
3. ロット印字は任意とする  
LOT NUMBERING IS TO BE OPTIONAL.
4. 肉抜き位置は任意とする。  
CAVITY IS TO BE OPTIONAL.
5. カード検知スイッチ  
DETECT SWITCH

6. ELV及びRoHS適合品  
ELV AND ROHS COMPLIANT.
7. 本製品は、カード仮保持力軽減品です。  
TYPE:  
WITHDRAWAL FORCE REDUCTION  
FROM PRE-LOCK POSITION.

カード挿入時 CARD INSERTING POSITION	クローズ CLOSED
カード未挿入時 NO CARD POSITION	オープン OPEN

ロットNo. : 7 7 0 7 0  
 西暦(1桁目) : 7 : 7月  
 THE YEAR OF GRACE A : 10月  
 B : 11月  
 C : 12月  
 月 MONTH  
 日 DAY  
 ラインNo. LINE No.  
 07 : 07日

SEE SHEET 1 OF 2 EC NO: J2009-2810 DRWN:YNAITO 2009/06/15 CHKD:MTOMITA 2009/06/15 APPR:MSASAO 2009/06/15	GENERAL TOLERANCES (UNLESS SPECIFIED)	DIMENSION STYLE MM ONLY	SCALE 4:1	DESIGN UNITS METRIC	THIRD ANGLE PROJECTION
	10 UNDER ±0.2	DRAWN BY YNAITO	DATE 2009/06/01	TITLE MICRO SD CARD CONN. NORMAL ULTRA LOW-PRO ASSY	
	10 OVER 30 UNDER ±0.25	CHECKED BY MTOMITA	DATE 2009/06/01	MOLEX INCORPORATED	
	30 OVER ±0.3	APPROVED BY MSASAO	DATE 2009/06/01	DOCUMENT NO. SD-503182-005	SHEET NO. 2 OF 2
ANGULAR ±1 °	DRAFT WHERE APPLICABLE MUST REMAIN WITHIN DIMENSIONS		THIS DRAWING CONTAINS INFORMATION THAT IS PROPRIETARY TO MOLEX INCORPORATED AND SHOULD NOT BE USED WITHOUT WRITTEN PERMISSION		

引き出し方向  
PULL OUT DIRECTION

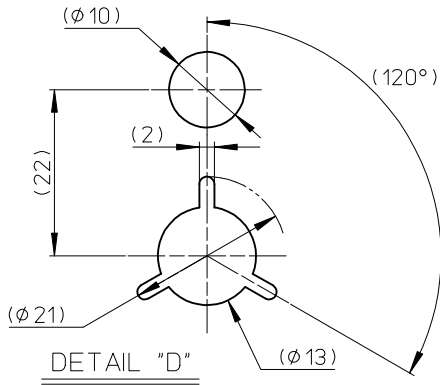
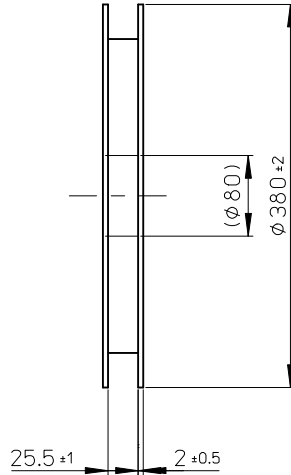
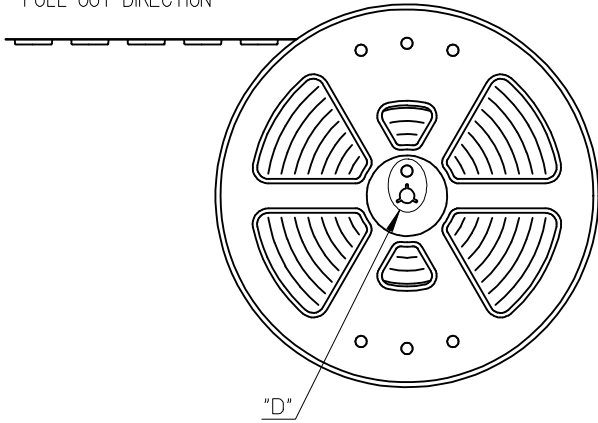

NOTES

- 製品詳細寸法は製品単体図面を参照して下さい。  
FOR DETAIL OF CONNECTOR DIMENSIONS, PLEASE SEE THE DRAWING OF CONNECTOR ITSELF (NOT PACKAGED).
- 梱包数量：1600個/リール  
NUMBER OF CONNECTORS : 1600 PCS/REEL.
- リードテープ長さ LEAD TAPE LENGTH.

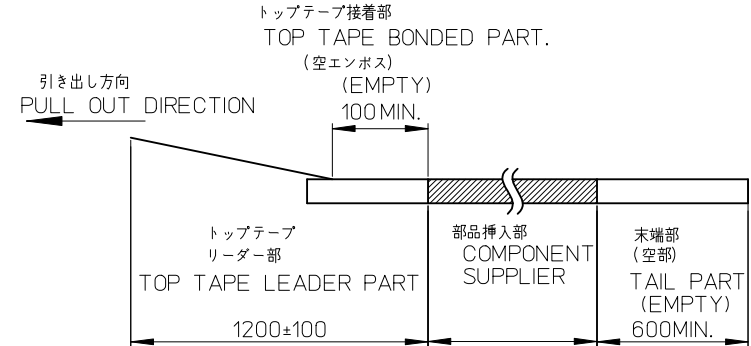

- 材料 MATERIAL  
キャリアテープ(CARRIER TAPE) : ポリスチレン (POLYSTYRENE)  
トップテープ(TOP TAPE) : PET, PE, PEF  
リール(REEL) : ポリスチレン(PS)<リサイクル材含む>  
POLYSTYRENE (PS)<RECYCLE MATERIAL CONTAINED>
- ELV AND RoHS COMPLIANT

503182-0822	503182-0832	503182-08**
CONNECTOR ONLY		MODEL NO.

RELEASED EC NO: J2009-2810 DRWN: YNAITO 2009/06/15 CHKD: MTOMITA 2009/06/15 APPR: MSASAO 2009/06/15	GENERAL TOLERANCES (UNLESS SPECIFIED)		DIMENSION STYLE MM ONLY		SCALE ---	DESIGN UNITS METRIC	THIRD ANGLE PROJECTION
	10 UNDER	± 0.2	DRAWN BY YNAITO	DATE 2009/06/01	TITLE MICRO SD CONN. ULTRA LOW-PRO EMBOSSED TAPE PACKAGE		
	10 OVER 30 UNDER	± 0.25	CHECKED BY MTOMITA	DATE 2009/06/01	MOLEX INCORPORATED		
	30 OVER	± 0.3	APPROVED BY MSASAO	DATE 2009/06/01	DOCUMENT NO. SD-503182-006		
A	ANGULAR ± 1 °	DRAFT WHERE APPLICABLE MUST REMAIN WITHIN DIMENSIONS		SIZE A3	THIS DRAWING CONTAINS INFORMATION THAT IS PROPRIETARY TO MOLEX INCORPORATED AND SHOULD NOT BE USED WITHOUT WRITTEN PERMISSION		SHEET NO. 1 OF 2

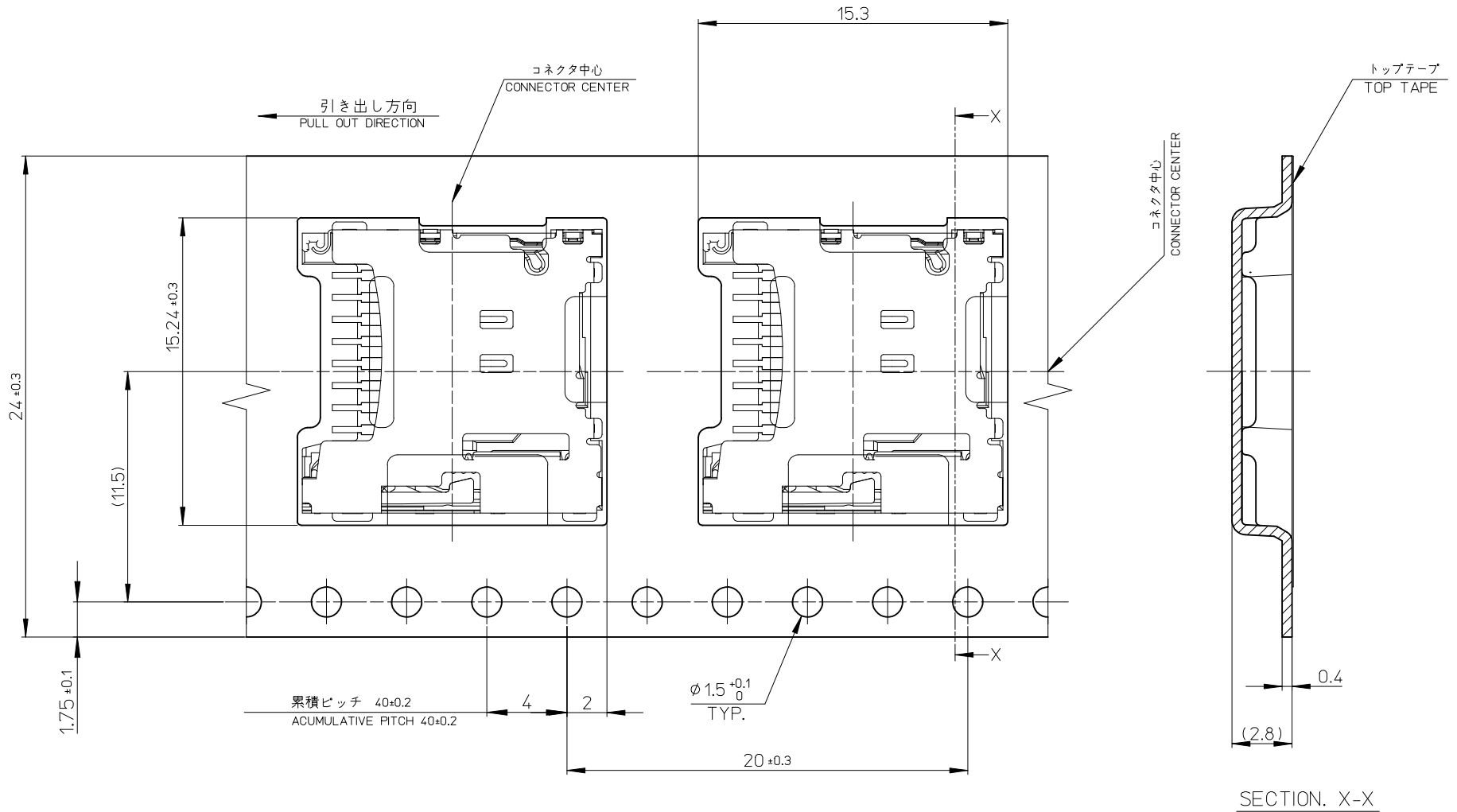

SECTION. X-X

SEE SHEET 1 OF 2 EC NO: J2009-2810 DRWN:YNAITO 2009/06/15 CHKD:MTOMITA 2009/06/15 APPR:MSASAO 2009/06/15	GENERAL TOLERANCES (UNLESS SPECIFIED)		DIMENSION STYLE MM ONLY		SCALE ---	DESIGN UNITS METRIC	THIRD ANGLE PROJECTION		
	10 UNDER	±0.2	DRAWN BY YNAITO	DATE 2009/06/01	TITLE MICRO SD CONN. ULTRA LOW-PRO EMBOSSED TAPE PACKAGE				
	10 OVER 30 UNDER	±0.25	CHECKED BY MTOMITA	DATE 2009/06/01	MOLEX INCORPORATED				
	30 OVER	±0.3	APPROVED BY MSASAO	DATE 2009/06/01	DOCUMENT NO. SD-503182-006				
ANGULAR ±1 °	DRAFT WHERE APPLICABLE MUST REMAIN WITHIN DIMENSIONS	MATERIAL NO. SEE SHEET 1 OF 2		SHEET NO. 2 OF 2					
SIZE A3	THIS DRAWING CONTAINS INFORMATION THAT IS PROPRIETARY TO MOLEX INCORPORATED AND SHOULD NOT BE USED WITHOUT WRITTEN PERMISSION								