

- 1 HOUSING MATERIAL: GLASS-FILLED POLYMER.
- 2 CONTACT MATERIAL: COPPER ALLOY.
- 3 CONTACT FINISH: DIN 41612 CLASS 2 IN CONTACT AREA. TIN PLATE ON POSTS.
- 4 PART NUMBER, DATE CODE IDENTIFICATION, CSA LOGO IN THIS APPROXIMATE AREA.
- 5 CONTACT POINT.
- 6 RECOMMENDED HOLE SIZE FOR MANUAL APPLICATION OF CONNECTOR ONTO PC BOARD.

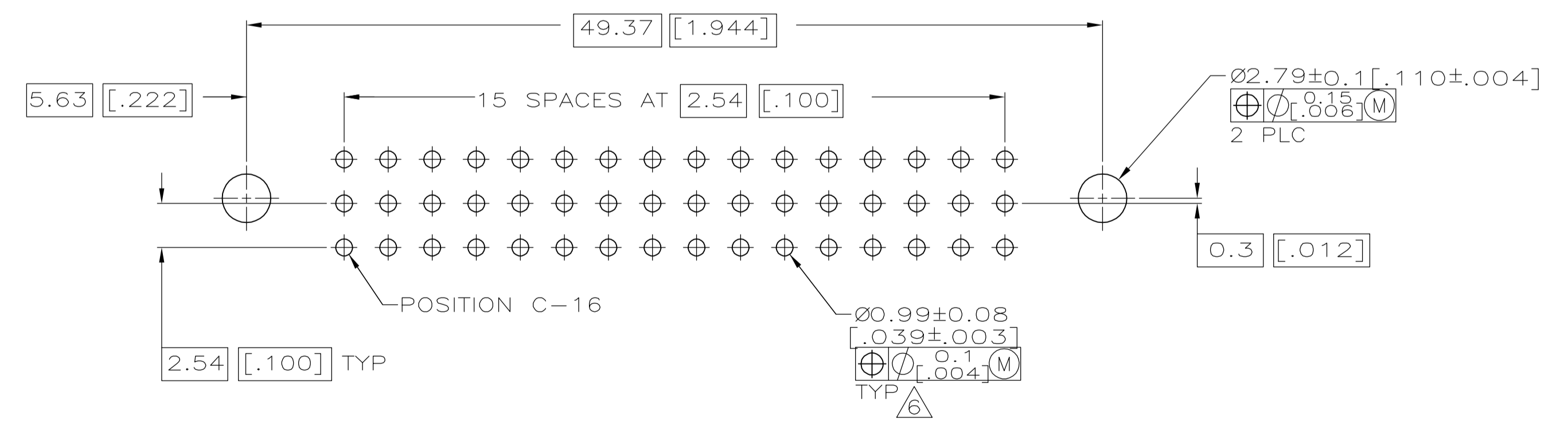
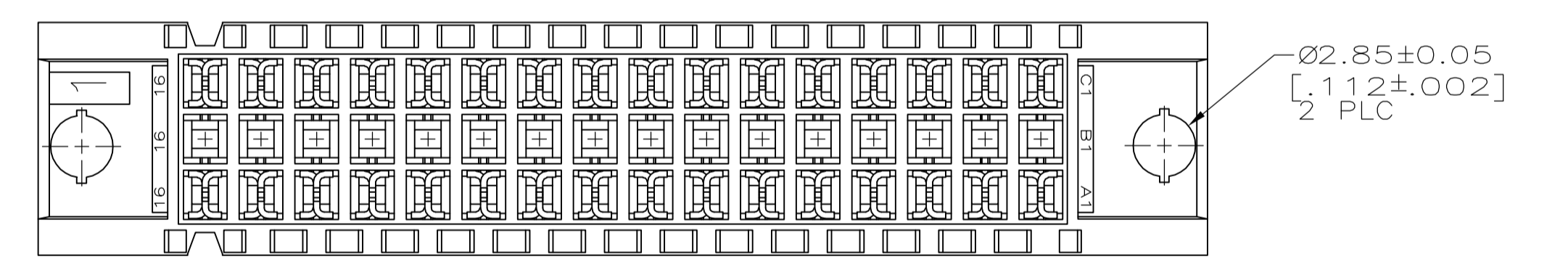
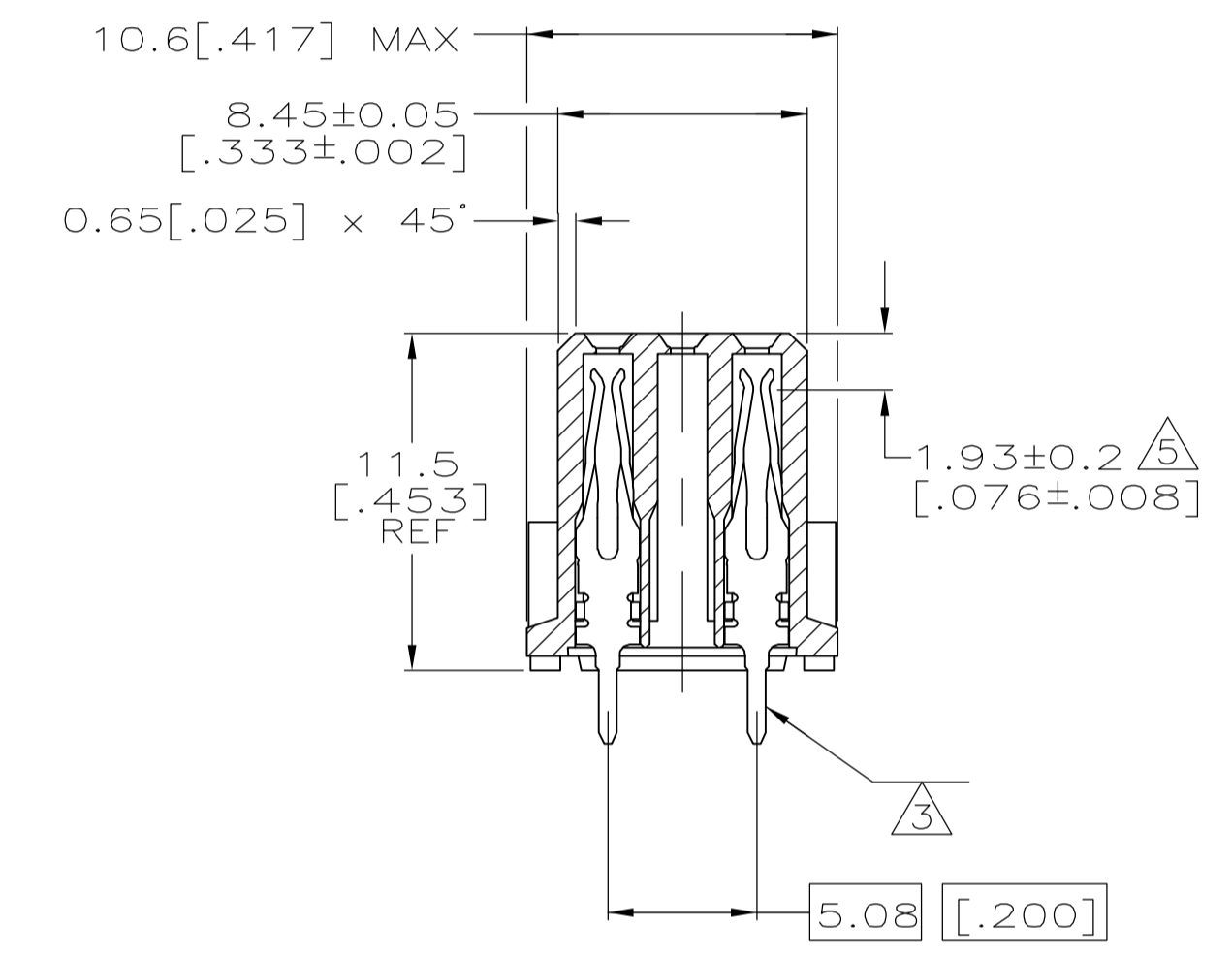
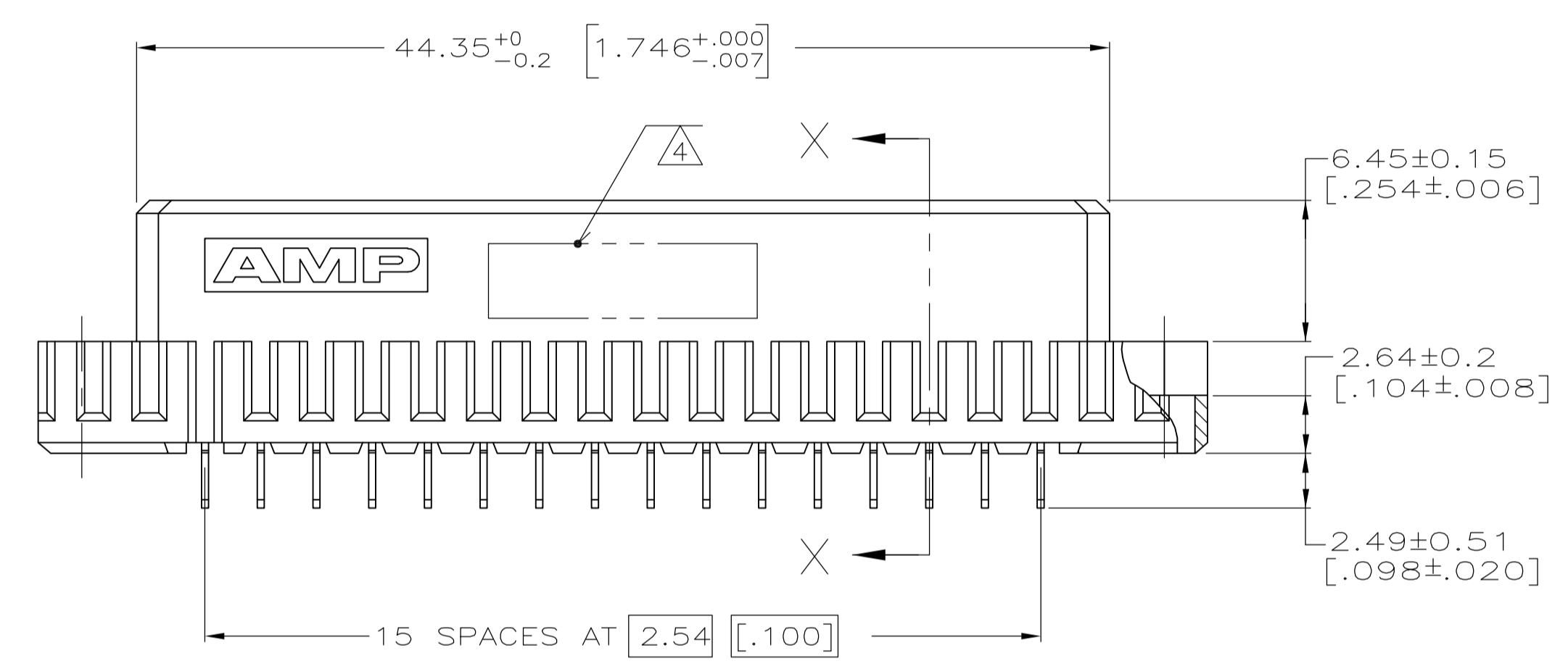
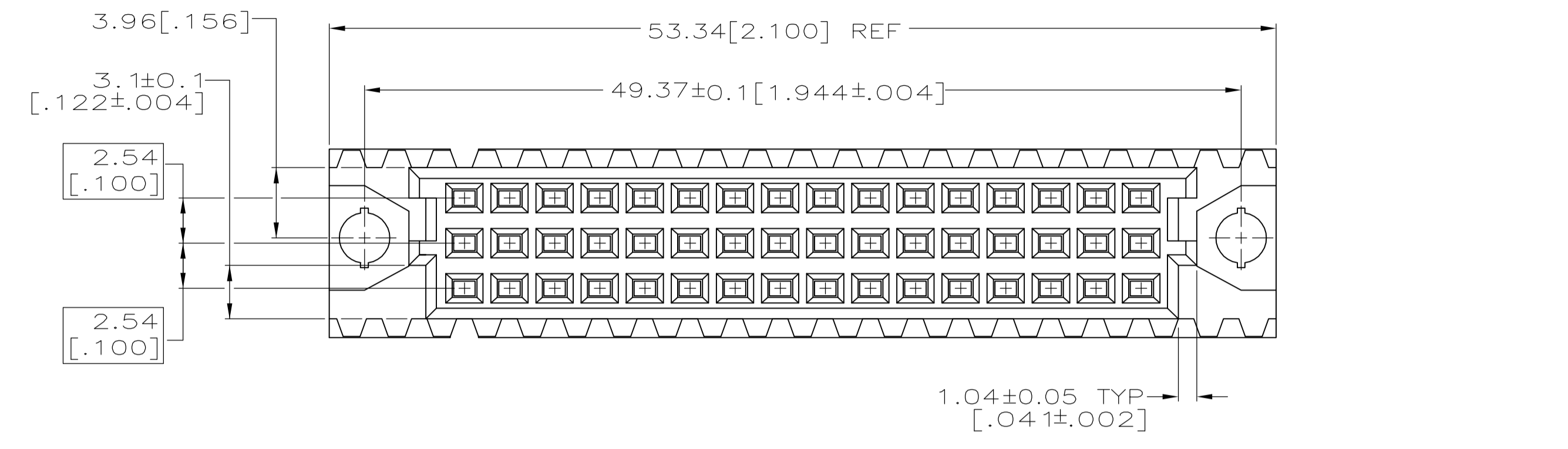

PC BOARD LAYOUT

1 THRU 16	X - X	32	5650459-5
POSITIONS LOADED	ROWS LOADED	NO. OF LOADED POSITION	ASSY PART NUMBER

THIS DRAWING IS A CONTROLLED DOCUMENT.		DIN J. POLIGNONE 27MAY05		Tyco Electronics Corporation	
DIMENSIONS: mm [INCHES]		CIK A. SHARPE 27MAY05		Harrisburg, PA 17105-3608	
TOLERANCES UNLESS OTHERWISE SPECIFIED:		APVO A. SHARPE 27MAY05		NAME ASSEMBLY, RECEPTACLE, EUROCARD, TYPE 1/2C, A and C, 32/48 POSITION, 2.49 [.098] SOLDER POSTS	
0 PLC ± -	1 PLC ± -	2 PLC ± -	3 PLC ± 0.13 [.005]	4 PLC ± -	ANGLES ± -
MATERIAL		FINISH		SIZE	SCALE
1 2		3		A1	4:1
CUSTOMER DRAWING		DRAWING NO. 00779		SHEET 1 OF 1	