



ANATECH ELECTRONICS INC
RF & Microwave Filters & Products

DC-4300 MHz / 4700-9000 MHz Microstrip Line Diplexer

Part Number: AE4300-4700DB5452



<u>Characteristics</u>	<u>Band 1 (RX)</u>	<u>Band 2 (TX)</u>
Passband:	DC-4300 MHz	4700-9000MHz
Insertion Loss:	≤ 1.0dB	≤ 1.0dB
Crossover Insertion Loss:	≤ 5.0dB	≤ 5.0dB
Crossover Frequency Offset:	±2.5%	±2.5%
Return Loss:	≥ 10.88dB	≥ 10.88dB
Rejection: >50dB	5100-8000 MHz	DC-3900 MHz
Power Handling:	20 Watts	20 Watts

<u>Mechanical</u>	
Mounting Method:	2.8 mm Through Holes
Connector Type:	SMA (F)
Dimensions:	2.23 x 1.77 x 0.47 inches

<u>Environmental</u>	
Operating Temperature:	-40 to +75deg.C
Storage Temperature:	-50 to +85deg.C

Outline Drawing:

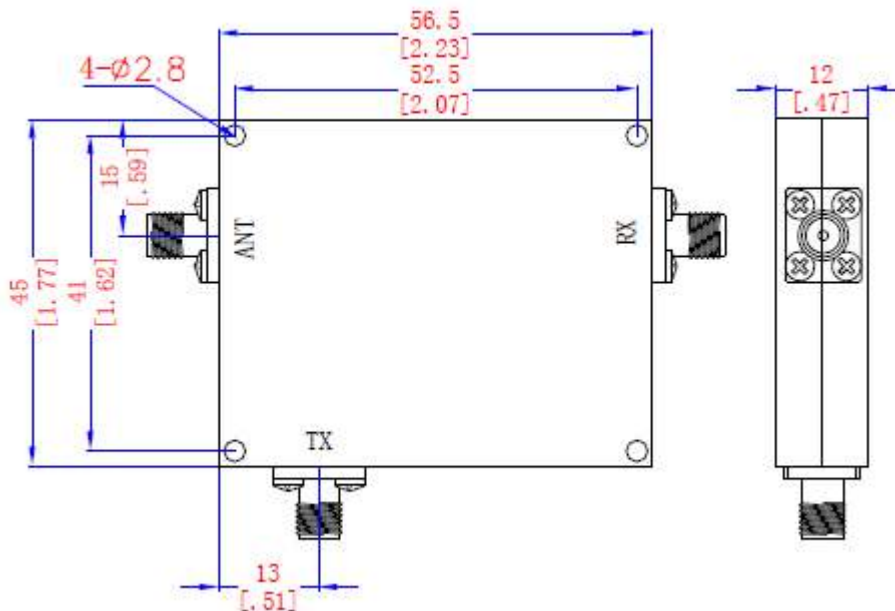

Reference DCR: D050719-02A

Tolerance: ± 0.3mm