

DRAWING MADE IN THIRD ANGLE PROJECTION  
 THIS DRAWING IS UNPUBLISHED. RELEASED FOR PUBLICATION .19  
 © COPYRIGHT 19 BY AMP INCORPORATED, HARRISBURG, PA. ALL INTERNATIONAL RIGHTS RESERVED. AMP PRODUCTS MAY BE COVERED BY U.S. AND FOREIGN PATENTS AND/OR PATENTS PENDING.

REVISIONS									
LOC	DIST	P	F	ZONE	LTR	DATE	APPD		
5049	DF	AO						0	RELEASED
								A	REV PER ECN DF-0770 TW
						3-89			EJH

BOTH DESCRIPTIVE & NUMERICAL (ORDERING)  
 PART NO. INKSTAMPED 1.19 [.047] MIN. HIGH

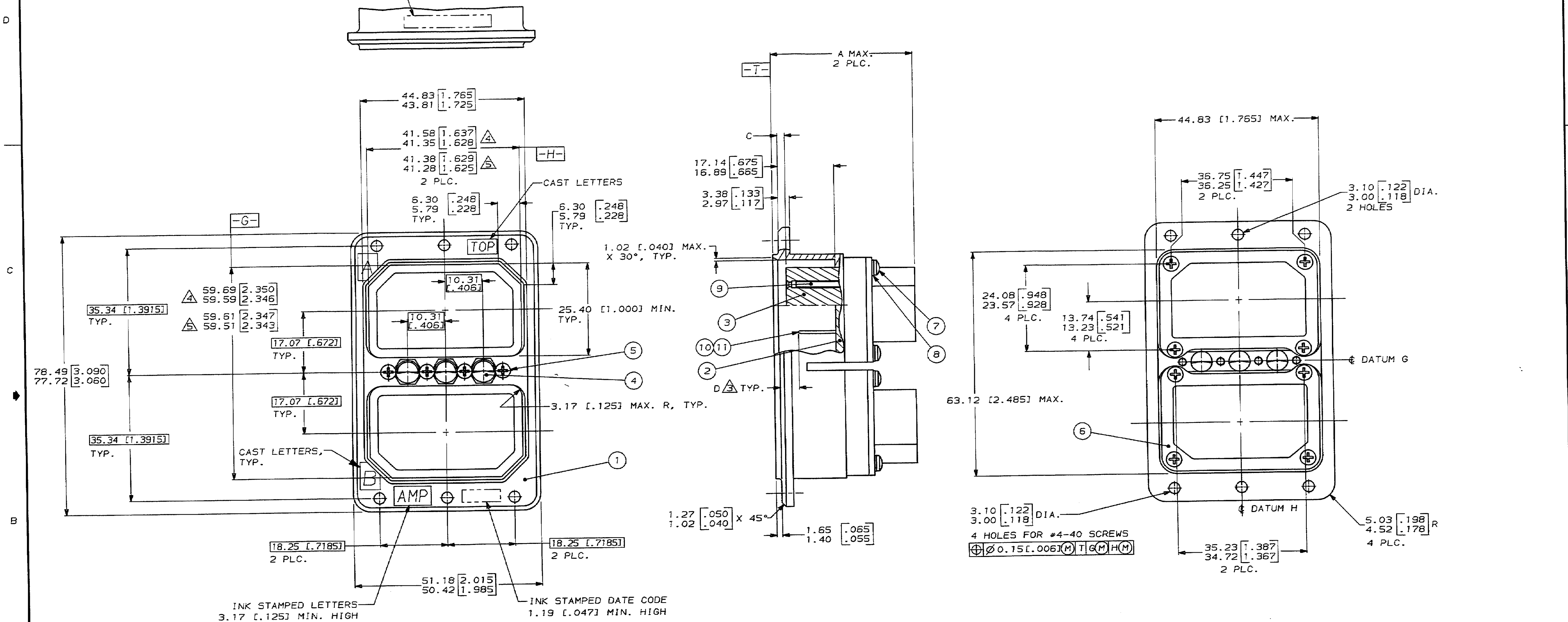

- CONTACTS SHOWN LOADED FOR ILLUSTRATION ONLY; ARE INCLUDED IN A CONTAINER WITHIN CONNECTOR PACKAGE FOR SHIPMENT.
- FOR INSERT ARRANGEMENTS AND DIMENSIONS, SEE TABLES ON SHEET 2 OF 2.
- FOR CONTACT SIZE 22, D DIMENSION REPRESENTS SOCKET CONTACTS.
- DIMENSION TAKEN AT 7.67/7.57 [.302/.298] FROM TOP EDGE.
- DIMENSION TAKEN AT 1.32/1.22 [.052/.048] FROM BOTTOM OF CAVITY.
- DIMENSIONS IN BRACKETS ARE IN INCHES.

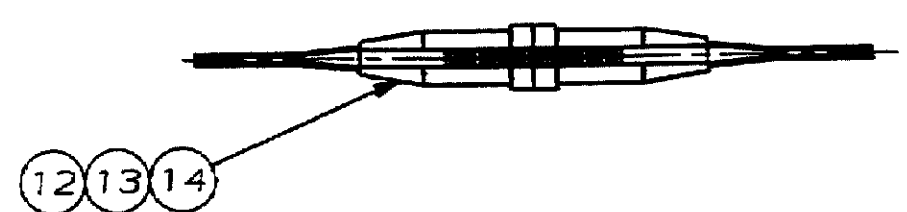

UNLESS OTHERWISE SPECIFIED DIMENSIONS ARE IN MM TOLERANCES ON:		DR 3-11-87 MARK HOFFECKER		PART NO.	
2 PL DEC ±		CHK 3-11-87 LARRY LAWNER	AMP INCORPORATED Harrisburg, Pa. 17105		
3 PL DEC ±		APPD 3-11-87 EDWARD HOWARD	NAME		
ANGLES ±	0°30'	APPD 3-11-87 E. SMITH	RECEPTACLE CONN. KIT, ARINC 404, DUAL INSERT, R2R SERIES		
MATERIAL	SEE TABLE SHT. 2 OF 2	PRODUCT SPEC	SIZE	FSCM NO	DRAWING NO
FINISH	SEE TABLE SHT. 2 OF 2	APPLICATION SPEC	D	00779	213434
		WEIGHT	SCALE	2:1	SHEET 1 OF 2

**METRIC**

CUSTOMER DRAWING

