

IPSUAT Series

Intrinsically Safe Pressure Transducer



Approvals:-
ATEX / IECEx
II 1G Ex ia IIC T4 Ga (Ta -see schedule)



- Piezo-resistive thick film ceramic sensor
- Stainless steel body
- Accuracy $\leq \pm 0.25\%$ FS BFSL
- Pressure ranges from vacuum to 5800psi

The IPSUAT series is ideally suited for use in a wide range of industrial applications in hazardous areas. The probe uses a piezo-resistive ceramic sensor, giving excellent media compatibility within a stainless steel housing

The electronics incorporate a microprocessor based amplifier, requiring no adjusting and giving stable electronics, especially industrial applications.

Each device is temperature compensated, calibrated and supplied with a traceable serial number and calibration data.



Electrical Protection

Supply reverse polarity	No damage but also no function
Electromagnetic compatibility	CE Compliant

Mechanical Stability

Shock	100g / 11s
Vibration	10g RMS (20 - 2000Hz)

Environment & Thermal Effects

Ambient Temperature Range	-20°C to +75°C
Storage temperature	-40°C to +80°C
Compensated temperature range	+20°C to +80°C
Thermal Zero Shift (TZS)	$\leq \pm 0.04\%$ /FS/°C
Thermal Span Shift	$\leq \pm 0.015\%$ /°C
Permissible environment	Zone 0

Performance

Accuracy (Non-Linearity & Hysteresis)	$\leq \pm 0.25\%$ / FS (BFSL)
Setting Errors (offsets)	Zero & Full Scale, $\leq \pm 0.5\%$ / FS

Material Specifications

Housing	316 Stainless Steel
"O" ring seals	Viton
Diaphragm	Ceramic Al ₂ O ₃ 96%
Media wetted parts	Housing & connection, "O" ring seal, diaphragm
Weight	Approx 100g
Installation position	Any
Operational Life	> 100x 10 ⁶ cycles
Insulation resistance	> 50MΩ at 50Vdc

Pressure Ranges

Nominal Pressure, Gauge, psi	15	30	75	150	300	750	1500	3750	6000
Compound range psi	-15 to 0	-15 to 30	-15 to 75	-15 to 1235	-15 to 285	-15 to 360			
Permissible Overpressure psi	30	60	150	300	600	1500	3000	6000	9750
Burst Pressure psi	60	75	180	375	750	1800	3750	7500	9750

Output Signal and Supply Voltage

Wire system	Output	Supply Voltage	Connection	Pin Nos
2-wire	4-20mA	10-28Vdc	+ve Supply	Pin 1 -ve Supply Pin 2 Ground Earth Pin

Cynergy3 Components Ltd.
7 Cobham Road
Ferndown Industrial Estate
Wimborne, Dorset BH21 7PE
Telephone +44 (0) 1202 897969
Email:sales@cynergy3.com



Made in the UK

ISO9001 CERTIFIED
IPSUAT 2017

www.cynergy3.com

IPSUAT Series

Intrinsically Safe Pressure Transducer



Part Number	Pressure Rating
IPSUAT-GP015-5	0-15psi G
IPSUAT-GP030-5	0-30psi G
IPSUAT-GP075-5	0-75psi G
IPSUAT-C0446-5	-14.5 to +150 psi G
IPSUAT-GP100-5	0-100psi G
IPSUAT-GP150-5	0-150psi G
IPSUAT-C0447-5	-14.5 to +350 psi G
IPSUAT-GP300-5	0-300psi G
IPSUAT-GP750-5	0-750psi G
IPSUAT-GP1K5-5	0-1500psi G
IPSUAT-GP3K6-5	0-3600psi G
IPSUAT-GP5K8-5	0-5800psi G

Mechanical Dimensions

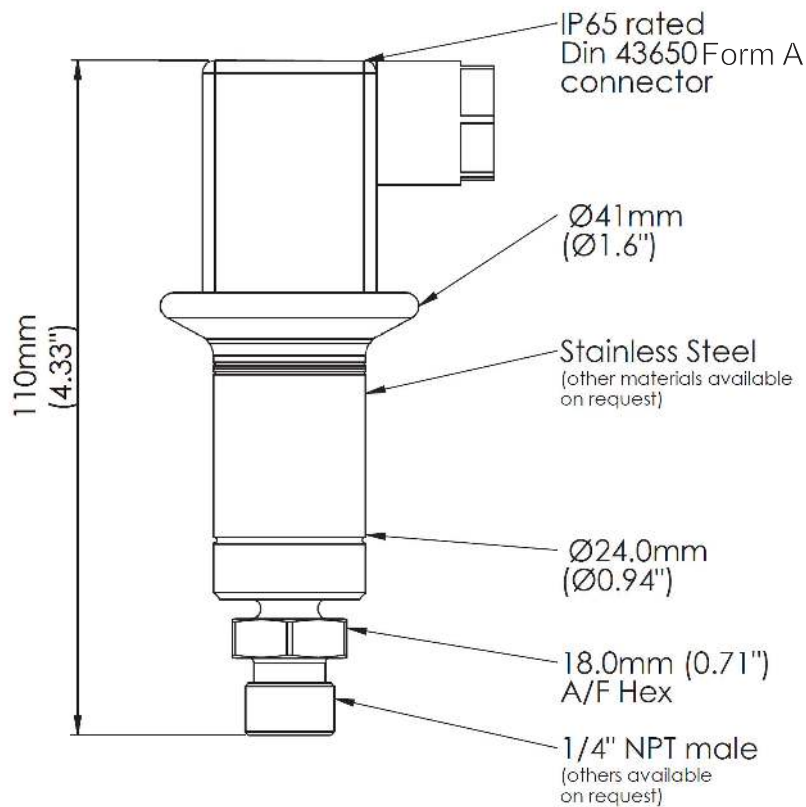

Cynergy3 Components Ltd.
7 Cobham Road
Ferndown Industrial Estate
Wimborne, Dorset BH21 7PE
Telephone +44 (0) 1202 897969
Email:sales@cynergy3.com



Made in the UK

ISO9001 CERTIFIED

www.cynergy3.com