

### GENERAL DESCRIPTION



The M690SDM is a single frequency/single output SAW-based VCSO for low-jitter clock generation. The M690SDM incorporates an analog X2 frequency multiplier to provide an output

frequency that is twice that of the fundamental VCSO frequency.

### FEATURES

- ◆ Integrated SAW device
- ◆ Low phase jitter: 250fs rms typical for the M690SDM (20kHz to 20MHz)
- ◆ Output frequency: 1747 MHz Typ. (Specify center frequency at time of order)
- ◆ Single-ended RF Output
- ◆ Single +5V power supply
- ◆ 13 x 20mm SMT (surface mount) package
- ◆ Pb-free / Compliant to EC RoHS Directive (RoHS 5/6)

### PIN ASSIGNMENT (13 x 20mm SMT)

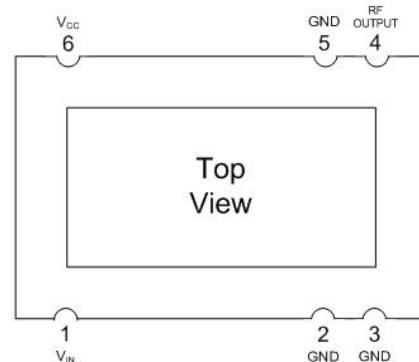

Figure 1: Pin Assignment

### Sample of Available Output Frequencies

VCSO Center Frequencies <sup>1</sup> (MHz)	Output Frequency Code
1747.623000	R01
1747.030837	R02
1748.366885	R03
1748.793733	R04

Table 1: Sample of Available Output Frequencies

Note 1: Specify VCSO center frequency at time of order. Other frequencies available upon request.

### BLOCK DIAGRAM

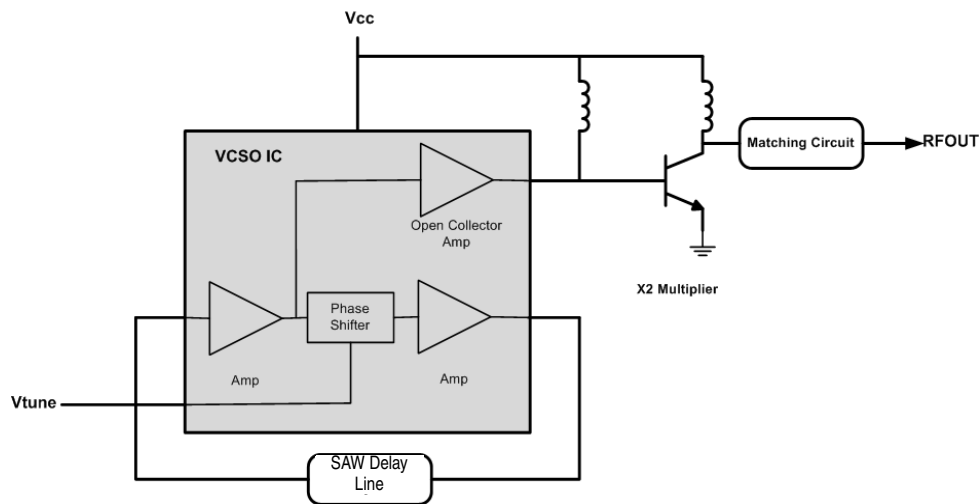

Figure 2: Block Diagram

## PIN DESCRIPTIONS

Number	Name	I/O	Configuration	Description
1	VIN	Input		Frequency control input.
2, 3, 5	GND	Ground		Power supply ground connection.
4	RF OUTPUT	Output	No internal terminator	Clock output. Single-ended.
6	VCC	Power		Power supply connection, connect to +5.0 V.

Table 2: Pin Descriptions

## ABSOLUTE MAXIMUM RATINGS<sup>1</sup>

Symbol	Parameter	Rating	Unit
$V_I$	Inputs	-0.5 to $V_{CC} + 0.5$	V
$V_O$	Outputs	-0.5 to $V_{CC} + 0.5$	V
$V_{CC}$	Power Supply Voltage	6.0	V
$T_S$	Storage Temperature	-55 to +125	°C

Table 3: Absolute Maximum Ratings

Note 1: Stresses beyond those listed under Absolute Maximum Ratings may cause permanent damage to the device. These ratings are stress specifications only. Functional operation of product at these conditions or any conditions beyond those listed in Recommended Conditions of Operation, DC Characteristics, or AC Characteristics is not implied. Exposure to absolute maximum rating conditions for extended periods may affect product reliability.

## RECOMMENDED CONDITIONS OF OPERATION

Symbol	Parameter	Min	Typ	Max	Unit
$V_{CC}$	Positive Supply Voltage	4.875	5.0	5.125	V
$T_{CASE}$	Operating Temperature	+10		+85	°C

Table 4: Recommended Conditions of Operation

## ELECTRICAL SPECIFICATIONS

### DC Characteristics for M690SDM

Unless stated otherwise,  $V_{CC} = 5.0 \text{ Volts} \pm 2.5\%$ ,  $T_{CASE} = 10 \text{ to } 85^\circ\text{C}$ , VCISO Frequency = 1747.623000, Output terminated with 50Ω

	Symbol	Parameter	Pin	Min	Typ	Max	Unit
Power Supply	$V_{CC}$	Positive Supply Voltage	VCC	4.875	5.0	5.125	V
	$I_{CC}$	Power Supply Current				145	165
Control Voltage	$V_{IN}$	Input Control Voltage Range	VIN	0		3.3	V
		$V_{IN}$ Input Impedence			20		

Table 5: DC Characteristics for M690SDM

### AC Characteristics for M690SDM

Unless stated otherwise,  $V_{CC} = 5.0 \text{ Volts} \pm 2.5\%$ ,  $T_{CASE} = 10 \text{ to } 85^\circ\text{C}$ , VCISO Frequency = 1747.623000, Outputs terminated with 50Ω

	Symbol	Parameter	Pin	Min	Typ	Max	Unit	Notes
Control Voltage	$V_{IN}$	Modulation Bandwidth	VIN		500		kHz	
Output	RF OUTPUT	Output Center Frequency Range		1500		2100	MHz	
	$P_{OUTPUT}$	Output Power		7.5	10.0	12.0	dBm	50Ω load; AC Coupled
	$T_{RANGE}$	Tuning Range			1000		ppm	
	APR	Absolute (Guaranteed) Pull-Range <sup>1</sup>		±100			ppm	
	$f_{STAB}$	Frequency Stability			300		ppm p-p	10°C to 85°C
		Power Supply Pushing		-32		32	ppm	$V_{CC} = 5.0V \pm 2.5V$
	$L_{IN}$	Tuning Linearity		-8		8	%	Deviation from best Linear fit
	$K_{VCO}$	VCO Gain	@ 1747.623000MHz		340		ppm/V	
		Harmonic Spurious				-30	dBc	
		Sub-harmonic Spurious				-30	dBc	
		Non-harmonic Spurious				-60	dBc	
	VSWR	Load VSWR, all phases				3.5:1		
	$\Phi_n$	SSB (single sideband) Phase Noise, offset from carrier @ 1747.623000MHz	10kHz Offset		-95			dBc/Hz
		100kHz Offset		-116			dBc/Hz	
		1MHz Offset		-134			dBc/Hz	
		10MHz Offset		-140			dBc/Hz	
		20MHz Offset		-143			dBc/Hz	

Table 6: AC Characteristics for M690SDM

Note 1: Also fully meets ±50 ppm minimum pull-range.

**DEVICE PACKAGE - 13 x 20mm SMT (Surface Mount) Package**

Mechanical Dimensions:

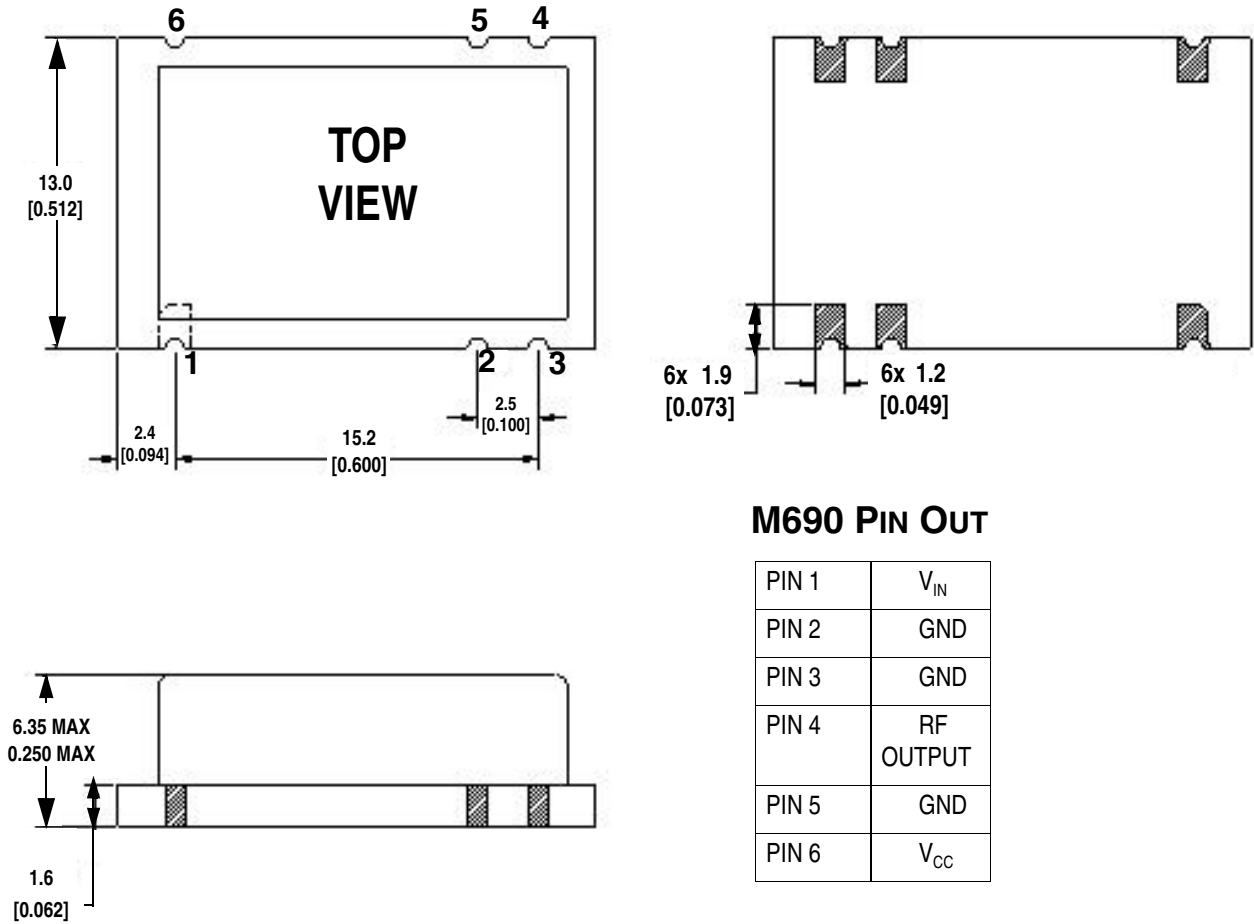

Pad Finish: Gold over Nickel  
 MSL 1

Figure 3: Device Package - 13 x 20mm SMT (Surface Mount Package)

## ORDERING INFORMATION

### Part Numbering Scheme

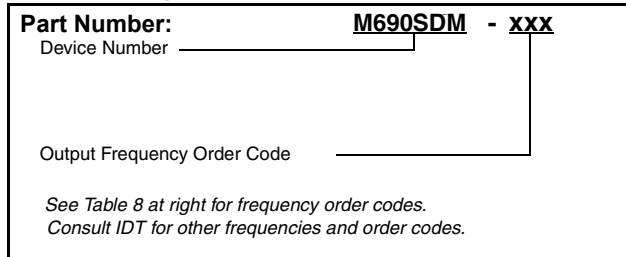

*Figure 4: Part Numbering Scheme*

### M690SDM Standard Output Frequencies & Order Codes

Output Frequency Code	Output Frequency MHz
R01	1747.623000
R02	1747.030837
R03	1748.366885
R04	1748.793733

**Table 8: M690SDM Standard Output Frequencies & Order**

### Example Order Numbers

For Output Frequencies (MHz) <i>Frequency</i>	Order Part Number M690SDM-xxx
1747.623000	<b>M690SDM-R01</b>
1747.030837	<b>M690SDM-R02</b>

**Table 7: Example Order Numbers**

*Consult IDT for the availability of other frequencies*