

Description

The ISL54205BEVAL1Z evaluation board is designed to provide a quick and easy method for evaluating the ISL54205B USB/Audio Switch IC.

The ISL54205B device is a unique IC. To use this evaluation board properly requires a thorough knowledge of the operation of the IC. Refer to the ISL54205B data sheet for an understanding of the functions and features of the device. Studying the device's truth table along with its pinout diagram on page 2 of the ISL54205B data sheet is the best way to get a quick understanding of how the part works.

A picture of the main evaluation board is shown in Figure 1. The ISL54205B μ TQFN IC is soldered onto the evaluation board. It is located in the center of the board and is designated as U1.

The ISL54205B IC has two modes of operation called Audio mode and USB mode. The evaluation board contains standard Audio and USB connectors to allow the user to easily interface with the IC to evaluate its functions, features, and performance in the two modes of operation. For example, when the board is properly powered, a headphone can be plugged into the headphone jack (J7) and a stereo source, such as an MP3 player, can be connected at the RCA connectors J3 (AUDIO LEFT) and J4 (AUDIO RIGHT) to play music through the audio switches of the IC (see Figure 2). You can then turn-off the audio source, remove the headphones, and attach a USB cable from a computer to the USB connector J1 (USB TO HOST). This will establish a connection from the computer through the USB switches of the IC to the USB device connected at the USB connector J2 (USB TO DEVICE), to send and receive data.

This application note will guide the user through the process of configuring and using the evaluation board to evaluate the ISL54205B device in both the Audio mode and the USB mode.

Features

- Standard USB Connectors
- RCA Audio Input Jacks and Headphone Speaker Jack
- Convenient Test Points and Connections for Test Equipment

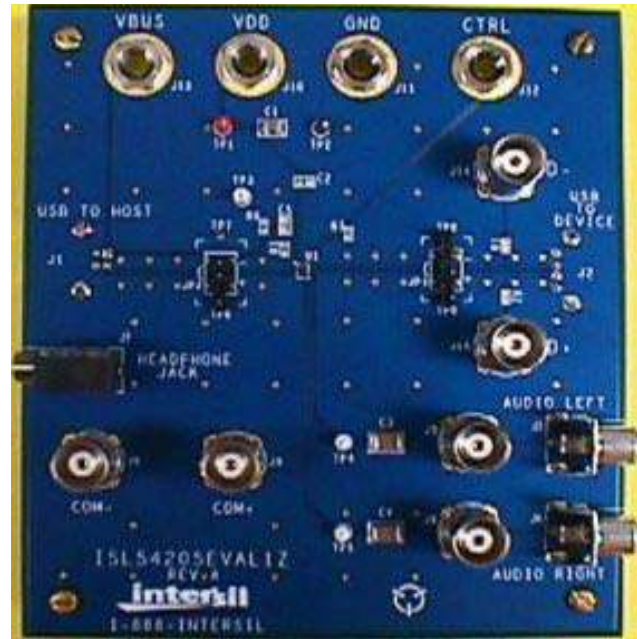

FIGURE 1. ISL54205BEVAL1Z EVALUATION BOARD (TOP VIEW)

Board Architecture/Layout

Basic Layout of Evaluation Board

The basic layout of the main board is as follows: Refer to Figure 1.

Power and Ground connections are at the top of the board (J10 and J11).

Audio Source Inputs are at the lower right side of the board (J3, J4, J5 and J6). Audio outputs are at the lower left side of the board (J7, J8, J9). Connector J7 is a standard headphone jack for connecting a 32 Ω headphone.

USB connection to an upstream host controller (Computer) is made at connector J1, located on left underside of the board. USB connection to a downstream USB device is made at connector J2, located on right underside of the board.

Located in the center of the board is the ISL54205B IC (U1). The evaluation board has a pin 1 dot, to show how the IC should be oriented on to the evaluation board. The IC pin 1 indicator dot needs to be aligned with the evaluation board pin 1 dot indicator.

Power Supply

The DC power supply connected at banana jacks J10 (VDD) and J11 (GND) provides power to the part. The IC requires a 2.7V to 3.6V DC power supply for proper operation. The power supply should be capable of delivering 100 μ A of current.

Logic Control

The state of the ISL54205B device is determined by the voltage at the VBUS pin and the CTRL pin. Access to the CTRL pin is through the banana jack J12 (CTRL) and access to the VBUS pin is through the USB J1 connector or the banana jack J13 (VBUS).

If VBUS is floating (no USB host controller connected at the J1 connector) and CTRL = High (J12 connected to J10), the part will be in the Audio mode.

If VBUS is floating (no USB host controller connected at the J1 connector) and CTRL = Low or Floating, the part will be in the Low Power mode. In Low Power mode all switches are OPEN and the part will draw around 1nA of current.

If VBUS is greater than VDD by 0.8V (USB computer VBUS line connected at the J1 USB connector), the part will be in the USB mode. In a typical application, the VBUS voltage from computer/host controller will be in the range of 4.4V to 5.25V and the VDD voltage to the ISL54205B part will be in the range of 2.7V to 3.6V.

Audio Inputs

The evaluation board has two audio inputs labeled AUDIO LEFT (J3 or J5) and AUDIO RIGHT (J4 or J6). Each of these inputs have a BNC connector wired in parallel with a RCA jack connector. You can connect an audio source/generator at either the BNC connector or the RCA connector.

In a typical application, the left and right outputs of a stereo source (such as an MP3 player) would be connected to the RCA jacks J3 and J4, respectively.

Over a signal range of $\pm 1V$ ($0.707V_{RMS}$) the audio switches have an extremely low r_{ON} resistance variation. They can pass ground referenced audio signals with very low distortion ($<0.05\%$ THD+N) when delivering 15.6mW into a 32Ω headphone speaker load. A $3V_{P-P}$ signal is acceptable but performance will degrade.

The audio channels are AC-coupled with $100\mu F$ capacitors. These capacitors remove any DC voltage from the audio signals and reference them to ground of the device. If the audio source being connected to the evaluation board already has internal AC coupling capacitors at the output of its drivers, then the capacitors on the evaluation board should be shorted out (replaced with 0Ω resistors). This will prevent further attenuation of the low frequency content of the audio signal due to the increase of the high-pass corner frequency resulting from the evaluation board capacitor in series with the audio source capacitor.

The audio switches are not bi-directional. The audio source needs to be connected at J3 or J5 and J4 or J6. Do not try to apply an audio source at the J8 and J9 BNC connectors on the left side of the board and loads at J3 through J6 on the right side of the board.

Note: When in USB mode, the audio source needs to be in a high impedance state so it will not interfere with the USB signal. Since the audio source inputs are AC-coupled on the evaluation board, simply turning the audio source OFF will isolate it from interfering with the USB signal.

Audio Outputs

The evaluation board has a standard headphone jack labeled HEADPHONE JACK (J7). A 32Ω stereo headphone should be plugged into this jack.

The BNC connector J8 (COM-) is in parallel with the audio left line of the headphone jack and the D- line of the J1 (USB To HOST) connector. The BNC connector J9 (COM+) is in parallel with the audio right line of the headphone jack and the D+ line of the J1 (USB To DEVICE) connector. These BNC connectors can be used to connect resistive loads and/or test equipment to evaluate the performance of the IC.

USB Connections

A "B" type USB receptacle labeled USB TO HOST (J1) is located on the left underside of the board. This receptacle should be connected using a standard USB cable to the upstream USB host controller, which is usually a PC computer or hub. When this connection is made, the ISL54205B device will sense the VBUS voltage from the host controller and go into USB mode. The USB switches will be turned ON.

An "A" type USB receptacle labeled USB TO DEVICE (J2) is located on the right underside of the board. The USB device can be plugged directly into this receptacle or through a standard USB cable.

In USB mode the USB host controller and USB device will be connected through the internal USB switches of the IC. Unlike the audio switches, the USB switches are bi-directional, which allow the host (computer) and downstream USB device to both send and receive data.

Note: Before connecting the USB host controller at connector J1, the headphones must be removed from the headphone speaker jack, J7. This will prevent the audio load from interfering with USB signal transmission. The main purpose of the ISL54205B device is to allow the use of a common USB and Audio Headphone Connector in Personal Media Players and other portable battery powered equipment. Either a headphone will be in the common connector to play music or a USB cable from a computer will be in the common connector to transmit digital data, such as music, into the memory of the Media Player.

The BNC connector J8 (COM-) is in parallel with the D- line of the J1 USB connector. The BNC connector J9 (COM+) is in parallel with the D+ line of the J1 USB connector. The BNC connector J13 (VBUS) is in parallel with the VBUS line of the J1 USB connector.

The BNC connector J14 (D-) is in parallel with the D- line of the J2 USB connector. The BNC connector J15 (D+) is in parallel with the D+ line of the J2 USB connector. If you want to use the J14 and J15 BNC connectors, you must populate R₁ and R₂ with 0Ω resistors. These BNC connectors can be used to connect test equipment to evaluate the performance of the IC.

Board Component Definitions

DESIGNATOR	DESCRIPTION
U1	ISL54205BIRUZ IC
J1	"B" type USB Receptacle
J2	"A" type USB Receptacle
J3, J5	Left Stereo Audio Input
J4, J6	Right Stereo Audio Input
J7	Headphone Speaker Jack
J8	COM- BNC Connector
J9	COM+ BNC Connector
J10	VDD Positive Connection
J11	VDD Negative Connection
J12	CTRL Logic Control
J13	VBUS Logic Control (In parallel with J1 USB V _{BUS} line. Control will typically be through J1 connector)
J14	D- BNC Connector
J15	D+ BNC Connector
JP1, JP2	D-/D+ Differential Probe Connection

Using the Board (Refer to Figure 2)

Lab Equipment

The equipment, external supplies and signal sources needed to operate the evaluation board are listed below:

1. +2.7V to 3.6V DC Power Supply
2. Stereo Audio Source (MP3/Radio/CD Player) or Audio Generator
3. Headphone Set or Audio Analyzer/Oscilloscope
4. Two standard USB cables
5. Computer with USB port
6. USB device (i.e. USB memory stick, MP3 Player with USB port, etc.)

Initial Board Setup Procedure

1. Attach the main evaluation board to a DC power supply at J10 (VDD) and J11 (GND); positive terminal at J10 and negative terminal at J11. The supply should be capable of delivering 2.7V to 3.6V and 100μA of current. Set the supply voltage to 3.3V.
2. Connect the stereo audio source left channel to J3 RCA connector or J5 BNC connector, and the right channel to J4 RCA connector or J6 BNC connector.
3. Connect the USB device to the USB "B" type receptacle, J2 (USB TO DEVICE).

Audio Mode Operation

1. Install headphone in the headphone jack, J7. No USB cable should be connected at the J1 (USB TO HOST) connector.
2. Connect J12 (CTRL) to J10 (VDD). You will now be in Audio mode (3Ω audio switches are ON).
3. Turn the audio source ON. You should hear the music in the headphones.

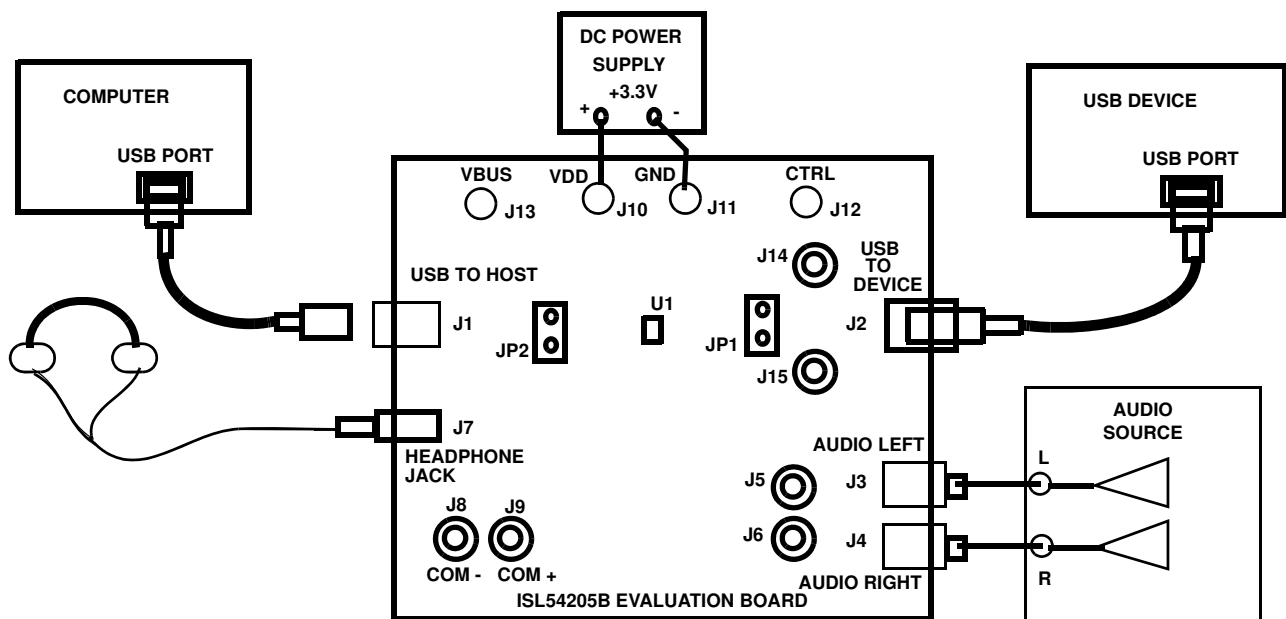

FIGURE 2. BASIC EVALUATION TEST SETUP BLOCK DIAGRAM

Application Note 1483

- You can observe the audio signals at the output of the IC on an oscilloscope or audio analyzer by using the J8 and J9 BNC connectors. Connect to J8 for left audio and J9 for right audio.

USB Mode Operation

- Turn OFF audio stereo source.
- Remove headphone from J7 Headphone Jack.
- Connect USB cable from host (PC computer) to the USB "A" type receptacle, J1 (USB TO HOST). You will now be in USB mode (5.5Ω USB switches are ON).
- You should now be able to send and receive data between the host and USB device.
- You can observe the D- and D+ USB digital signals on an oscilloscope or other test equipment by connecting to the J8, J14, J9 and J15 BNC connectors. Connect to J8/J14 for D- signal and to J9/J15 for D+ signal. The V_{BUS} voltage from the host can be monitored by connecting a voltmeter at the J13 BNC connector.
- Remove the 0Ω resistors R₁, R₂, R₃, R₄ when evaluating the performance (i.e. eye diagram, etc.) of the high speed USB signal. Removal of these resistors disconnects the headphone jack (J7) and BNC connectors (J8, J9, J14, J15) from the USB differential lines. These components when connected will degrade the USB signal and will not

be there in an actual application. Note: R₃ and R₄ are located on the underside of the board.

If you disconnect the USB cable from J1, the IC will return to Audio mode. You can now plug the headphone set into the headphone jack. Turn the audio source ON to once again play music.

Test Points

The board has various test points for ease of connecting probes to make measurements. The test points available are described in Table 1.

TABLE 1.

DESIGNATOR	DESCRIPTION
TP1	V _{DD} test point
TP2, TP6, TP7, TP8, TP9	Ground Test Point
TP3	V _{BUS} Test Point
TP4	Audio Left Input Test Point
TP5	Audio Right Input Test Point
JP1	D-/D+ Differential Probe Connection - USB Device Side of Switch

ISL54205BEVAL1Z Board Schematic

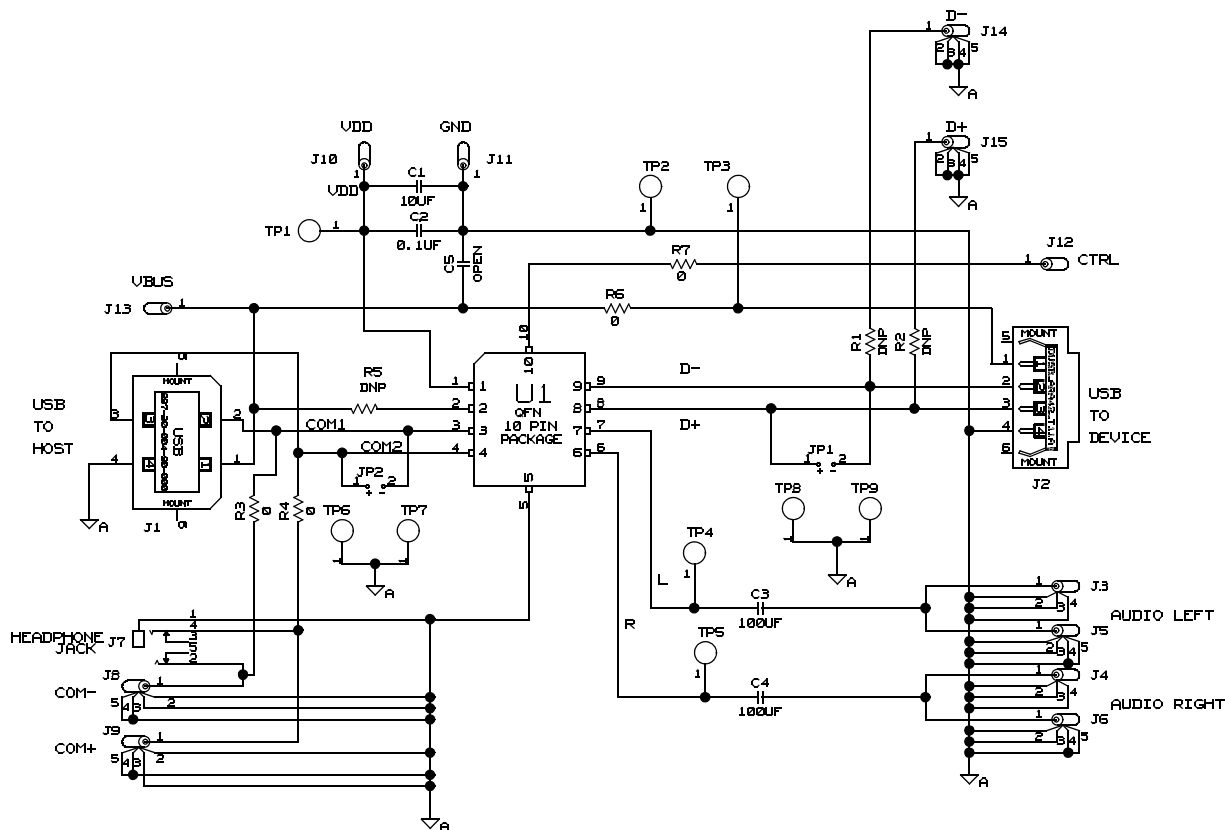

Intersil Corporation reserves the right to make changes in circuit design, software and/or specifications at any time without notice. Accordingly, the reader is cautioned to verify that the Application Note or Technical Brief is current before proceeding.

For information regarding Intersil Corporation and its products, see www.intersil.com