

PSI-TERMINATOR-PB



Active termination resistor for PROFIBUS and RS-485 networks

Data sheet
104411_en_05

© PHOENIX CONTACT 2016-06-21

1 Description

PROFIBUS and other RS-485 2-wire networks can be actively terminated at the bus end using the **PSI-TERMINATOR-PB**. This ensures safe communication even if the bus device is connected/disconnected during operation.

In addition, the device can be operated as an electrically isolated service interface. The alternative D-SUB connection is used as a power supply for an active programming device.

The bus connection takes place via a plug-in double connection terminal block or alternatively via a D-SUB socket.

Separate LED displays are available to the user for voltage supply and bus activity diagnostics.

An extended temperature range of -20 °C to 65 °C and a compact housing with a width of 22.5 mm allows use under industrial environmental conditions and in confined spaces.

Features

- PROFIBUS up to 12 Mbps
- electrical isolation of supply and data interface
- switchable termination
- 24 V DC supply voltage
- Programming interface for active and passive programming devices
- 22.5 mm wide, 54 mm high
- large temperature range of -20 °C to +65 °C
- Diagnostics LEDs for VCC and data activity
- Mounted on EN DIN rails
- two shield clips supplied as standard



WARNING: Explosion hazard when used in potentially explosive areas

The device is a category 3 item of electrical equipment. Follow the instructions provided here during installation and observe the safety notes.



Make sure you always use the latest documentation.
It can be downloaded from the product at phoenixcontact.net/products.

2	Table of contents	
1	Description	1
2	Table of contents	2
3	Ordering data	3
4	Technical data	4
5	UL notes	7
6	Safety regulations and installation notes.....	8
	6.1 Installation in Zone 2.....	8
7	Function.....	9
8	Basic circuit diagram	10
9	Dimensional drawing	10
10	Install shield clip	11
11	Install signal cable	11
12	Deinstall signal cable	12
13	Supply voltage	12
14	Application examples	13

3 Ordering data

Description	Type	Order No.	Pcs./Pkt.
Active termination resistor for PROFIBUS and RS-485 bus systems. Compact design, electrical isolation between supply and data interface, bus termination can be activated, integrated programming interface.	PSI-TERMINATOR-PB	2313944	1
Accessories			
D-SUB connector, 9-pos., male connector, cable entry < 90°, bus system: PROFIBUS DP up to 12 Mbps, termination resistor can be switched on via slide switch, pin assignment: 3, 5, 6, 8; IDC terminal block connection	SUBCON-PLUS-PROFIB/90/IDC	2313672	1
D-SUB connector, 9-pos., male connector, cable entry < 90°, bus system: PROFIBUS DP up to 12 Mbps with PG D-SUB socket for connecting a programming device, termination resistor can be switched on via slide switch, pin assignment: 3, 5, 6, 8; IDC terminal block connection	SUBCON-PLUS-PROFIB/90/PG/IDC	2313685	1
D-SUB connector, 9-pos., male connector, cable entry < 90°, bus system: PROFIBUS DP up to 12 Mbps, termination resistor can be switched on via slide switch, pin assignment: 3, 5, 6, 8; screw connection terminal blocks	SUBCON-PLUS-PROFIB/90/SC	2313698	1
D-SUB connector, 9-pos., male connector, cable entry < 90°, bus system: PROFIBUS DP up to 12 Mbps with PG D-SUB socket for connecting a programming device, termination resistor can be switched on via slide switch, pin assignment: 3, 5, 6, 8; screw connection terminal blocks	SUBCON-PLUS-PROFIB/90/PG/SC	2313708	1
D-SUB plug, 9-pos., pin, assignment: 3, 5, 6, 8; two M12 cable glands (B-coded) under 35°. Bus system: PROFIBUS DP up to 12 Mbps. Termination resistor via separate M12 terminator.	SUBCON-PLUS-PROFIB/35/M12	2902320	1
D-SUB plug, 9-pos., pin, assignment: 3, 5, 6, 8; two M12 cable glands (B-coded) under 90°. Bus system: PROFIBUS DP up to 12 Mbps. Termination resistor via separate M12 terminator.	SUBCON-PLUS-PROFIB/90/M12	2902318	1
D-SUB plug, 9-pos., pin, assignment: 3, 5, 6, 8; two M12 cable glands (B-coded) under 90°. Bus system: PROFIBUS DP up to 12 Mbps. Termination resistor via separate M12 terminator. Long version; S7-compatible.	SUBCON-PLUS-PROFIB/90X/M12	2902729	1
PROFIBUS cable, Fast Connect type, up to 12 Mbps (02YSY (ST)CY 1x2x22 AWG) By the meter, Bus system cable, PROFIBUS (12 Mbps), shielded, PVC FR VI/PVC, Violet, 2-wire (1X2XAWG22/1), Color, single wire: Red, green, Cable length: Free entry (1.0 ... 1000.0 m)	PSM-CABLE-PROFIB/FC	2744652	1
Actuation tool, for ST terminal blocks, also suitable for use as a bladed screwdriver, size: 0.4 x 2.5 x 75 mm, 2-component grip, with non-slip grip	SZF 0-0,4X2,5	1204504	10

Accessories	Type	Order No.	Pcs./Pkt.
Quick stripping tool for PROFIBUS cable, type Fast Connect	PSM-STRIP-FC/PROFIB	2744623	1
Stripping tool for cables with PVC insulation, stripping range: 0.08 to 6 mm ² , wire cutting up to 6 mm ² flexible or 4 mm ² rigid	QUICK WIREFOX 6	1204384	1
D-SUB connector, 9-pos., male connector, cable entry < 35°, bus system: PROFIBUS DP up to 12 Mbps, termination resistor can be switched on via slide switch, pin assignment: 3, 5, 6, 8; screw connection terminal blocks	SUBCON-PLUS-PROFIB/SC2	2708232	1
D-SUB connector, 9-pos., male connector, cable entry < 35°, bus system: PROFIBUS DP up to 12 Mbps with PG D-SUB socket for connecting a programming device, termination resistor can be switched on via slide switch, pin assignment: 3, 5, 6, 8; screw connection terminal blocks	SUBCON-PLUS-PROFIB/PG/SC2	2708245	1
D-SUB connector, 9-pos., male connector, axial version with two cable entries, bus system: PROFIBUS DP up to 12 Mbps, termination resistor can be switched on via slide switch, pin assignment: 3, 5, 6, 8; screw connection terminal blocks	SUBCON-PLUS-PROFIB/AX/SC	2744380	1
Modular repeater for electrical isolation and range increase for PROFIBUS up to 12 Mbps, 4-way isolation, rail-mountable, supply 24 V DC	PSI-REP-PROFIBUS/12MB	2708863	1
Modular repeater for electrical isolation and range increase in RS-485 2-wire bus systems up to 500 kbps, 4-way isolation, rail-mountable, supply 24 V DC	PSI-REP-RS485W2	2313096	1
Repeater, for potential separation and range increase in RS-485 2-wire bus systems, 3-way isolation, rail-mountable	PSM-ME-RS485/RS485-P	2744429	1
Interface converter, for converting RS-232 (V.24) to RS-422 (V.11) and RS-485, with electrical isolation, 2 channels, rail-mountable	PSM-ME-RS232/RS485-P	2744416	1

4 Technical data

Supply	
Supply voltage range	19.2 V DC ... 28.8 V DC (via pluggable COMBICON screw terminal block)
Nominal supply voltage	24 V DC (via pluggable COMBICON screw terminal block)
Typical current consumption	45 mA (24 V DC)
Electrical isolation	DIN EN 50178 (RS-485 // VCC)
Test voltage data interface/power supply	1.5 kV _{rms} (50 Hz, 1 min.)
Torque	0.56 Nm ... 0.79 Nm

PROFIBUS acc. to IEC 61158, RS-485 2-conductor

Connection method	D-SUB 9, COMBICON
Output nominal voltage	5 V DC
Conductor cross section	0.2 mm ² ... 1.5 mm ² (24 AWG ... 16 AWG)
Strain relief	Shield clip in spring-cage terminal block
Termination resistor	390 Ω / 220 Ω / 390 Ω
Serial transmission speed	≤ 12 Mbps
Transmission length	≤ 1200 m (Depends on transmission speed and cable type)
Status and diagnostic indicators	LEDs: UL (communications power), data activity (not marked)

General data

Degree of protection	IP20
Dimensions (W/H/D)	22.5 mm x 99 mm x 56 mm
Housing material	PA 6.6-FR green
Free fall in acc. with IEC 60068-2-32	1 m
Vibration resistance in acc. with EN 60068-2-6/ IEC 60068-2-6	5g, 10-150 Hz, 2.5 h, in XYZ direction
Shock in acc. with EN 60068-2-27/IEC 60068-2-27	25g, 11 ms period, half-sine shock pulse
MTTF (mean time to failure) SN 29500 standard, temperature 25°C, operating cycle 21 % (5 days a week, 8 hours a day)	3550 Years
MTTF (mean time to failure) SN 29500 standard, temperature 40°C, operating cycle 34.25 % (5 days a week, 12 hours a day)	1818 Years
MTTF (mean time to failure) SN 29500 standard, temperature 40°C, operating cycle 100 % (7 days a week, 24 hours a day)	849 Years
Electromagnetic compatibility	Conformance with EMC Directive 2014/30/EU

Ambient conditions

Ambient temperature (operation)	-20 °C ... 65 °C
Ambient temperature (storage/transport)	-40 °C ... 85 °C
Permissible humidity (operation)	30 % ... 95 % (non-condensing)
Altitude	5000 m (For restrictions see manufacturer's declaration)

Approvals / Certificates

Conformance	CE-compliant EAC
Free from substances that could impair the application of coating	according to P-VW 3.10.7 57 65 0 VW-AUDI-Seat central standard
ATEX, Please follow the special installation instructions in the documentation!	Ⓜ II 3 G Ex nA IIC T4 Gc X
UL, USA/Canada	508 listed Class I, Div. 2, Groups A, B, C, D
UL, USA	Class I, Zone 2, AEx nA IIC T5
UL, Canada	Class I, zone 2, Ex nA IIC T5 Gc X

Conformance with EMC Directive 2014/30/EU

Noise immunity according to EN 61000-6-2

Electrostatic discharge	EN 61000-4-2	
	Contact discharge	± 6 kV (Test Level 3)
	Discharge in air	± 8 kV (Test Level 3)
	Comments	Criterion B
Electromagnetic HF field	EN 61000-4-3	
	Frequency range	80 MHz ... 3 GHz (Test Level 3)
	Field intensity	10 V/m
	Comments	Criterion A
Fast transients (burst)	EN 61000-4-4	
	Input	± 2.2 kV (Test Level 3)
	Signal	± 2.2 kV (Test Level 3)
	Comments	Criterion B
Surge current loads (surge)	EN 61000-4-5	
	Input	± 0.5 kV (DC supply)
	Signal	± 1 kV (Data line, asymmetrical)
	Comments	Criterion B
Conducted interference	EN 61000-4-6	
	Frequency range	0.15 MHz ... 80 MHz
	Voltage	10 V
	Comments	Criterion A

Emitted interference in acc. with EN 61000-6-4

Radio interference voltage in acc. with EN 55011	EN 55011 class A industrial area of application
Emitted radio interference in acc. with EN 55011	EN 55011 class A industrial area of application
Interference emission	EN 61000-6-4

- Criterion A Normal operating behavior within the specified limits
- Criterion B Temporary impairment of operating behavior that is corrected by the device itself

5 UL notes

⑩ INDUSTRIAL CONTROL EQUIPMENT 11AE

Wire Range: 24-16 AWG

Cu Copper Wire, 60/75C

Torque: 5-7 (Lbs-In)

Environmental designation: "Open Type Device"

Installation Environment: Degree of pollution 2

PROCESS CONTROL EQUIPMENT FOR HAZARDOUS LOCATIONS 31ZN

- A This equipment is suitable for use in Class I, Zone 2, AEx nA IIC T5; Class I, Zone 2, Ex nA IIC T5 Gc X and Class I, Division 2, Groups A, B, C, D or non-hazardous locations only.
- B Conductor temperature rating must be 70°C or higher.
- C Product must be installed in Class I, Zone 2 certified and at least an IP54 enclosure.
- D Product must be used in no more than a degree of pollution 2 environment as defined by IEC 60664-1.
- E Provisions must be made to provide transient protection to the product so that voltage levels do not exceed 40 % of the rated voltage at the power supply terminals.
- F The product has to be installed in an enclosure with tool removable cover or door.

Ambient temperature: -20°C ... +60°C

24 V DC, 45 mA

Wire Range: 30-12 AWG

Torque: 5-7 (Lbs-In)

6 Safety regulations and installation notes



WARNING:

Observe the following safety notes when using the PSI-TERMINATOR-PB!

- The category 3 device is designed for installation in zone 2 potentially explosive areas. It meets the requirements of EN 60079-0:2012+A11:2013 and EN 60079-15:2010.
- Installation, operation, and maintenance may only be carried out by qualified electricians. Follow the installation instructions as described.
- When installing and operating the device, the applicable regulations and safety directives (including national safety directives), as well as general technical regulations, must be observed. The technical data is provided in the package slip and on the certificates (conformity assessment, additional approvals where applicable).
- The device must not be opened or modified. Do not repair the device yourself, replace it with an equivalent device. Repairs may only be carried out by the manufacturer. The manufacturer is not liable for damage resulting from violation.
- The IP20 protection (IEC 60529/EN 60529) of the device is intended for use in a clean and dry environment. The device must not be subject to mechanical strain and/or thermal loads, which exceed the limits described.
- The device is not designed for use in atmospheres with a danger of dust explosions.
- The switch which is accessible on the device may not be operated while the device is connected to the power supply.

6.1 Installation in Zone 2



WARNING: Explosion hazard when used in potentially explosive areas

Please make sure that the following notes and instructions are observed.

- Observe the specified conditions for use in potentially explosive areas.
- At the time of installation, use an approved housing (minimum protection IP54), which meets the requirements of EN 60079-15. Within this context, observe the requirements of IEC 60079-14/EN 60079-14.
- In zone 2, only connect devices to the supply and signal circuits that are suitable for operation in the Ex zone 2 and the conditions at the installation location.
- In potentially explosive areas, only connect and disconnect cables when the power is disconnected.
- The device must be stopped and immediately removed from the Ex area if it is damaged, was subject to an impermissible load, stored incorrectly or if it malfunctions.
- The connection to the D-SUB interface is only permitted if the screw connection is tightened.

7 Function

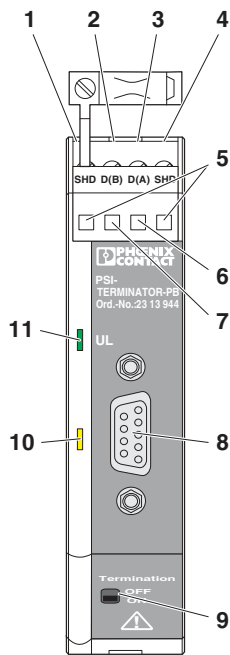

Figure 1 Function elements

- 1 U_{S1} , 24 V DC voltage supply
- 2 GND, 0 V voltage supply
- 3 U_{S2} , 24 V DC voltage supply
- 4 GND, 0 V voltage supply
- 5 SHD, shield connection
- 6 D(A), negative, PROFIBUS (green cable) / RS-485 connection
- 7 D(B), positive, PROFIBUS (red cable) / RS-485 connection
- 8 D-SUB, programming interface
- 9 Slide switch for termination resistor
- 10 LED, yellow, data activity
- 11 LED, green, UL, voltage supply

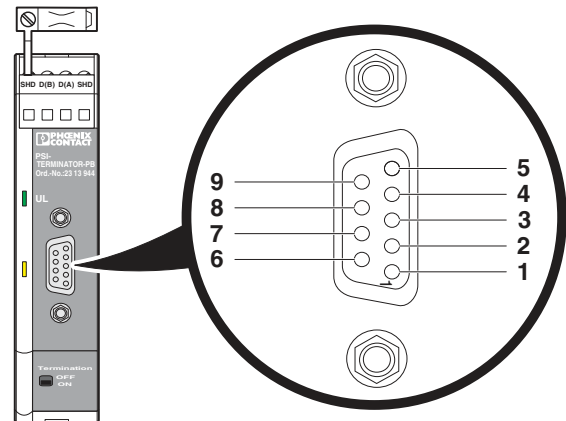

Figure 2 D-SUB, programming interface

- 1 Not used
- 2 Not used
- 3 D(B), positive data
- 4 Not used
- 5 GND, 0 V
- 6 +5 V
- 7 Not used
- 8 D(A), negative data
- 9 Not used

8 Basic circuit diagram

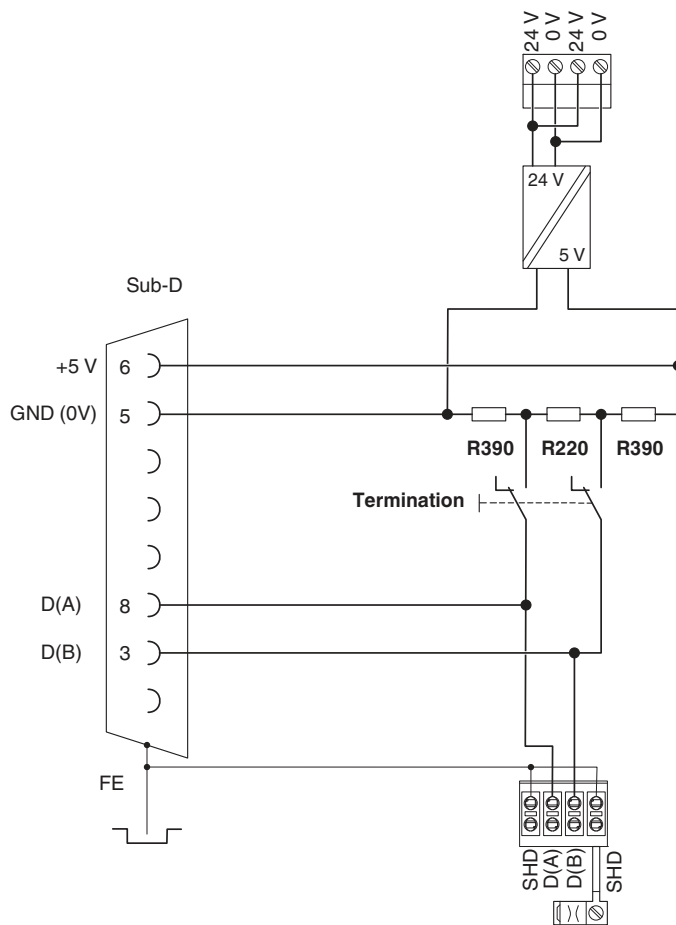

Figure 3 Block diagram

9 Dimensional drawing

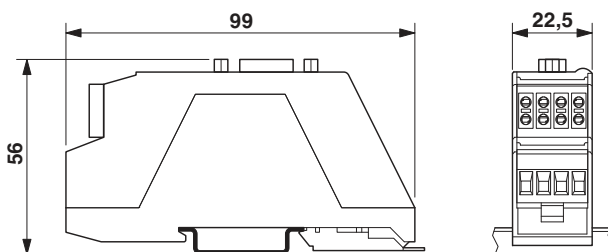

Figure 4 Dimensions

10 Install shield clip



NOTE: Interference

Connect the DIN rail to protective earth ground using a grounding terminal block. The device is grounded when it is snapped onto the DIN rail (installation according to PELV). Make a low-resistance connection to protective earth ground.

- Insert the shield connection clamp(s) into the spring-cage terminal block.

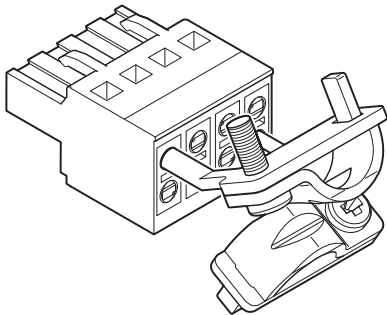

Figure 5 Install shield clip

- Fold back 10 mm of the braided shield over the outer cable sheath.

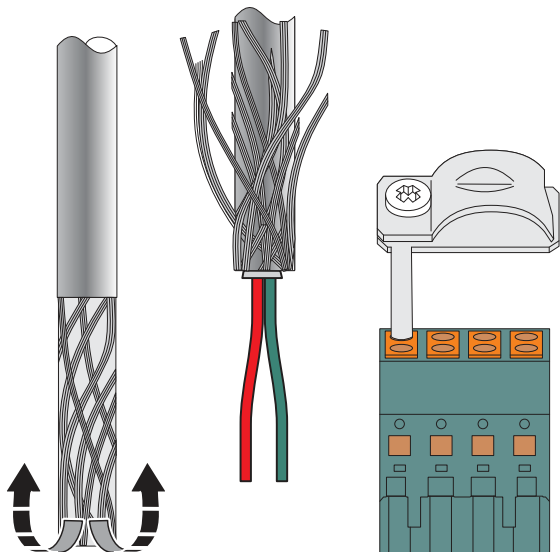

Figure 6 Push the braided shield back

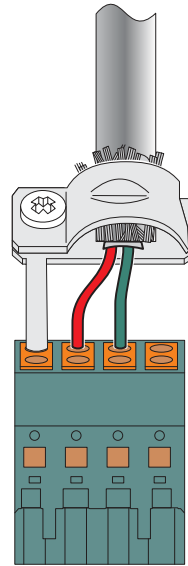

Figure 7 Connecting cables with a shield clip

11 Install signal cable

Integrate the PSI-TERMINATOR-PB into the bus system by connecting the incoming and outgoing bus cable to the spring-cage terminal block.

Pay attention to the application examples in the last section.

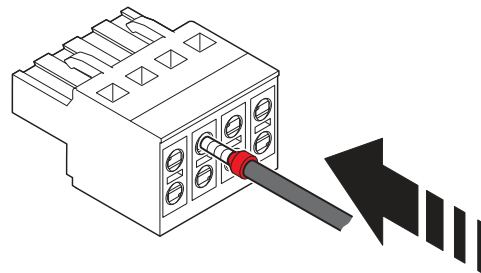

Figure 8 Install signal cable

- Connect the incoming and outgoing bus line to the plug-in spring-cage terminal block.
- Rigid conductors / ferrule assembled conductors: Insert the conductors directly into the terminal block without using a tool.
- Stranded conductors: Open the terminal first. Insert a screwdriver into the release slot above the connection terminal block (A1).

12 Deinstall signal cable

Depending on the mounting position, you have different possibilities for releasing the cable again:

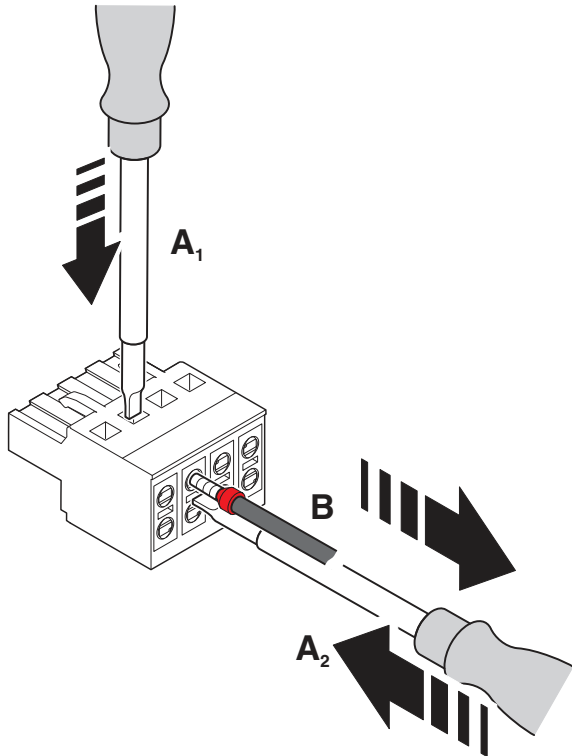

Figure 9 Deinstall signal cable

- Insert a screwdriver into the release slot above the connection terminal block (A1) or press with the screwdriver on the spring opener (A2).
- Remove the conductor from the terminal block (B).

13 Supply voltage

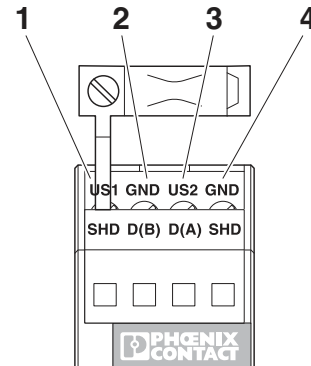

Figure 10 Power supply

- 1 U_{S1} , 24 V DC voltage supply
- 2 GND, 0 V voltage supply
- 3 U_{S2} , 24 V DC voltage supply
- 4 GND, 0 V voltage supply

- Supply voltage to the device via terminal blocks 1 (24 V) and 2 (0 V).

Terminal blocks 3 and 4 can be used as an alternative connection for the power supply. You can supply further devices in a group in this way.

A second power supply unit can be used to create a redundant supply concept.

14 Application examples

When the terminator is missing, communication is quickly disrupted in bus systems with changing bus users. For example, this occurs in the following applications:

Automatic vehicles

Mobile devices such as conveying vehicles if they regularly log in and out of processing stations for example. PSI-TERMINATOR-PB is used to ensure a defined state on the bus, if the device is not connected.

Exchangeable tools

The PSI-TERMINATOR-PB is suitable for use on robots that are equipped with a bus interface and produce using various exchangeable tools.

Motor Control Center (MCC)

The PSI-TERMINATOR-PB is suitable for ensuring bus termination when changing MCC racks. In these applications, the PSI-TERMINATOR-PB is installed after the last bus device in the cable. The bus cable is permanently terminated when the termination resistor at the device is switched on.

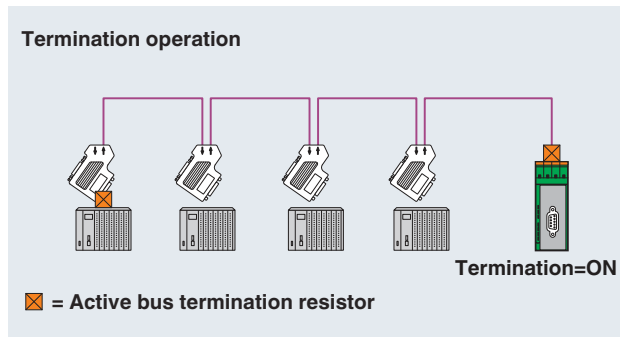

Service and programming

The PSI-TERMINATOR-PB is integrated into the bus system as a fixed interface and is used as a programming interface. Termination is deactivated in this mode of operation. Passive and active programming devices are supported.

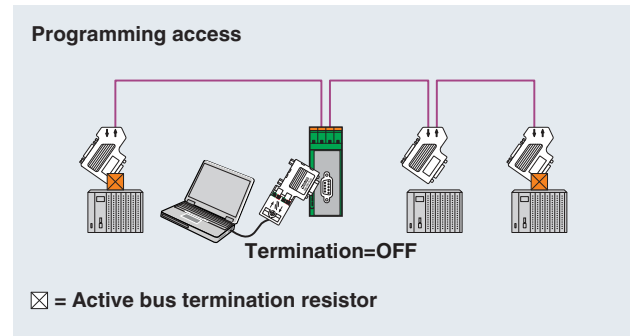

NOTE: Malfunction

Termination must not take place in the device or the D-SUB connector plug. The signal quality of the continuing bus is impacted otherwise.



Do **not** use the device as an access for diagnostic measurements. The branch line falsifies the measurements.