

ADS8344EVM

User's Guide

IMPORTANT NOTICE

Texas Instruments Incorporated and its subsidiaries (TI) reserve the right to make corrections, modifications, enhancements, improvements, and other changes to its products and services at any time and to discontinue any product or service without notice. Customers should obtain the latest relevant information before placing orders and should verify that such information is current and complete. All products are sold subject to TI's terms and conditions of sale supplied at the time of order acknowledgment.

TI warrants performance of its hardware products to the specifications applicable at the time of sale in accordance with TI's standard warranty. Testing and other quality control techniques are used to the extent TI deems necessary to support this warranty. Except where mandated by government requirements, testing of all parameters of each product is not necessarily performed.

TI assumes no liability for applications assistance or customer product design. Customers are responsible for their products and applications using TI components. To minimize the risks associated with customer products and applications, customers should provide adequate design and operating safeguards.

TI does not warrant or represent that any license, either express or implied, is granted under any TI patent right, copyright, mask work right, or other TI intellectual property right relating to any combination, machine, or process in which TI products or services are used. Information published by TI regarding third-party products or services does not constitute a license from TI to use such products or services or a warranty or endorsement thereof. Use of such information may require a license from a third party under the patents or other intellectual property of the third party, or a license from TI under the patents or other intellectual property of TI.

Reproduction of information in TI data books or data sheets is permissible only if reproduction is without alteration and is accompanied by all associated warranties, conditions, limitations, and notices. Reproduction of this information with alteration is an unfair and deceptive business practice. TI is not responsible or liable for such altered documentation.

Resale of TI products or services with statements different from or beyond the parameters stated by TI for that product or service voids all express and any implied warranties for the associated TI product or service and is an unfair and deceptive business practice. TI is not responsible or liable for any such statements.

Mailing Address:

Texas Instruments
Post Office Box 655303
Dallas, Texas 75265

EVM IMPORTANT NOTICE

Texas Instruments (TI) provides the enclosed product(s) under the following conditions:

This evaluation kit being sold by TI is intended for use for **ENGINEERING DEVELOPMENT OR EVALUATION PURPOSES ONLY** and is not considered by TI to be fit for commercial use. As such, the goods being provided may not be complete in terms of required design-, marketing-, and/or manufacturing-related protective considerations, including product safety measures typically found in the end product incorporating the goods. As a prototype, this product does not fall within the scope of the European Union directive on electromagnetic compatibility and therefore may not meet the technical requirements of the directive.

Should this evaluation kit not meet the specifications indicated in the EVM User's Guide, the kit may be returned within 30 days from the date of delivery for a full refund. **THE FOREGOING WARRANTY IS THE EXCLUSIVE WARRANTY MADE BY SELLER TO BUYER AND IS IN LIEU OF ALL OTHER WARRANTIES, EXPRESSED, IMPLIED, OR STATUTORY, INCLUDING ANY WARRANTY OF MERCHANTABILITY OR FITNESS FOR ANY PARTICULAR PURPOSE.**

The user assumes all responsibility and liability for proper and safe handling of the goods. Further, the user indemnifies TI from all claims arising from the handling or use of the goods. Please be aware that the products received may not be regulatory compliant or agency certified (FCC, UL, CE, etc.). Due to the open construction of the product, it is the user's responsibility to take any and all appropriate precautions with regard to electrostatic discharge.

EXCEPT TO THE EXTENT OF THE INDEMNITY SET FORTH ABOVE, NEITHER PARTY SHALL BE LIABLE TO THE OTHER FOR ANY INDIRECT, SPECIAL, INCIDENTAL, OR CONSEQUENTIAL DAMAGES.

TI currently deals with a variety of customers for products, and therefore our arrangement with the user **is not exclusive**.

TI assumes **no liability for applications assistance, customer product design, software performance, or infringement of patents or services described herein**.

Please read the EVM User's Guide and, specifically, the EVM Warnings and Restrictions notice in the EVM User's Guide prior to handling the product. This notice contains important safety information about temperatures and voltages. For further safety concerns, please contact the TI application engineer.

Persons handling the product must have electronics training and observe good laboratory practice standards.

No license is granted under any patent right or other intellectual property right of TI covering or relating to any machine, process, or combination in which such TI products or services might be or are used.

Mailing Address:

Texas Instruments
Post Office Box 655303
Dallas, Texas 75265

EVM WARNINGS AND RESTRICTIONS

It is important to operate this EVM with a maximum input voltage of 5 V.

Exceeding the specified input range may cause unexpected operation and/or irreversible damage to the EVM. If there are questions concerning the input range, please contact a TI field representative prior to connecting the input power.

Applying loads outside of the specified output range may result in unintended operation and/or possible permanent damage to the EVM. Please consult the EVM User's Guide prior to connecting any load to the EVM output. If there is uncertainty as to the load specification, please contact a TI field representative.

During normal operation, some circuit components may have case temperatures greater than 60°C. The EVM is designed to operate properly with certain components above 60°C as long as the input and output ranges are maintained. These components include but are not limited to linear regulators, switching transistors, pass transistors, and current sense resistors. These types of devices can be identified using the EVM schematic located in the EVM User's Guide. When placing measurement probes near these devices during operation, please be aware that these devices may be very warm to the touch.

Mailing Address:

Texas Instruments
Post Office Box 655303
Dallas, Texas 75265

Read This First

About This Manual

This users guide describes the characteristics, operation, and use of the ADS8344EVM 16-bit serial analog-to-digital converter evaluation board. A complete circuit description as well as schematic diagram and bill of materials is included.

How to Use This Manual

This document contains the following chapters:

- Chapter 1 – EVM Overview
- Chapter 2 – EVM Bill of Materials and Schematic

Related Documentation From Texas Instruments

To obtain a copy of any of the following TI documents, call the Texas Instruments Literature Response Center at (800) 477–8924 or the Product Information Center (PIC) at (972) 644–5580. When ordering, please identify this booklet by its title and literature number. Updated documents can also be obtained through our website at www.ti.com.

Data Sheets	Literature Number:
ADS8344	SBAS139C
OPA627	PDS998H
REF02	SBVS003A

FCC Warning

This equipment is intended for use in a laboratory test environment only. It generates, uses, and can radiate radio frequency energy and has not been tested for compliance with the limits of computing devices pursuant to subpart J of part 15 of FCC rules, which are designed to provide reasonable protection against radio frequency interference. Operation of this equipment in other environments may cause interference with radio communications, in which case the user at his own expense will be required to take whatever measures may be required to correct this interference.



Contents

1	EVM Overview	1-1
1.1	Features	1-2
1.2	Analog Interface	1-2
1.3	Digital Interface	1-3
1.4	Power Supplies	1-3
1.5	Reference Voltage	1-4
1.6	EVM Operation	1-4
2	EVM Bill of Materials and Schematic	2-1

Tables

1-1	Header/Socket Combination	1-2
1-2	Jumper Configuration	1-3
1-3	ADS8344EVM Interface	1-3
1-4	ADS8344EVM Power Supply	1-3
1-5	ADS8344EVM Onboard Reference	1-4
2-1	EVM Bill of Materials	2-1

EVM Overview

The ADS8344EVM is an 8-channel, 16-bit analog-to-digital converter board based on the ADS8344 ADC. Typical power dissipation is 10 mW at a 100 kHz throughput rate and a 5-V supply. The device uses a synchronous serial interface that is buffered on the EVM.

The EVM also incorporates a stable voltage reference and operational amplifier, configured as a buffer to ensure a low-noise voltage to the ADC.

Topic	Page
1.1 Features	1-2
1.2 Analog Interface	1-2
1.3 Digital Interface	1-3
1.4 Power Supplies	1-3
1.5 Reference Voltage	1-4
1.6 EVM Operation	1-4

1.1 Features

- Full-featured evaluation board for the ADS8344 100-kHz, 16-Bit, 8-channel analog-to-digital converter
- Onboard reference
- Signal conditioning available

1.2 Analog Interface

For maximum flexibility, the ADS8344EVM is designed for easy interfacing to multiple analog sources. The amplifier is arranged in a noninverting configuration.

Samtec part numbers SSW-110-22-F-D-VS-K and TSM-110-01-T-DV-P provide a convenient ten-pin dual row header/socket combination at P1. This header/socket provides access to the analog input pins of the ADS8344. Consult Samtec at www.samtec.com or 1-800-SAMTEC-9 for a variety of mating connector options.

Table 1–1. Header/Socket Combination

Pin Number	Signal	Description
P1.2	CH0	Channel 0 input, can be direct from connector or through op amp
P1.4	CH1	Channel 1 input, direct from P1 connector
P1.6	CH2	Channel 2 input, direct from P1 connector
P1.8	CH3	Channel 3 input, direct from P1 connector
P1.10	CH4	Channel 4 input, direct from P1 connector
P1.12	CH5	Channel 5 input, direct from P1 connector
P1.14	CH6	Channel 6 input, direct from P1 connector
P1.16	CH7	Channel 7 input, direct from P1 connector
P1.18	Reserved	
P1.20	REF+	External reference input

The appropriate jumpers are configured to enable the input for channel 0 to be derived from the onboard dual-supply op-amp.

Table 1–2. Jumper Configuration

Reference Designator	Description	Factor Set Condition	
		1–2	2–3
W1	Enables reference offset for single-supply amplifiers	Not installed	N/A
W3	Input source for channel 0	Onboard amplifier, U1	P1.2

1.3 Digital Interface

The ADS8344EVM is designed for easy interfacing to multiple platforms. Samtec part numbers SSW–110–22–F–D–VS–K and TSM–110–01–T–DV–P provide a convenient 10-pin dual row header/socket combination at P2. This header/socket provides access to the digital control and serial data pins of the ADS8344. Consult Samtec at www.samtec.com or 1–800–SAMTEC–9 for a variety of mating connector options.

Table 1–3. ADS8344EVM Interface

Pin Number	Signal	Description
J2.1	CS	Chip select—Active low signal, enables data transfer and device configuration
J2.3	SCLK	Serial clock
J2.5	Reserved	
J2.7	Reserved	
J2.9	Reserved	
J2.11	SDI	Serial data in
J2.13	SDO	Serial data out
J2.15	BUSY	Indicates internal state of ADC
J2.17	Reserved	
J2.19	Reserved	

1.4 Power Supplies

The ADS8344EVM board can accept three power supplies.

- A dual ± 12 V dc supply for the dual-supply op-amps and also to power the voltage reference.
- A single 2.7-V to 5-V dc supply for the ADC and the digital interface.

Table 1–4. ADS8344EVM Power Supply

Reference Designator	Description	Factor Set Condition	
		1–2	2–3
W2	Negative supply for amplifiers	–12 V, via J3.4	AGND
W4	Positive supply for amplifiers	12 V, via J3.2	V _{CC} , via J3.1

1.5 Reference Voltage

The ADS8344EVM can be configured to use its onboard reference, or external reference source, via W5.

Table 1–5. ADS8344EVM Onboard Reference

Reference Designator	Description	Factor Set Condition	
		1–2	2–3
W5	Reference is derived from onboard source	Installed	Not installed
	Reference is derived from P1.20	Not installed	Installed

1.6 EVM Operation

Apply the appropriate current limited (500 mA maximum) dc sources to J3 prior to connecting the analog input signals and digital control signals. The digital control signals can be applied directly to P2, or the ADS8344EVM can be connected to a DSP interface board.

A number of interface options are available for this style of EVM. Consult the product folder for a complete list of DSP interface cards and optional analog interface modules. If the interface options listed are not suitable, contact the PIC for the latest information.

EVM Bill of Materials and Schematic

The following table contains a complete bill of materials for the ADS8344 EVM. The schematic diagram is also provided for reference. Contact the product information center or e-mail dataconvapps@list.ti.com for questions regarding this EVM.

Table 2–1. EVM Bill of Materials

Ref Des	Description	Vendor	Part Number
R10 R12 R19	1/16 W 5% 0-R chip resistor	Panasonic	ERJ-3GEY0R00V
R2, R3, R4, R5, R6, R7, R8, R9, R11	1/16 W 5% 33-R chip resistor	Panasonic	ERJ-3GEYJ330V
R13 R14 R15 R16	1/16 W 1% 100-R chip resistor	Panasonic	ERJ-3GEYJ101V
R17	1/16 W 1% chip resistor	Panasonic	ERJ-3GEYJ102V
C24	10-pF, 50-V ceramic chip capacitor, ±0.5 pF, NPO	Panasonic	ECJ-2VC1H100D
C10, C13, C17, C19, C22, C23, C26, C28, C30	0.1-μF,-25-V ceramic chip capacitor, +80% –20%, Y5V	Panasonic	ECJ-1VF1E104Z
C29	0.1-μF, 50-V ceramic chip capacitor, ±10%, X7R	Panasonic	ECJ-2YB1H104K
C1, C9, C14, C16	10-μF, 16-V VS series electrolytic	Panasonic	ECE-V1CA100SR
C12, C15, C18	10-μF, Low profile tantalum capacitor	Panasonic	ECS-T1CX106R
C21, C25, C27	Not used		
C2, C3, C4, C5, C6, C7, C8, C11	47-nF, 16-V ceramic capacitor, 80% –20%	Murata	GRM39Y5V473Z016AD
FB1, FB2, FB3	Ferrite bead inductor	Fair-Rite	2744044447
U1	Precision single amplifier	Texas Instruments	OPA627AU
U2	ADS8344	Texas Instruments	ADS8344EB
U3	REF 02 5-V voltage regulator	Texas Instruments	REF02BU
U5	Precision single amplifier	Texas Instruments	OPA132AU
U6, U7	Single IC buffer driver with open drain o/p	Texas Instruments	SN74LVC1G07DBVR
N/A	ADS8344EVM PWB	Texas Instruments	6434957
AGND1, DGND1	Miniature test point terminal	Keystone Electronics	5000
P1, P2	20 Pin SMT plug	Samtec	SSW-110-22-F-D-VS-K
J1, J2	20 pin SMT socket	Samtec	TSM-110-01-T-DV-P
W1	2 Position jumper, 0.1" spacing	Samtec	TSW-102-07-L-S
W2, W3, W4, W5, W6	3 Position Jumper, 0.1" spacing	Samtec	TSW-103-07-L-S
J3	4-terminal screw connector	Lumberg	KRMZ4

Revision History		
REV	ECN Number	Approved

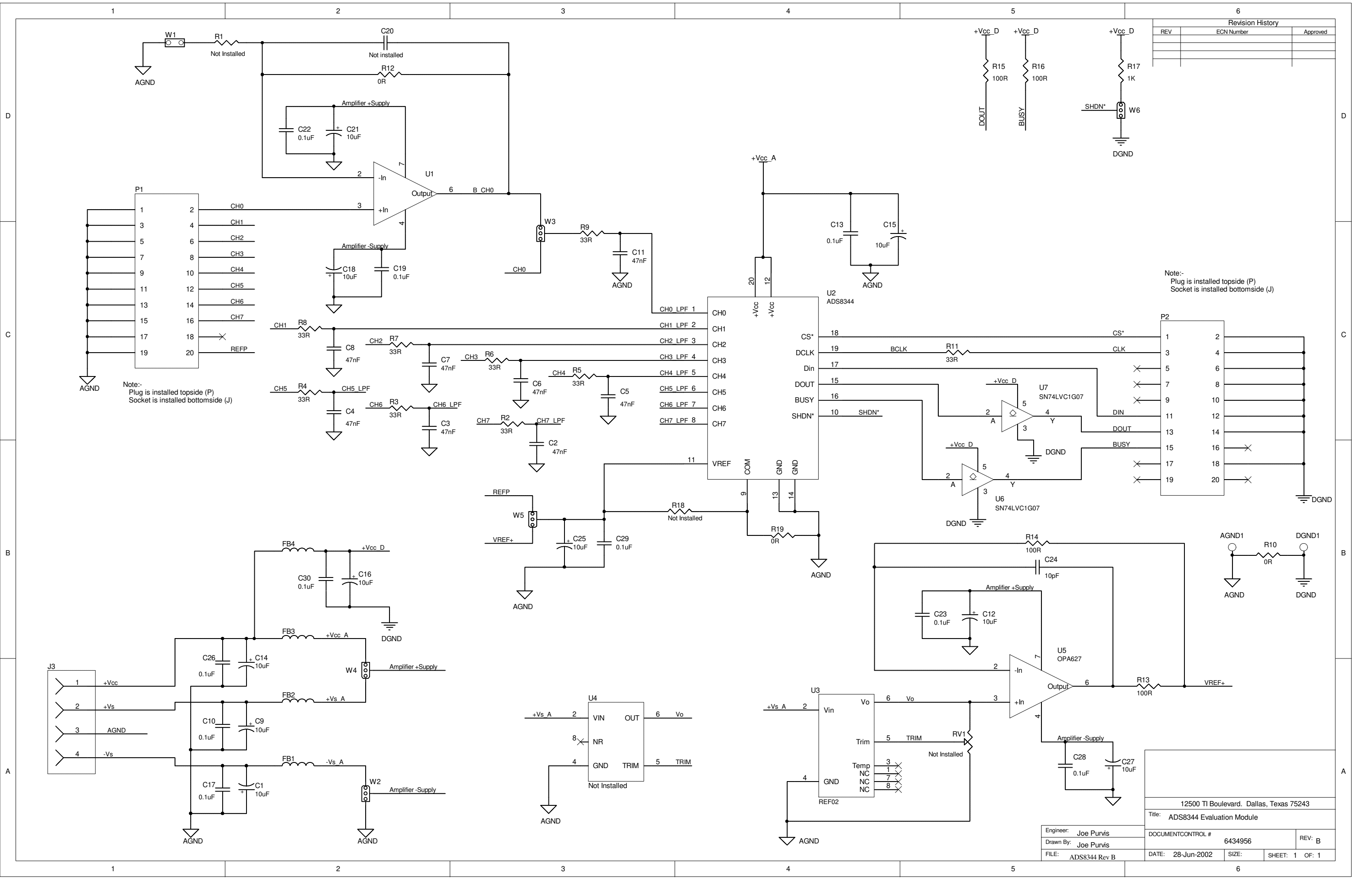

Note:-
Plug is installed topside (P)
Socket is installed bottomside (J)

Note:-
Plug is installed topside (P)
Socket is installed bottomside (J)

12500 TI Boulevard, Dallas, Texas 75243		
Title: ADS8344 Evaluation Module		
Engineer: Joe Purvis	DOCUMENTCONTROL # 6434956	REV: B
Drawn By: Joe Purvis	DATE: 28-Jun-2002	SIZE: SHEET: 1 OF: 1
FILE: ADS8344 Rev B		