

MATERIALS AND FINISHES

BODY ZINC ALLOY
PLATED NICKEL

CENTER CONTACT PHOSPHOR BRONZE
PLATED GOLD

INSULATOR POLYPROPYLENE (94-V0)

MOUNTING POST PHOSPHOR BRONZE
PLATED TIN

SOLDER TAIL COPPER OVER STEEL
PLATED TIN

JAM NUT BRASS
PLATED NICKEL

LOCK WASHER PHOSPHOR BRONZE
PLATED NICKEL

BNC JACK
75 OHM
INTERFACE

1/2-28 UNEF-2A
TOP VIEW

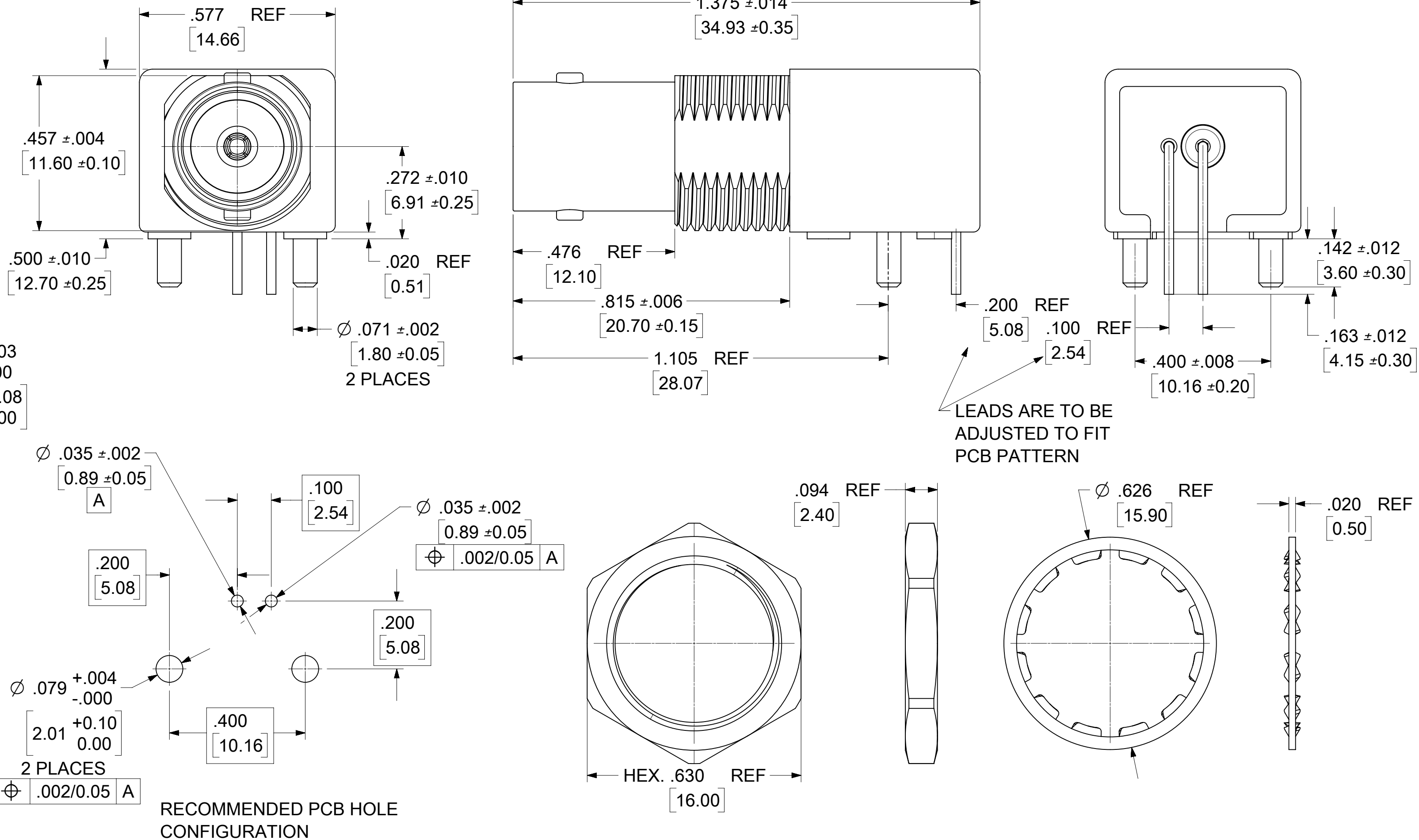
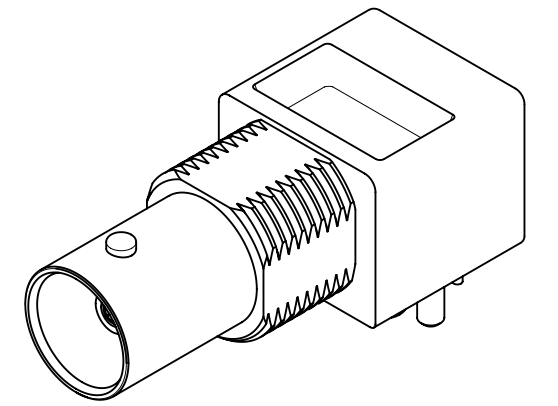

RECOMMENDED MOUNTING HOLE
PANEL THICKNESS: .216 (5.50) MAX
RECOMMENDED MOUNTING TORQUE:
1.36 N-m (12 INCH LBS) MAX

RECOMMENDED PCB HOLE
CONFIGURATION

73171-4340	QTY (1) OF 73101-0400 IN SINGLE BAG WITH LABEL
73101-0401	WITH JAM NUT AND WASHER; PACKAGING BY TRAY
73101-0400	WITHOUT JAM NUT AND WASHER; PACKAGING BY TRAY
PART NO.	DESCRIPTION

PS-89675-1030	PRODUCT SPECIFICATION
SPECIFICATION	DESCRIPTION

A6	2018/03/26	ADD POST DIM .071±.002 PER EWR 11902
REV.	DATE	DESCRIPTION

THIS DRAWING CONTAINS INFORMATION THAT IS PROPRIETARY TO MOLEX ELECTRONIC TECHNOLOGIES, LLC AND SHOULD NOT BE USED WITHOUT WRITTEN PERMISSION

DIMENSION UNITS	SCALE	CURRENT REV	DESC:
HYBRID			
GENERAL TOLERANCES (UNLESS SPECIFIED)		EC NO: 174408	
ANGULAR TOL	± °	DRWN: CWEI02	2018/03/26
4 PLACES	±	CHK'D:	
3 PLACES	±	APPR:	
2 PLACES	±	INITIAL REVISION:	
1 PLACE	±	DRWN: MCHAN05	2007/06/12
0 PLACES	±	APPR: MHUANG	2007/06/12
DRAFT WHERE APPLICABLE MUST REMAIN WITHIN DIMENSIONS	THIRD ANGLE PROJECTION	DRAWING	SERIES
		C-SIZE	73101

molex			
BNC JACK, R/A PCB, 75 OHMS DIE CAST, RECEPTACLE BNC-J/RA/PCB			
PRODUCT CUSTOMER DRAWING			
DOCUMENT NUMBER	DOC TYPE	DOC PART	REVISION
SD-73101-040	PSD	001	A6
MATERIAL NUMBER	CUSTOMER	SHEET NUMBER	
	GENERAL MARKET	1 OF 1	