

CABLE ENTRY DIAMETER MINIMUM		REVISIONS			
HOUSING	CONTACT	REV	DESCRIPTION	DATE	APPROVED
.050	.012	01 ₃	REVISED	8/6/1998	<i>[Signature]</i> 8/6/1998

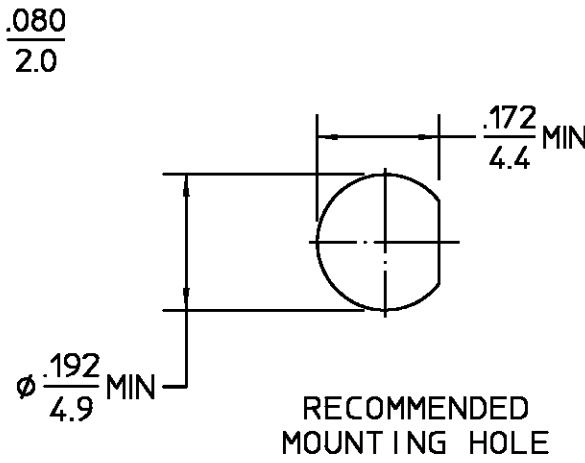
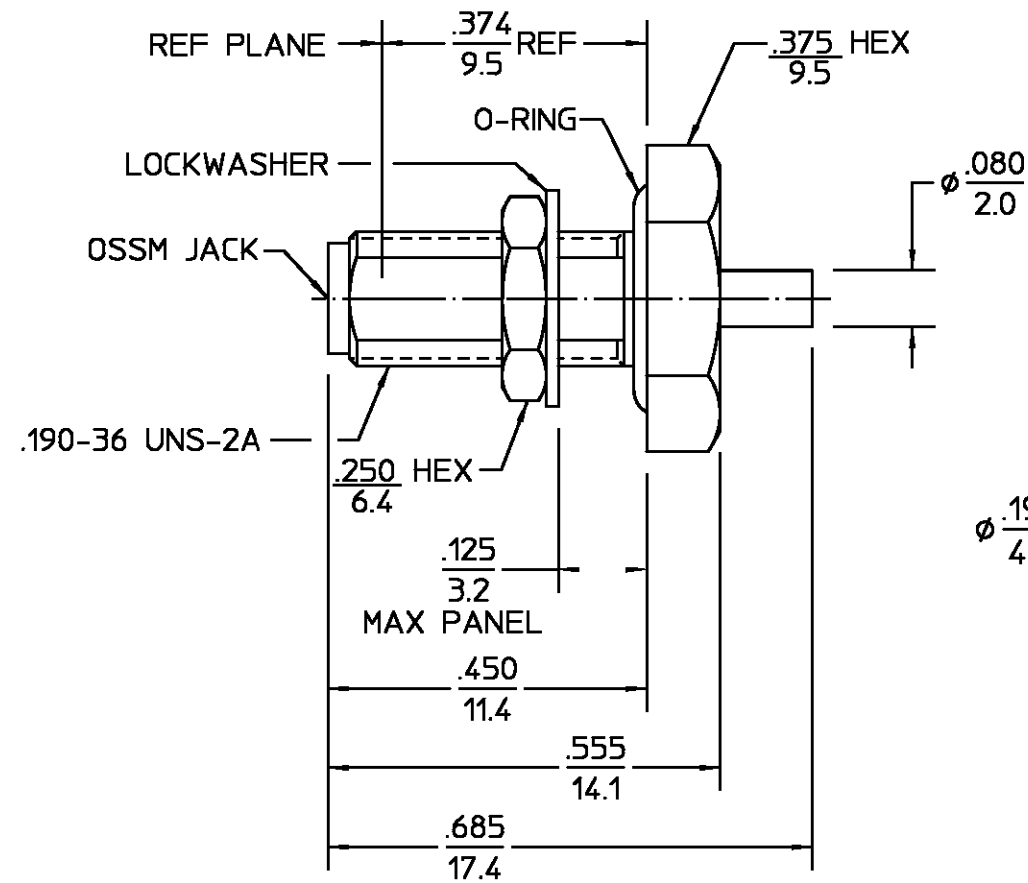

NOTES:
1. DESIGNED FOR USE WITH .047 DIA SEMI-RIGID CABLE

ELECTRICAL	MECHANICAL	ENVIRONMENTAL
Nominal Impedance (Ohms) <u>50</u>	Interface Dimensions MIL-STD-348, Fig. <u>319.2</u>	Temperature Rating <u>-65°C to 105°C</u>
Frequency Range (GHz) DC to <u>18</u>	Recommended Mounting Torque <u>5 In-Lbs</u>	Vibration MIL-STD-202, Method 204, Condition D
Volt Rating (VRMS MAX) @ Sea Level <u>125</u>	Mating Characteristics: Insertion (MAX Lbs) <u>3.0</u>	Shock MIL-STD-202, Method 213, Condition I
VSWR <u>1.15 +.01f(GHz)</u>	Withdrawal (MIN Oz) <u>1.0</u>	Thermal Shock MIL-STD-202, Method 107, Condition B, Except High Temp +115°C
Insertion Loss (dB MAX) <u>.08√f(GHz)</u>	Force to Engage and Disengage (In-Lbs MAX) <u>2.0</u>	Moisture Resistance MIL-STD-202, Method 106, Except Vibration
RF Leakage (dB MIN) <u>-[100-f(GHz)]</u>	Cable Retention Axial Force (Lbs) <u>25</u>	Shall Be Omitted
Corona, 70,000 Ft (VRMS MIN) <u>90</u>	Weight (Grams) <u>2.4</u>	Corrosion - MIL-STD-202, Method 101, Condition B, 5% salt spray
Dielectric Withstanding Voltage (VRMS MIN) @ Sea Level <u>500</u>		
Contact Resistance (Milliohms MAX) Center Contact <u>2.0</u>		
Outer Contact <u>2.0</u>		
Cable to Housing <u>0.5</u>		
RF High Potential @ Sea Level (VRMS MIN @ 5 MHz) <u>375</u>		
LR.(Megohms MIN) <u>5,000</u>		

COMPONENT	MATERIAL	FINISH
HOUSING MOUNTING NUT LOCKWASHER	STAINLESS STEEL PER ASTM-A484 AND ASTM-A582, TYPE 303	GOLD PLATE PER MIL-G-45204
DIELECTRIC	PTFE FLUOROCARBON PER ASTM-D-1457	N/A
CENTER CONTACT	BERYLLIUM COPPER PER ASTM-B-196 OR ASTM-B-197, ALLOY C17300, CONDITION H	GOLD PLATE PER MIL-G-45204
O-RING	SILICONE RUBBER PER ZZ-R-765	N/A

UNLESS OTHERWISE SPECIFIED DIMENSIONS ARE IN INCHES TOLERANCE ON	DRAWN BY <u>K.C.MAHER</u> DATE <u>6/5/90</u>	 AMP Incorporated 140 Fourth Avenue Waltham, MA 02451-7599								
FRAC. DEC. ANGLES	CHECKED BY									
$\pm 1/64$ $\pm .005$ $\pm 1^\circ$	APPD BY <u>S.T.M.</u> <u>6/6/90</u>									
These drawings and specifications are the property of M/A-COM Incorporated and shall not be reproduced or copied or used in whole or in part as the basis for the manufacture or sale of item(s) without written permission.	USE ASS'Y PROCEDURE	TITLE <u>OSSM BULKHEAD FEEDTHRU STRAIGHT CABLE JACK - DIRECT SOLDER ATTACHMENT</u>								
	NO. AP. <u>10-068</u> <u>(408-04760)</u>	<table border="1"> <tr> <td>SIZE <u>B</u></td> <td>CODE IDENT NO. <u>26805</u></td> <td><u>1004-7947-00</u></td> <td>REV <u>01₃</u></td> </tr> <tr> <td>SCALE <u>4:1</u></td> <td colspan="2"></td> <td>SHEET 1 OF 1</td> </tr> </table>	SIZE <u>B</u>	CODE IDENT NO. <u>26805</u>	<u>1004-7947-00</u>	REV <u>01₃</u>	SCALE <u>4:1</u>			SHEET 1 OF 1
SIZE <u>B</u>	CODE IDENT NO. <u>26805</u>	<u>1004-7947-00</u>	REV <u>01₃</u>							
SCALE <u>4:1</u>			SHEET 1 OF 1							

AMP PART # 1311708
SHEET 1 OF 1 REV A