

THIS DRAWING IS UNPUBLISHED. RELEASED FOR PUBLICATION  
 © COPYRIGHT - By - ALL RIGHTS RESERVED.

REVISIONS					
P	LTR	DESCRIPTION	DATE	DWN	APVD
C2		REVISED PER ECO-16-018632	05APR2017	SK	PO

TERMINAL NO ①

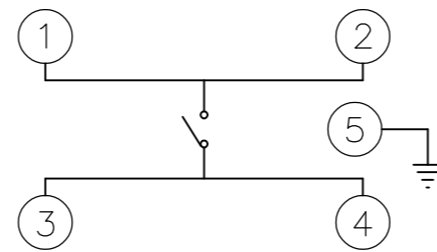
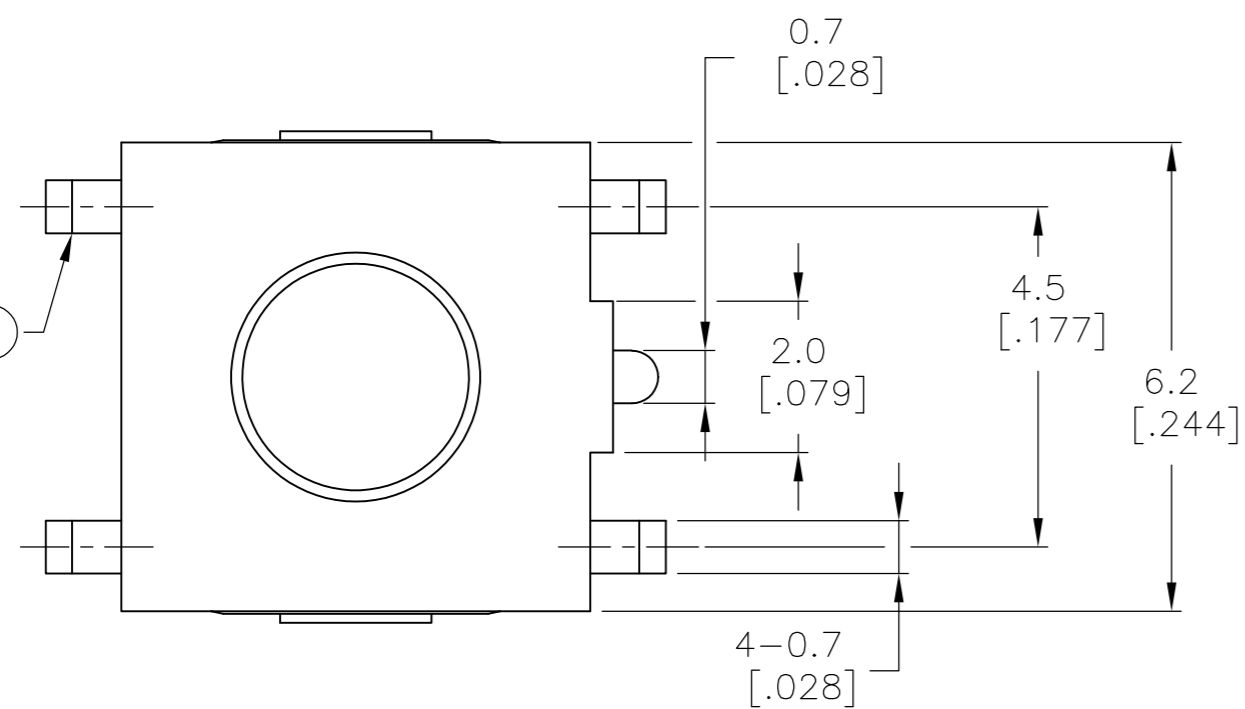

CIRCUIT DIAGRAM

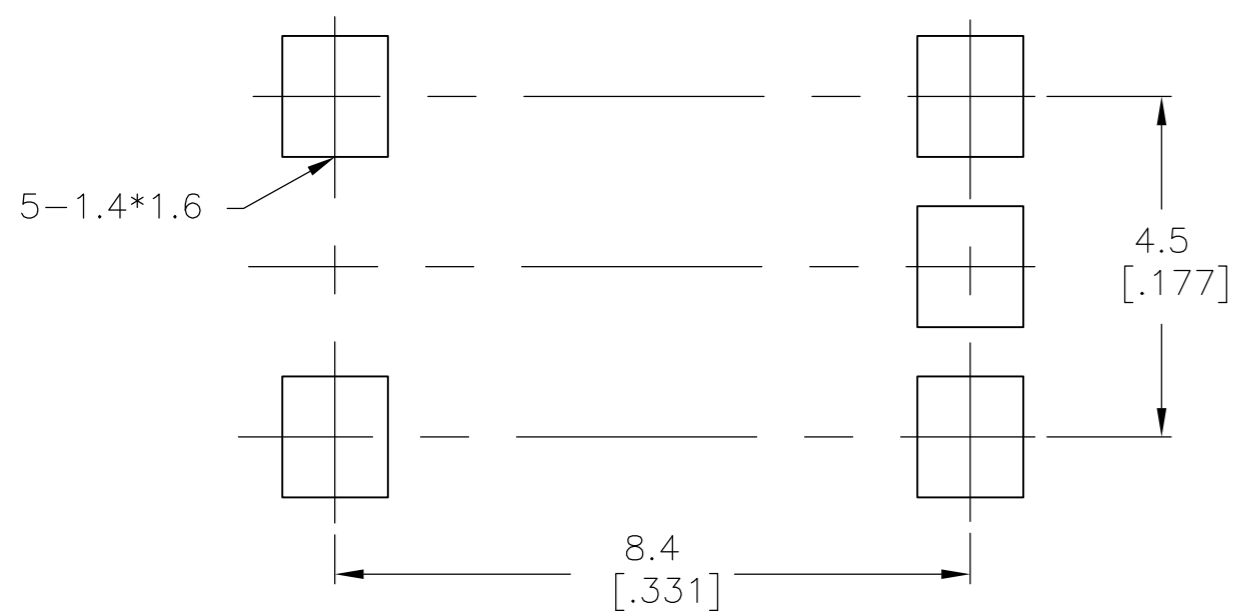
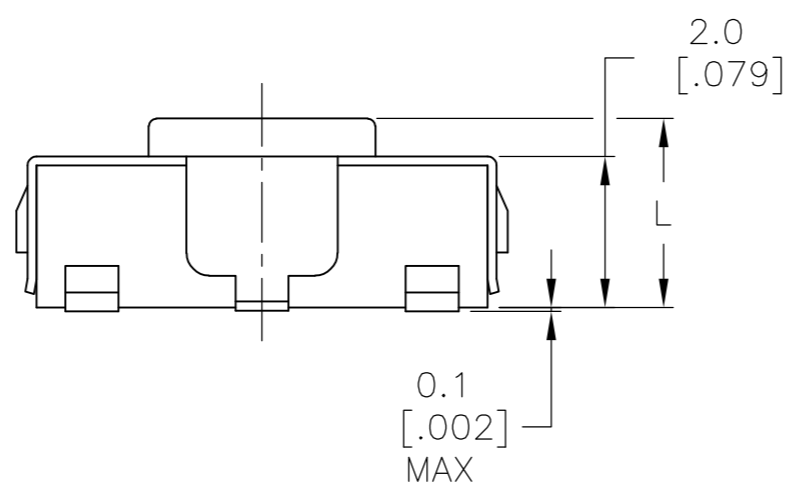
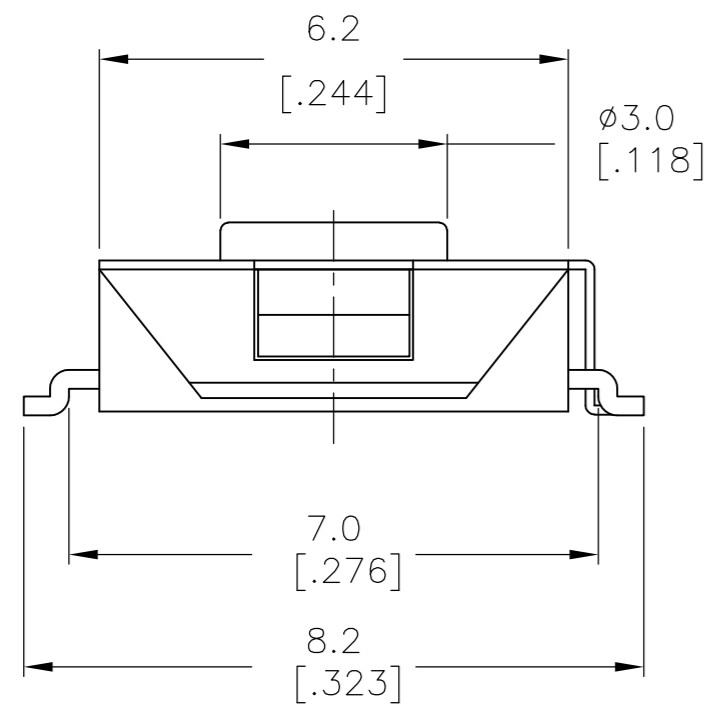

P.C.B MOUNTING SOLDER LAND DIMENSION

SPECIFICATIONS:

MATERIALS:

HOUSING, THERMOPLASTIC, UL94-V0, BLACK  
 ACTUATOR, THERMOPLASTIC, UL94-V0, COLOR SEE TABLE  
 TERMINAL, COPPER ALLOY, PLATE- SILVER OVER NICKEL  
 COVER, COPPER ALLOY, TIN PLATE  
 CONTACT, STAINLESS STEEL, SILVER PLATE

ELECTRICAL:

MAX CONTACT RATING: 50MILLIAMPS@24V DC  
 MIN CONTACT RATING: 10MICROAMPS@1V DC  
 INITIAL CONTACT RESISTANCE, 100 MILLIOHMS MAX, PER EIA-364-23B, EACH POSITION  
 INSULATION RESISTANCE, 100 MEGOHM MIN. PER EIA-364-21C EACH POSITION  
 DIELECTRIC STRENGTH, 500 V AC FOR 1 MINUTE, PER EIA-364-20B, CONDITION 1, EACH POSITION.  
 CONTACT BOUNCE, 10 MILLISECOND MAX, PER EIA 448-1B, METHOD 15

MECHANICAL:

ACTUATION FORCE, SEE TABLE  
 ACTUATION TRAVEL, .25 +/- .1mm  
 LIFE EXPECTANCY, SEE TABLE, VALUES GIVEN ARE MINIMUM, (2 CYCLES PER SECOND AND 150% ACTUATION FORCE), PER EIA-448 METHODS 8 & 9  
 VIBRATION, PER EIA 364-28D, CONDITION VII, LEVEL E, DURATION 1.5 HOURS  
 MECHANICAL SHOCK, PER EIA-364-27C, CONDITION A

ENVIRONMENTAL:

OPERATING TEMPERATURE, -35° TO +85°C, PER EIA-448, METHOD 10 (2 CYCLES PER SECOND)  
 STORAGE TEMPERATURE, -35° TO +85°C  
 HUMIDITY AND TEMPERATURE CYCLING PER EIA-364-31B, METHOD III  
 THERMAL SHOCK, PER EIA-364-32C, -35 TO +85 DEGREES C  
 SOLDERABILITY, PER EIA-364-52, CLASS 2, CATEGORY 1, TEMP, 245 DEGREES C MAX, TIME, 2.5 SECONDS MAX, 95% MINIMUM COVERAGE  
 RESISTANCE TO SOLDER HEAT, PER 109-201 COND B  
 1. NO CHANGE IN INITIAL ELECTRICAL AND MECHANICAL CHARACTERISTICS

NOTES:

- TAPE AND REEL PACKAGING PER EIA 481, TAPE WIDTH 12MM, PITCH 8.0MM, 3000 PER REEL
- ALL MATERIALS AND FINISHES SHALL COMPLY WITH EU DIRECTIVE 2002/95/EC OF 27JAN2003 (ROHS)

	COLOR	PACKAGING	CYCLE LIFE	FORCE	DIM L	PART NUMBER
	VIOLET	T&R	100,000	260±50gf	2.5mm	1-1571636-0
OBSOLETE	-VIOLET	BULK	100,000	260±50gf	2.5mm	1571636-9
	RED	T&R	1,000,000	160±50gf	2.0mm	1571636-8
	-RED	BULK	1,000,000	160±50gf	2.0mm	1571636-7
OBSOLETE	-RED	T&R	1,000,000	160±50gf	2.5mm	1571636-6
	-RED	BULK	1,000,000	160±50gf	2.5mm	1571636-5
	GREEN	T&R	1,000,000	100±50gf	2.5mm	1571636-4
OBSOLETE	-GREEN	BULK	1,000,000	100±50gf	2.5mm	1571636-3
	IVORY	T&R	1,000,000	50±30gf	2.5mm	1571636-2
OBSOLETE	-IVORY	BULK	1,000,000	50±30gf	2.5mm	1571636-1

THIS DRAWING IS A CONTROLLED DOCUMENT.		DWN M.BINNER 22SEP03				
DIMENSIONS: mm [INCHES]		CHK M.SARVER 22SEP03				
TOLERANCES UNLESS OTHERWISE SPECIFIED:		APVD M.SARVER 22SEP03	NAME PUSHBUTTON SWITCH, 6X6 mm, SMT, GULL WING, W/ESD TERMINAL			
0 PLC ± -		PRODUCT SPEC	SIZE			
1 PLC ± 0.3		APPLICATION SPEC	CAGE CODE			
2 PLC ± -			DRAWING NO			
3 PLC ± -			RESTRICTED TO			
4 PLC ± -			A2 00779 C=1571636			
ANGLES ± -			SCALE 10:1 SHEET 1 OF 1 REV C2			
FINISH		WEIGHT 0	CUSTOMER DRAWING			
SEE NOTES						