

Isolated Feedback Generator

FEATURES

- An Amplitude-Modulation System for Transformer Coupling an Isolated Feedback Error Signal
- Low-Cost Alternative to Optical Couplers
- Internal 1% Reference and Error Amplifier
- Internal Carrier Oscillator Usable to 5MHz
- Modulator Synchronizable to an External Clock
- Loop Status Monitor

DESCRIPTION

The UC1901 family is designed to solve many of the problems associated with closing a feedback control loop across a voltage isolation boundary. As a stable and reliable alternative to an optical coupler, these devices feature an amplitude modulation system which allows a loop error signal to be coupled with a small RF transformer or capacitor.

The programmable, high-frequency oscillator within the UC1901 series permits the use of smaller, less expensive transformers which can readily be built to meet the isolation requirements of today's line-operated power systems. As an alternative to RF operation, the external clock input to these devices allows synchronization to a system clock or to the switching frequency of a SMPS.

An additional feature is a status monitoring circuit which provides an active-low output when the sensed error voltage is within $\pm 10\%$ of the reference. The DRIVERB output, DRIVERA output, and STATUS output are disabled until the input supply has reached a sufficient level to allow proper operation of the device.

Since these devices can also be used as a DC driver for optical couplers, the benefits of 4.5 to 40V supply operation, a 1% accurate reference, and a high gain general purpose amplifier offer advantages even though an AC system may not be desired.

UC1901 SIMPLIFIED SCHEMATIC

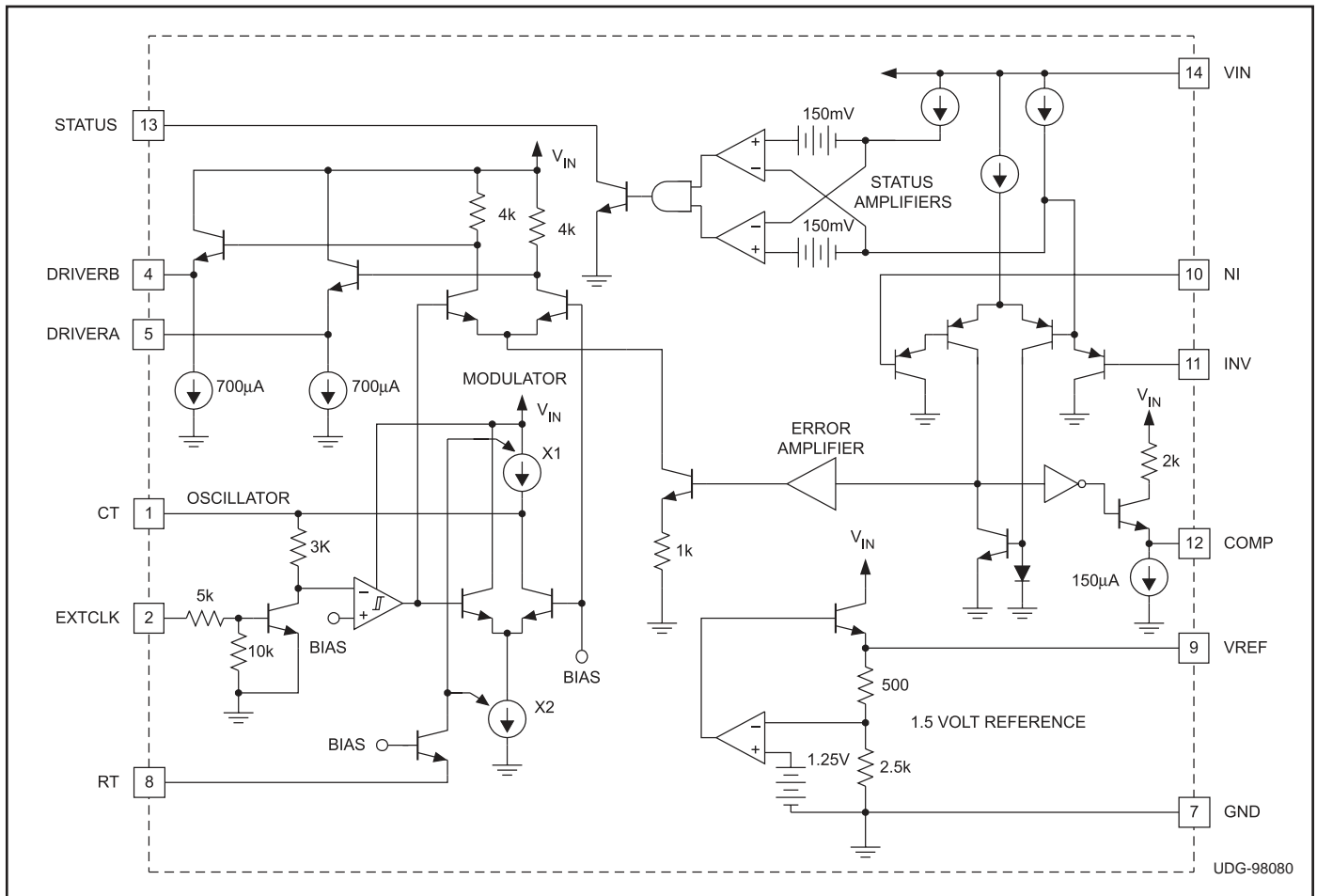

ABSOLUTE MAXIMUM RATINGS (Note 1)

Input Supply Voltage, V_{IN}	40V
Reference Output Current	-10mA
Driver Output Currents	-35mA
Status Indicator Voltage	40V
Status Indicator Current	20mA
Ext. Clock Input	40V
Error Amplifier Inputs	-0.5V to +35V
Power Dissipation at $T_A = 25^\circ\text{C}$	1000mW
Power Dissipation at $T_c = 25^\circ\text{C}$	2000mW
Operating Junction Temperature	-55°C to +150°C
Storage Temperature	-65°C to +150°C
Lead Temperature (Soldering, 10 seconds)	300°C

Note 1: Voltages are referenced to ground, Pin 7. Currents are positive into, negative out of the specified terminal.

Note 2: Consult Packaging section of Databook for thermal limitations and considerations of package.

CONNECTION DIAGRAMS

DIL-14, SOIC-14 (TOP VIEW) J or N Package, D Package

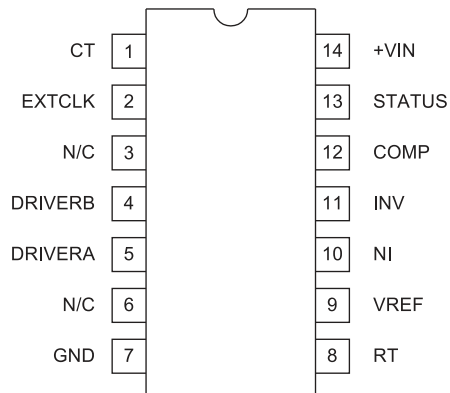

SOIC-16 Wide (TOP VIEW) DW Package

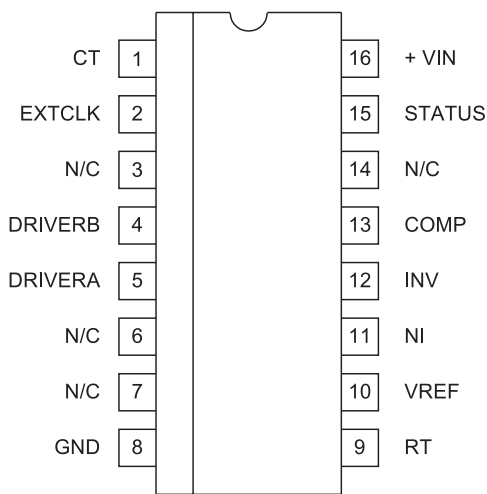

PLCC-20, LCC-20 (TOP VIEW) Q, L Packages

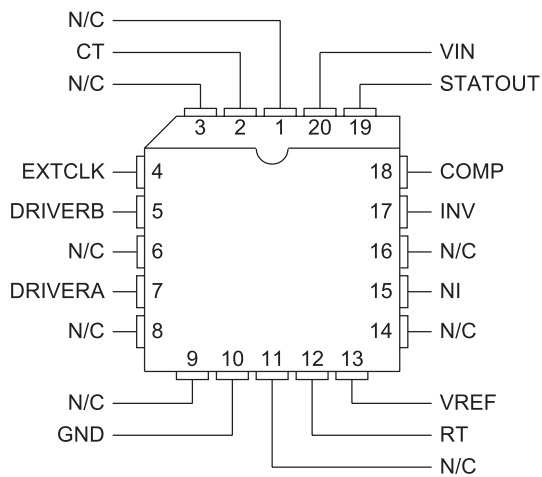

TEMPERATURE AND PACKAGE SELECTION GUIDE

	TEMPERATURE RANGE	AVAILABLE PACKAGES
UC1901	-55°C to +125°C	J, L
UC2901	-40°C to +85°C	D, DW, J, N, Q
UC3901	0°C to +70°C	D, DW, J, N, Q

ELECTRICAL CHARACTERISTICS Unless otherwise stated, these specifications apply for $V_{IN} = 10V$, $R_T = 10k\Omega$, $C_T = 820pF$, $T_A = T_J$.

PARAMETER	TEST CONDITIONS	UC1901/UC2901			UC3901			UNITS
		MIN	TYP	MAX	MIN	TYP	MAX	
Reference Section								
Output Voltage	$T_J = 25^\circ C$	1.485	1.5	1.515	1.47	1.5	1.53	V
	$T_{MIN} \leq T_J \leq T_{MAX}$	1.470	1.5	1.530	1.455	1.5	1.545	
Line Regulation	$V_{IN} = 4.5$ to $35V$		2	10		2	15	mV
Load Regulation	$I_{OUT} = 0$ to $5mA$		4	10		4	15	mV
Short Circuit Current	$T_J = 25^\circ C$		-35	-55		-35	-55	mV
Error Amplifier Section (To Compensation Terminal)								
Input Offset Voltage	$V_{CM} = 1.5V$		1	4		1	8	mV
Input Bias Current	$V_{CM} = 1.5V$		-1	-3		-1	-6	μA
Input Offset Current	$V_{CM} = 1.5V$		0.1	1		0.1	2	μA
Small Signal Open Loop Gain		40	60		40	60		dB
CMRR	$V_{CM} = 0.5$ to $7.5V$	60	80		60	80		dB
PSRR	$V_{IN} = 2$ to $25V$	80	100		80	100		dB
Output Swing, ΔV_o		0.4	0.7		0.4	0.7		V
Maximum Sink Current		90	150		90	150		μA
Maximum Source Current		-2	-3		-2	-3		mA
Gain Band Width Product			1			1		MHz
Slew Rate			0.3			0.3		V/ μS
Modulators/Drivers Section (From Compensation Terminal)								
Voltage Gain		11	12	13	10	12	14	dB
Output Swing		± 1.6	± 2.8		± 1.6	± 2.8		V
Driver Sink Current		500	700		500	700		μA
Driver Source Current		-15	-35		-15	-35		mA
Gain Band Width Product			25			25		MHz
Oscillator Section								
Initial Accuracy	$T_J = 25^\circ C$	140	150	160	130	150	170	kHz
	$T_{MIN} \leq T_J \leq T_{MAX}$	130		170	120		180	kHz
Line Sensitivity	$V_{IN} = 5$ to $35V$.15	.35		.15	.60	%/V
Maximum Frequency	$R_T = 10k$, $C_T = 10pF$		5			5		MHz
Ext. Clock Low Threshold	Pin 1 (C_T) = V_{IN}	0.5			0.5			V
Ext. Clock High Threshold	Pin 1 (C_T) = V_{IN}			1.6			1.6	V
Status Indicator Section								
Input Voltage Window	@ E/A Inputs, $V_{CM} = 1.5V$	± 135	± 150	± 165	± 130	± 150	± 170	mV
Saturation Voltage	E/A Δ Input = $0V$, $I_{SINK} = 1.6mA$			0.45			0.45	V
Max. Output Current	Pin 13 = $3V$, E/A Δ Input = $0.0V$	8	15		8	15		mA
Leakage Current	Pin 13 = $40V$, E/A Δ Input = $0.2V$.05	1		.05	5	μA
Supply Current	$V_{IN} = 35V$		5	8		5	10	mA
UVLO Section								
Drivers Enabled Threshold	At Input Supply V_{IN}		3.9	4.5		3.9	4.5	V
Status Output Enabled Threshold	At Input Supply V_{IN}		3.9	4.5		3.9	4.5	V
Change in Reference Output	When V_{IN} Reaches UVLO Threshold		-2	-30		-2	-30	mV

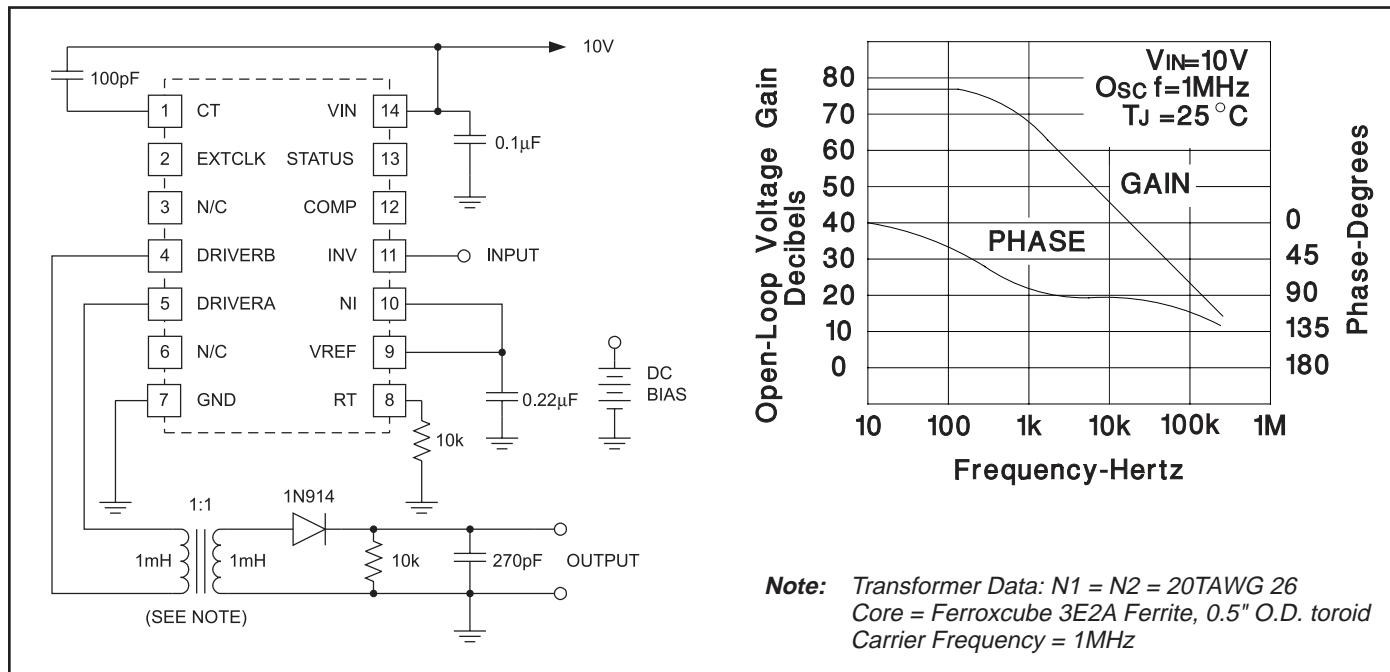

Figure 1. Transformer Coupled Open Loop Transfer Function

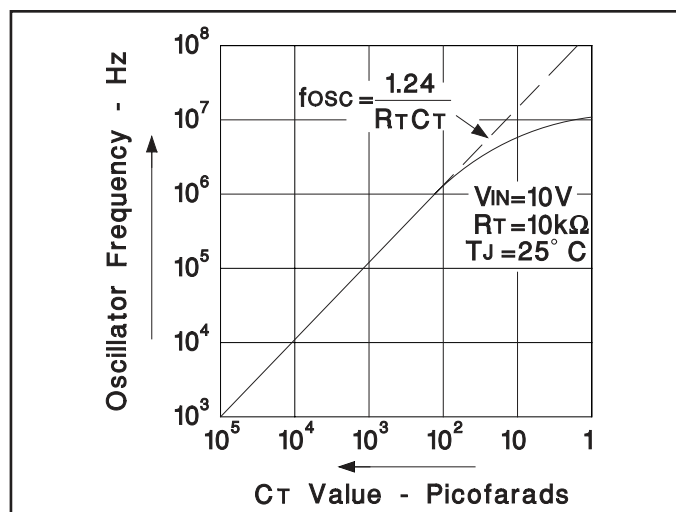

Figure 2. Oscillator Frequency

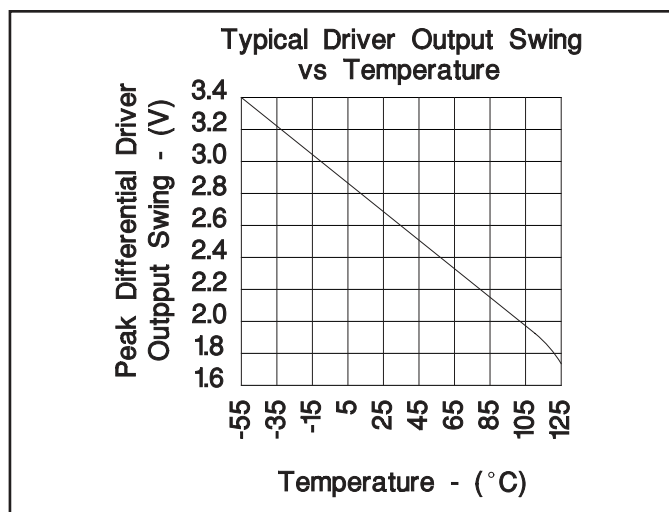

Figure 3. Typical Driver Output Swing vs Temperature

APPLICATION INFORMATION

The error amplifier compensation terminal, Pin 12, is intended as a source of feedback to the amplifier's inverting input at Pin 11. For most applications, a series DC blocking capacitor should be part of the feedback network. The amplifier is internally compensated for unity feedback.

The waveform at the driver outputs is a squarewave with an amplitude that is proportional to the error amplifier input signal. There is a fixed 12dB of gain from the error amplifier compensation pin to the modulator driver outputs. The frequency of the output waveform is controlled by either the internal oscillator or an external clock signal.

With the internal oscillator the squarewave will have a fixed 50% duty cycle. If the internal oscillator is disabled by connecting Pin 1, C_R , to V_{IN} then the frequency and duty cycle of the output will be determined by the input clock waveform at Pin 2. If the oscillator remains disabled and there is not clock input at Pin 2, there will be a linear 12dB of signal gain to one or the other of the driver outputs depending on the DC state of Pin 2.

The driver outputs are emitter followers which will source a minimum of 15mA of current. The sink current, internally limited at 700µA, can be increased by adding resistors to ground at the driver outputs.

APPLICATION INFORMATION (continued)

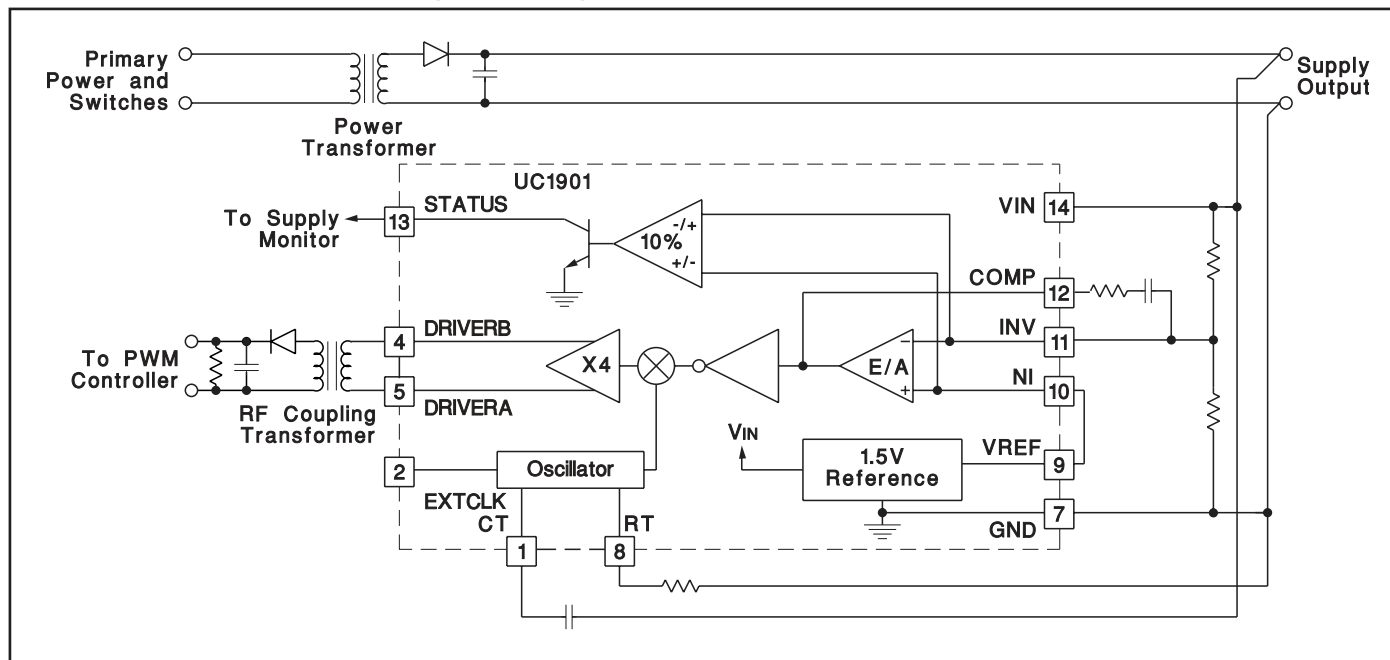

Figure 4. R.F. Transformer Coupled Feedback

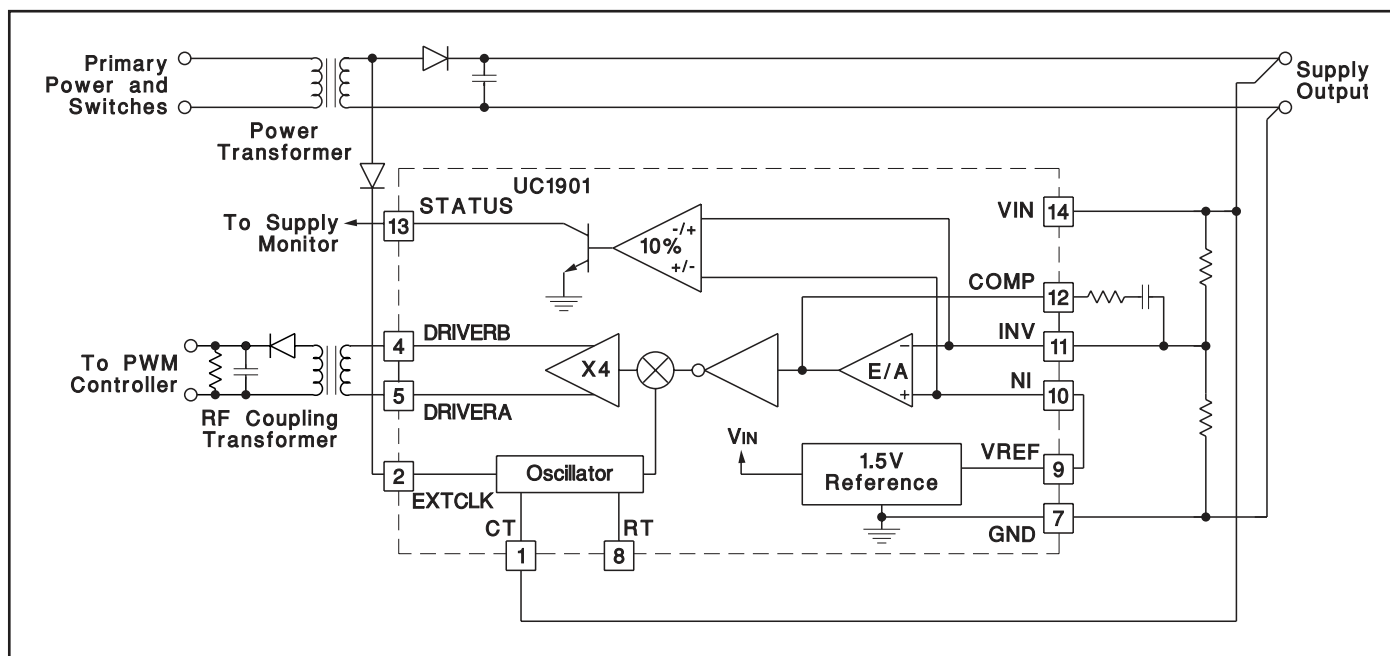

Figure 5. Feedback Coupled at Switching Frequency

TYPICAL APPLICATION

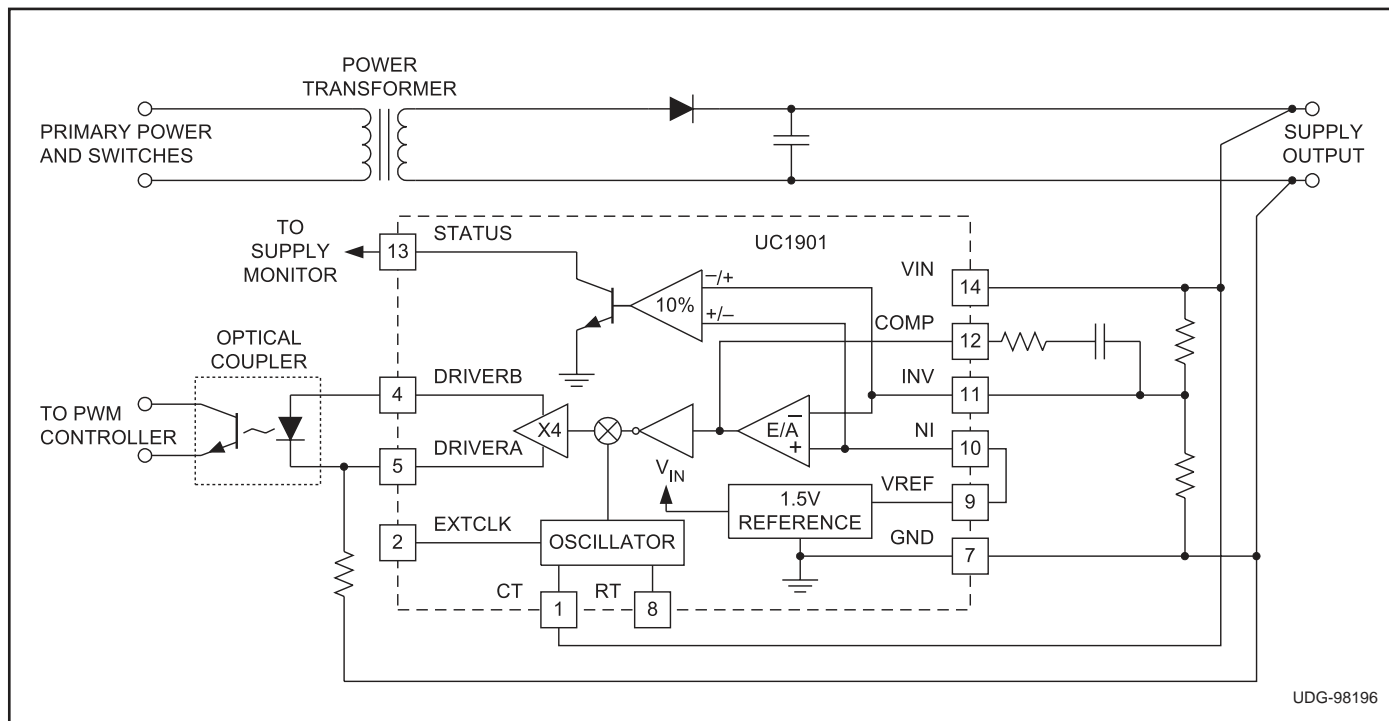

Figure 6. Optically Coupled DC Feedback