

M/N 75195-( )	-**0*	-**1*	-**2*	-**3*	-**4*	-**5*	-**6*	-**7*	-**8*
KEYING PIN ORIENTATION	NONE	A	B	C	D	E	F	G	H

75195 \* \* \* \*

PIN LENGTH/PLATING

- 1 = 4.75mm, 10 or 30 MICROINCH GOLD
- 2 = 6.25mm, 10 or 30 MICROINCH GOLD
- 3 = 4.25mm, 10 or 30 MICROINCH GOLD
- 4 = 5.15mm, 10 or 30 MICROINCH GOLD
- 6 = 4.75mm, 50 MICROINCH GOLD
- 7 = 6.25mm, 50 MICROINCH GOLD
- 8 = 4.25mm, 50 MICROINCH GOLD
- 9 = 5.15mm, 50 MICROINCH GOLD

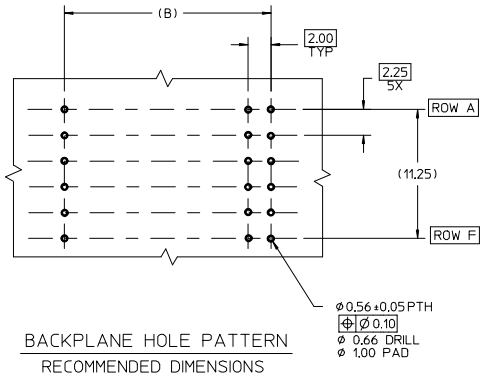
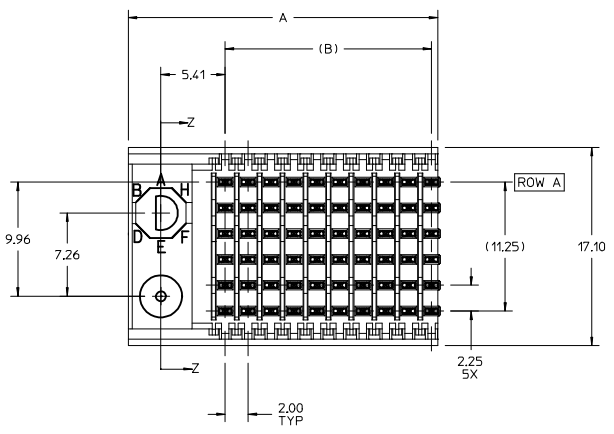

COLUMN/PLATING

- 10 = 10 COLUMN MATTE TIN (FORMERLY TIN/LEAD)
- 25 = 25 COLUMN MATTE TIN (FORMERLY TIN/LEAD)
- 60 = 10 COLUMN MATTE TIN (MAPS)
- 75 = 25 COLUMN MATTE TIN (MAPS)
- 90 = 10 COLUMN MATTE TIN
- 85 = 25 COLUMN MATTE TIN

- NOTES:
1. MATERIALS:  
HOUSING - LIQUID CRYSTAL POLYMER (LCP),  
GLASS-FILLED, UL 94V-0, COLOR: BLACK  
SIGNAL PIN - COPPER ALLOY
  2. FINISHES:  
CONTACT AREA: SELECTIVE GOLD (Au)  
PCB TAILS: SELECTIVE MATTE TIN (Sn)  
NICKEL (Ni) OVERALL.
  3. THIS PART CONFORMS TO MOLEX PRODUCT SPECIFICATION PS-74031-999.
  4. FOR MIXED CONTACT LENGTHS CONSULT MOLEX FOR AVAILABILITY.
  5. FOR SPECIFIC MATERIAL NUMBERS & MATING INFORMATION REFER TO SHEET 2.
  6. PACKAGE PER PK-74058-003.
  7. MARK PART WITH PART NUMBER & DATE CODE APPROXIMATELY WHERE SHOWN.
  8. MAPS (MOLEX ADVANCED PLATING SYSTEM)

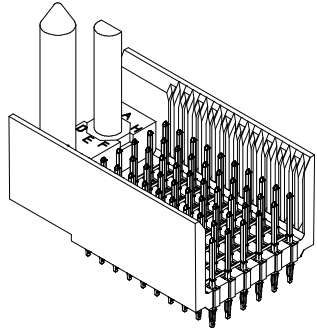
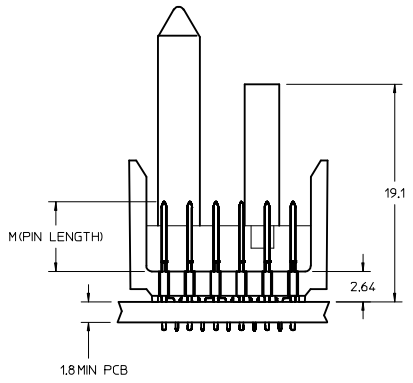
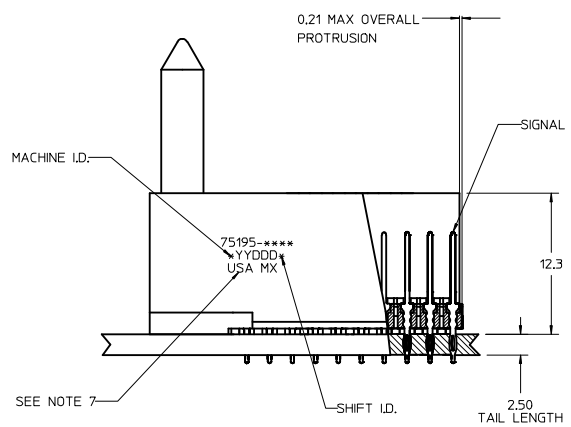

SEE SHEET 2 EC NO: UCP2013-4047 DRAWN BY: DRWNSVANG01 CHECKED BY: CHYKMOLE APPROVED BY: APPRSMILLER DATE: 2013/03/21 DATE: 2013/03/21 DATE: 2013/05/20	QUALITY SYMBOLS	GENERAL TOLERANCES (UNLESS SPECIFIED)	DIMENSION STYLE	SCALE	DESIGN UNITS	THIRD ANGLE PROJECTION
	▽=0 ▽=0 ▽=0	mm INCH 4 PLACES ±--- ±--- 3 PLACES ±--- ±--- 2 PLACES ±0.25 ±--- 1 PLACE ±0.38 ±--- 0 PLACE ± ±	MM ONLY	4:1	METRIC	
	ANGULAR ±1/2°	DRAFT WHERE APPLICABLE MUST REMAIN WITHIN DIMENSIONS	MATERIAL NO. SEE TABLE	DATE	TITLE	
			DATE	DATE	VHDM LITE 6 ROW, LF SIGNAL END BACKPLANE SALES DRAWING	
			DATE	DATE	molex	
			DATE	DATE	SD-75195-001	
			DATE	DATE		SHEET NO. 1 OF 2

PART NUMBER	COLUMN	NUMBER OF SIGNAL PIN	A	B	M	GOLD THICKNESS MICROMETER	MATTE TIN THICKNESS MICROMETER
<b>75195-60*1</b>	10	60	27.00	18.00	4.75	0.25 MAPS	0.76-152
75195-*0*1						0.76	
75195-*0*6						1.27	
<b>75195-75*1</b>	25	150	57.00	48.00	4.75	0.25 MAPS	
75195-*5*1						0.76	
75195-*5*6						1.27	
<b>75195-60*2</b>	10	60	27.00	18.00	6.25	0.25 MAPS	
75195-*0*2						0.76	
75195-*0*7						1.27	
<b>75195-75*2</b>	25	150	57.00	48.00	6.25	0.25 MAPS	
75195-*5*2						0.76	
75195-*5*7						1.27	
<b>75195-60*3</b>	10	60	27.00	18.00	4.25	0.25 MAPS	
75195-*0*3						0.76	
75195-*0*8						1.27	
<b>75195-75*3</b>	25	150	57.00	48.00	4.25	0.25 MAPS	
75195-*5*3						0.76	
75195-*5*8						1.27	
<b>75195-60*4</b>	10	60	27.00	18.00	5.15	0.25 MAPS	
75195-*0*4						0.76	
75195-*0*9						1.27	
<b>75195-75*4</b>	25	150	57.00	48.00	5.15	0.25 MAPS	
75195-*5*4						0.76	
75195-*5*9						1.27	

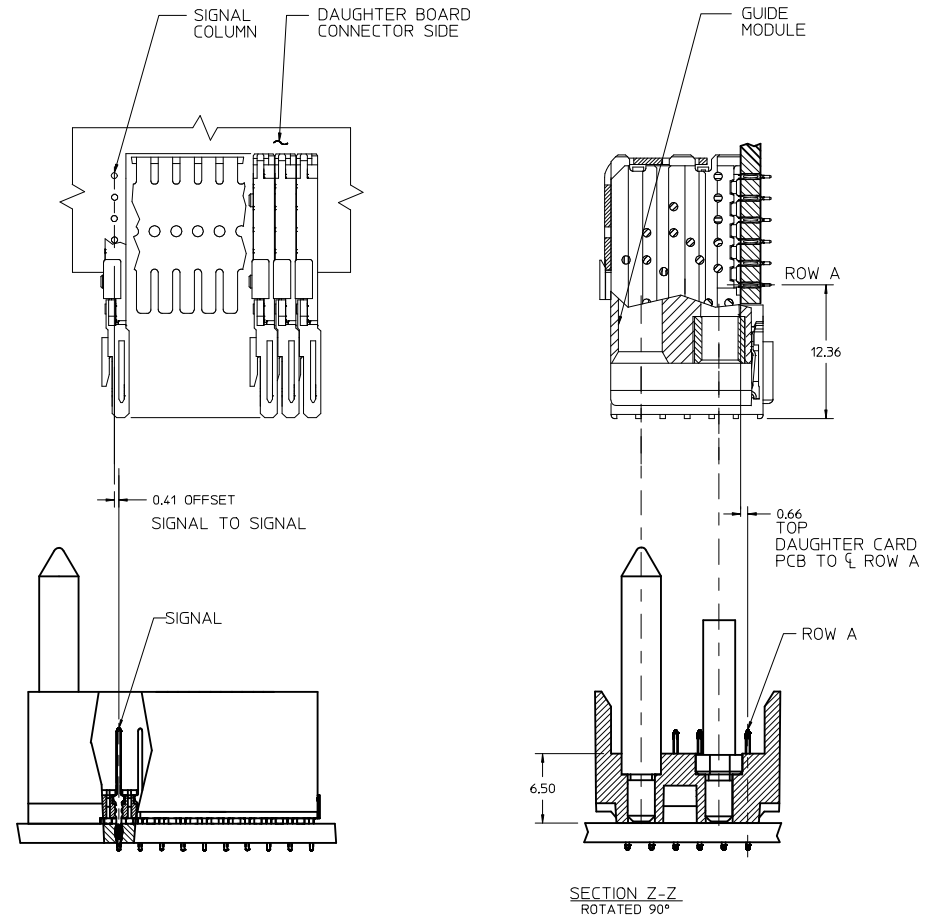

<b>REV. DIMENSIONS IN COL. A</b> EC NO: UCP2013-4047 DRAWN BY: 2013/03/21 CHYKSHOLEE APPROVED BY: 2013/05/20 APPR: SMILLER	QUALITY SYMBOLS	GENERAL TOLERANCES (UNLESS SPECIFIED)	DIMENSION STYLE	SCALE	DESIGN UNITS	THIRD ANGLE PROJECTION
	∇=0 ∇=0 ∇=0	4 PLACES ± mm INCH 3 PLACES ± mm INCH 2 PLACES ±0.25 mm INCH 1 PLACE ±0.38 mm INCH 0 PLACE ± mm INCH	MM ONLY	4:1	METRIC	DRAWN BY: JMELTON CHECKED BY: SDANNELLEY APPROVED BY: SMILLER DATE: 2010/05/18 DATE: 2010/05/18 DATE: 2010/07/14
	ANGULAR ±1/2° DRAFT WHERE APPLICABLE MUST REMAIN WITHIN DIMENSIONS	MATERIAL NO. SEE TABLE	TITLE VHDM LITE 6 ROW, LF SIGNAL END BACKPLANE SALES DRAWING	DOCUMENT NO. SD-75195-001	SHEET NO. 2 OF 2	
	THIS DRAWING CONTAINS INFORMATION THAT IS PROPRIETARY TO MOLEX INCORPORATED AND SHOULD NOT BE USED WITHOUT WRITTEN PERMISSION					