

PART NUMBER	REVISION	DESCRIPTION	FEED TYPE
2150052-2	F	FINE CRIMP HEIGHT ADJUST	PNEUMATIC
7-2150052-2	F	PNEUMATIC AND CRIMP TOOLING KIT	PNEUMATIC
7-2150052-7	A	CRIMP TOOLING KIT	-

ATLANTIC VERSION TERMINATOR INTERFACE ADAPTER

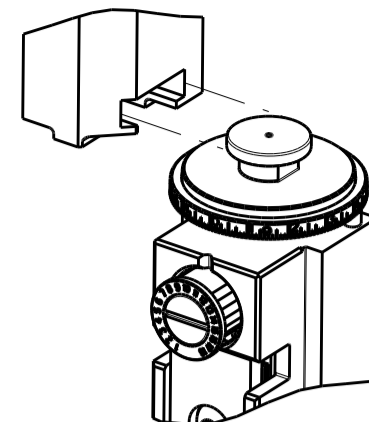

APPLICATOR DATA		
CRIMP	SIZE	TYPE
WIRE	2.54 mm [.100]	F
INSUL	3.05 mm [.120]	OV

APPLICATOR INSTRUCTIONS 408-35043

TERMINAL DATA: TE TERMINAL TE CRIMP SPECIFICATION			
TERMINAL NAME: RING TONGUE			
WIRE STRIP LENGTH		INSULATION DIAMETER RANGE	
5.50-6.50 mm [.217-.256 IN]		∅1.40-2.10 mm [.055-.083 IN]	
TERMINAL APPLICATION SPECIFICATION	114-2084		
TERMINALS APPLIED			
TE TERMINAL	TE TERMINAL	TE TERMINAL	TE TERMINAL
346102-2	346102-4		

WIRE SIZE	CRIMP HEIGHT mm [INCH]	CRIMP HEIGHT REFERENCE SETTING
1.00mm2	1.89+/-0.05 [.074+/-0.002]	4.7
0.75mm2	1.82+/-0.05 [.072+/-0.002]	5.4
0.50mm2	1.75+/-0.05 [.069+/-0.002]	6.0



- 1 RECOMMENDED SPARE PARTS
- 2 REFER TO SUPPLIED INSTRUCTION SHEET FOR CLEANING, LUBRICATION AND STORAGE OF APPLICATOR.
- 3 APPLY PART NUMBER 2-23419-6 LOCTITE TO THREADS OF ITEM 242.
- 4 CRIMP HEIGHT REFERENCE SETTING WAS THE SETTING USED WHEN THE APPLICATOR WAS QUALIFIED AT THE FACTORY. ADJUSTMENT MAY BE NECESSARY WHEN RUNNING APPLICATOR IN THE FIELD.
- 5 TERMINAL LUBRICANT IS RECOMMENDED.
- 6. UNLESS SPECIFIED OTHERWISE TORQUE VALUES SHALL BE USED PER DOCUMENT, 101-35000.
- 7 TERMINAL PITCH NOT COMPATIBLE WITH MECHANICAL FEED.

***WARNING**
ON INSTALLATION, SET WIRE DISC TO CRIMP HEIGHT REFERENCE SETTING FOR LARGEST WIRE SIZE. CRIMP HEIGHT REFERENCE SETTINGS GREATER THAN THE VALUE SHOWN MAY CAUSE DAMAGE TO THE CRIMP TOOLING. REFER TO THE INSTRUCTION SHEET FOR PROPER SETUP AND ADJUSTMENTS.

LOC	DIST	REVISIONS					
		REV	LTN	DESCRIPTION	DATE	OWN	APVD
A	66	D		ECR-19-012380	07AUG2019	MZ	YY
		E		ECR-19-012971	19AUG2019	FJ	TE
		E1		ECR-19-013984	06SEP2019	FJ	TE
		F		ECR-20-011779	20AUG2020	FZ	GB

-	1	1	2119641-1	FEED CAM, AIR FEED	248
-	1	1	2119082-8	CAM, SNAIL, INSULATION ADJUSTMENT	244
-	1	1	2079764-1	WASHER, WAVE SPRING, CREST-TO-CREST	243
-	1	1	2119083-1	RETAINER, INSULATION DIAL	242
-	1	1	2844940-4	AIR FEED MODULE	238
-	1	1	1-18028-0	WASHER, FLAT, REG M8	192
-	2	2	1-2168083-1	SCR, SKT HD CAP, RoHS, M3 X 6	189
-	REF	REF	994970-2	COUNTER, MAGNETIC	164
-	1	1	2119955-2	ASSY, LUBRICATOR, END FEED	84
-	1	1	455888-8	SPACER, CRIMPER	82
-	1	1	1803607-4	DOCUMENTATION PACKAGE	71
-	2	2	2-18032-2	SCR, SET, FLT PNT, M3 X 10.0	70
-	1	1	2119740-1	TAG, IDENTIFICATION	67
-	2	2	2168078-1	SCREW, DRIVE, RH, RoHS, 2 x .188	66
-	1	1	2168083-2	SCR, SKT HD CAP, RoHS, M4 X 8.0	60
-	1	1	5-18022-5	SCR, HEX HD CAP, M4 X 6.0	59
-	4	4	2168400-4	SHCS, LOW HEAD, RoHS, M4 X 8	57
-	2	2	2168083-8	SCR, SKT HD CAP, RoHS, M4 X 16	56
-	2	2	5018030-1	NUT, HEX, REG, RoHS, M3	54
-	2	2	986965-8	NUT, LOCK, HEX, TORQUE (M4)	53
-	1	1	2063961-9	FEED FINGER	51
-	1	1	18023-9	SCR, SKT HD CAP M4 X 6.0	49
-	1	1	2119655-5	APPLICATOR BASIC ASSEMBLY, EF	46
-	1	1	1803517-1	RAM ASSEMBLY, EF ATLANTIC	44
-	1	1	1803602-1	SCR, BHSC, RoHS (M8 X 25)	41
-	8	8	1-18028-2	WASHER, FLAT, REG M4	33
-	2	2	2168083-8	SCR, SKT HD CAP, RoHS, M4 X 16	31
-	2	2	2168083-2	SCR, SKT HD CAP, RoHS, M4 X 8.0	29
-	1	1	240639-1	STRIPPER (MACHINING)	27
-	2	2	1-2168083-6	SCR, SKT HD CAP, RoHS, M4 X 35	25
-	1	1	1752371-1	PLATE, STRIP GUIDE	24
-	2	2	2-22281-3	SPRING, COMPRESSION	22
-	1	1	1633168-1	ARM, STOCK DRAG	21
-	1	1	1-464452-6	DRAG, STOCK	20
-	1	1	2-1901696-7	STRIP GUIDE, REAR	19
-	1	1	2-1901695-7	STRIP GUIDE, FRONT	18
-	4	4	1-2079383-1	SCR, BHSC, RoHS (M6 X 12)	17
-	1	1	4-240641-6	SPACER	16
-	1	1	240644-1	PLATE, REAR SHEAR	11
-	-	-	-	-	10
-	1	1	690482-4	PLATE, FRONT SHEAR	9
-	1	2	1333218-8	ANVIL, COMBINATION	8
-	1	1	4-690474-5	BLADE, SLUG	7
-	1	1	2-240641-7	SPACER	5
-	1	1	238011-2	BLOCK, CRIMPER SPACER	4
-	1	2	1803139-2	CRIMPER, INSULATION OVERLAP PREMIUM	3
-	1	1	1-455888-6	SPACER, CRIMPER	2
-	1	2	456421-1	CRIMPER, WIRE	1
-	77	72	2	PART NO	ITEM NO

ATLANTIC VERSION
Shown on sheets 1 of 4 & 2 of 4
(Pacific version shown on sheets 3 of 4 & 4 of 4)

DIMENSIONS:		TOLERANCES UNLESS OTHERWISE SPECIFIED:		MATERIAL:		FINISH:	
mm	0 PLC ±	1 PLC ±	2 PLC ±	3 PLC ±	4 PLC ±	ANGLES	

OWN	H. HUANG	09FEB2012	CHK	S. XI	09FEB2012	APVD	S. XI	09FEB2012
NAME	Ocean End Feed Applicator							
PRODUCT SPEC	-							
APPLICATION SPEC	-							
SIZE	CAGE CODE	DRAWING NO	RESTRICTED TO					
A1	00779	2150052	-					
Customer Accessible Production Drawing								SCALE 1:1 SHEET 1 OF 4 REV F

LOC		DIST		REVISIONS			
A	66	P	LTM	DESCRIPTION	DATE	OWN	APVD
		-	-	SEE SHEET 1	-	-	-

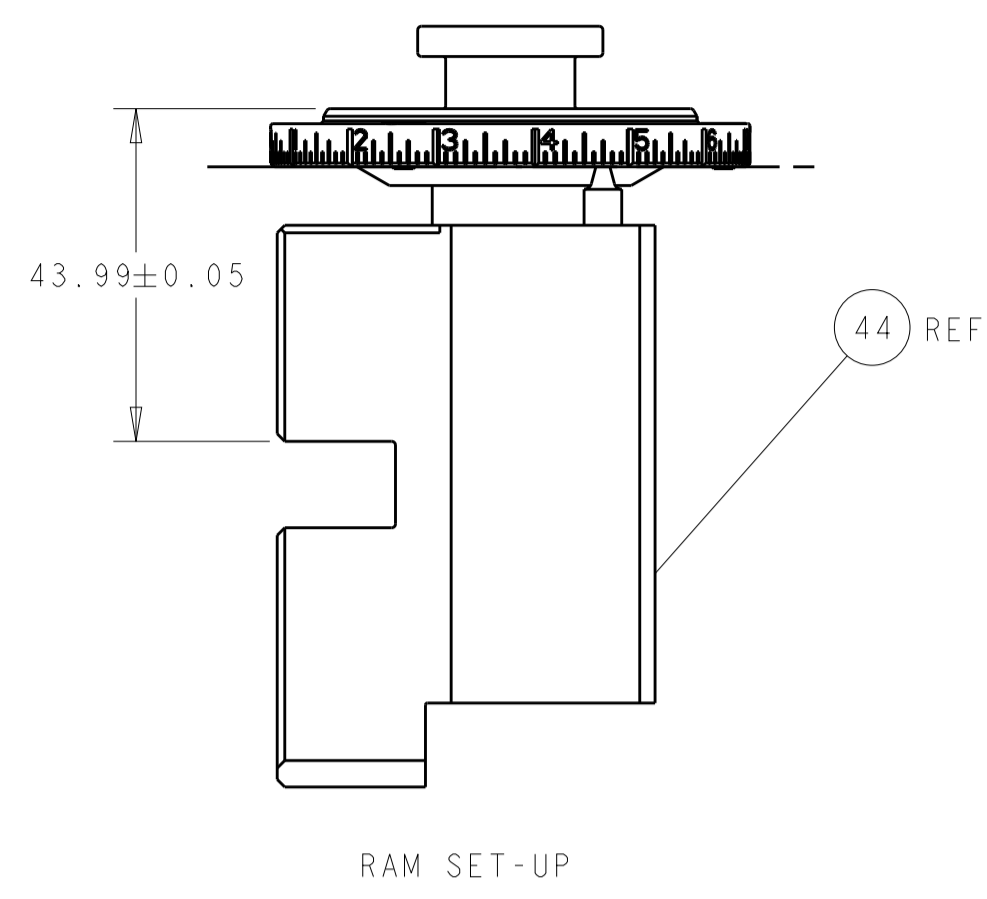

FEED TYPE

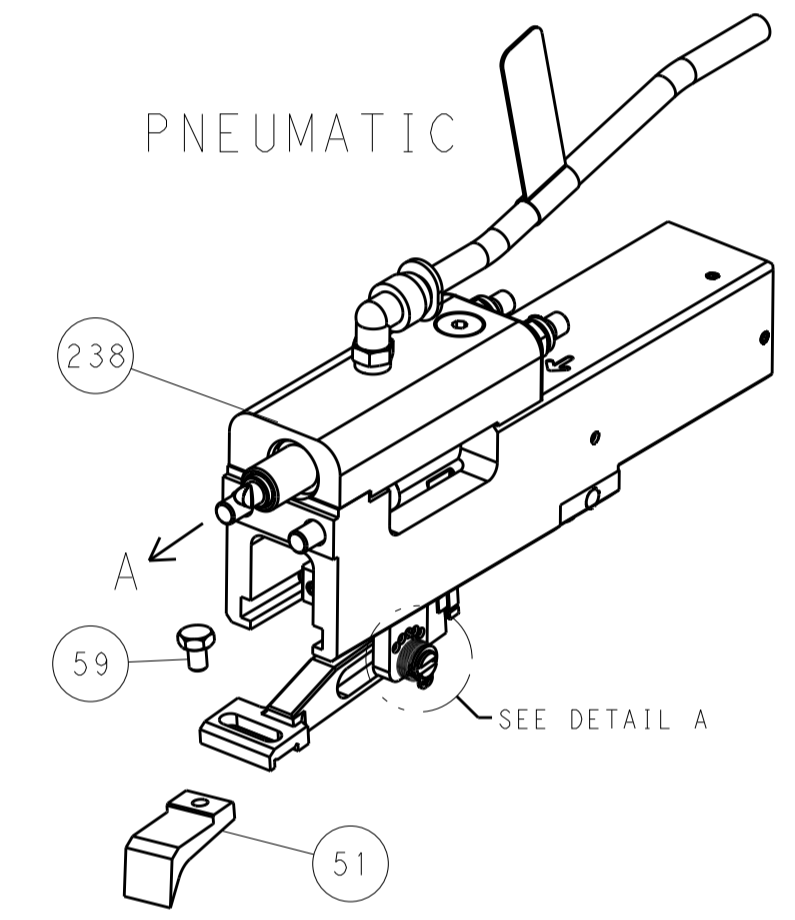
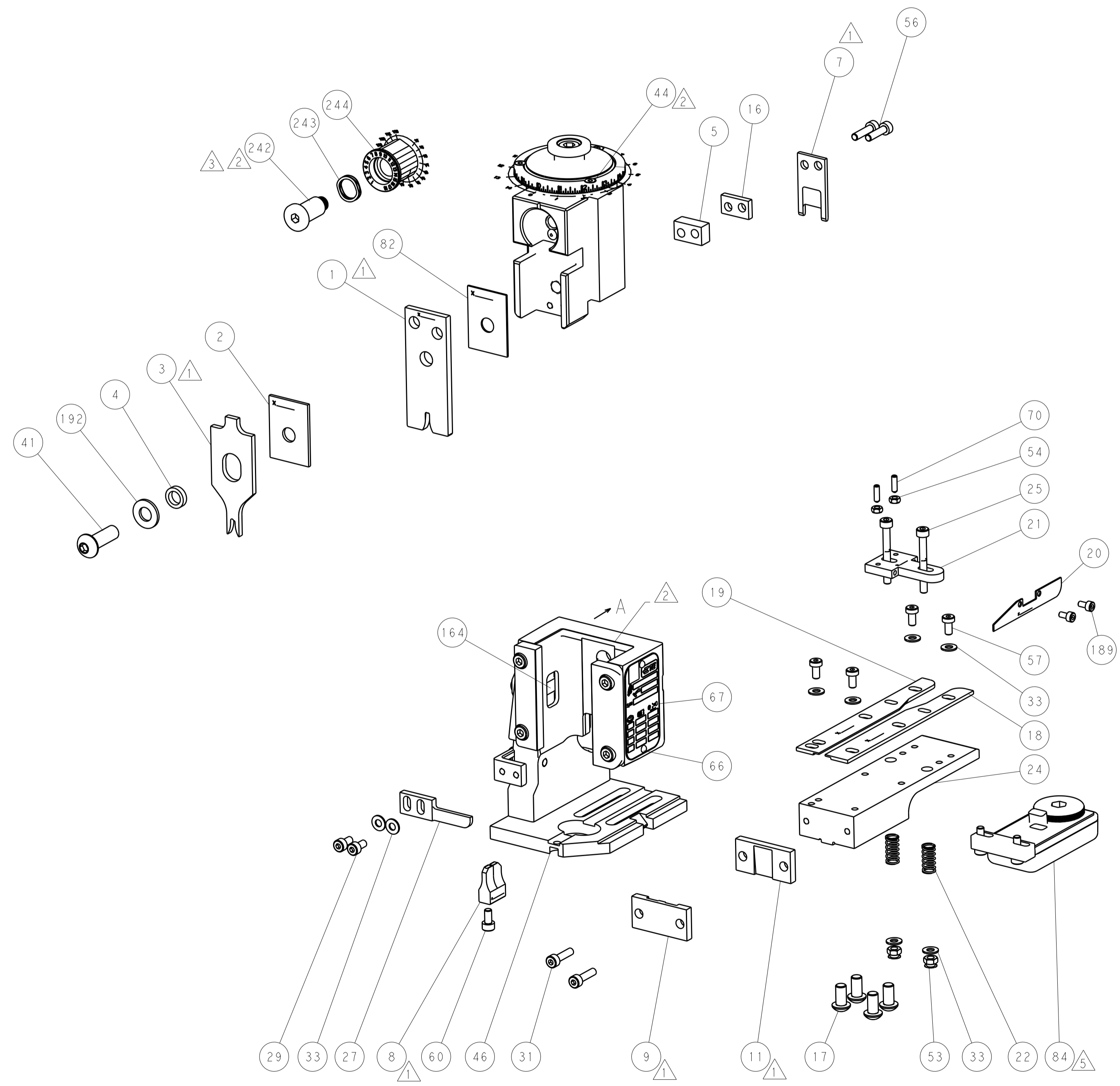

CAM POSITION

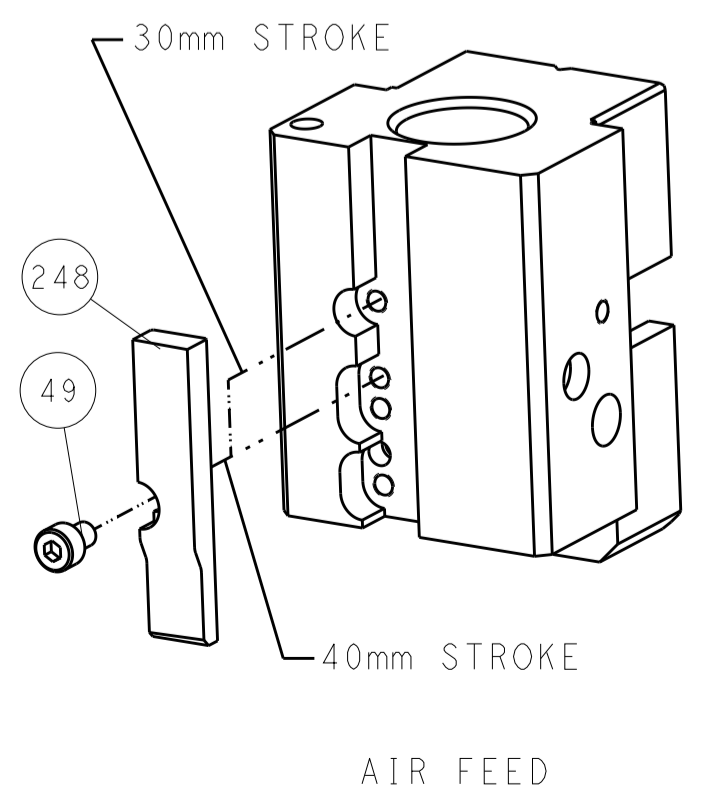

ATLANTIC VERSION
 Shown on sheets 1 of 4 & 2 of 4
 (Pacific version shown on sheets 3 of 4 & 4 of 4)

DIMENSIONS:		TOLERANCES UNLESS OTHERWISE SPECIFIED:		DWN K. HUANG 09FEB2012		TE Connectivity	
mm	0 PLC ±	1 PLC ±	2 PLC ±	3 PLC ±	4 PLC ±	5 PLC ±	Harrisburg, PA 17105-3608
	ANGLES ±	FINISH		CHK S.XI 09FEB2012	APVD S.XI 09FEB2012	NAME Ocean End Feed Applicator	
MATERIAL				PRODUCT SPEC	APPLICATION SPEC	SIZE	RESTRICTED TO
				WEIGHT		A1 00779 ©=2150052	
Customer Accessible Production Drawing				SCALE	1:1	SHEET 2 of 4	REV F

PART NUMBER	REVISION	DESCRIPTION	FEED TYPE
2-2150052-2	F	FINE CRIMP HEIGHT ADJUST	PNEUMATIC
7-2150052-7	A	CRIMP TOOLING KIT	-

PACIFIC VERSION TERMINATOR
 INTERFACE ADAPTER

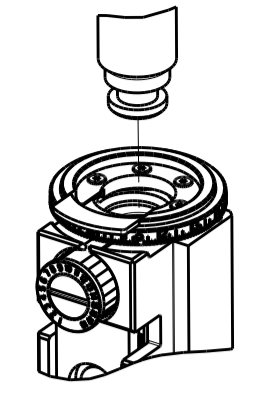

APPLICATOR DATA

CRIMP	SIZE	TYPE
WIRE	2.54 mm (.100)	F
INSUL	3.05 mm (.120)	OV

APPL INSTRUCTIONS
 408-35043

TERMINAL DATA: TE TERMINAL TE CRIMP SPECIFICATION

TERMINAL NAME: RING TONGUE

WIRE STRIP LENGTH	INSULATION DIAMETER RANGE
5.50-6.50 mm (.217-.256 IN)	∅1.40-2.10 mm (.055-.083 IN)

TERMINAL APPLICATION SPECIFICATION

TE TERMINAL	TE TERMINAL	TE TERMINAL	TE TERMINAL
346102-2	346102-4		

WIRE SIZE	CRIMP HEIGHT mm [INCH]	CRIMP HEIGHT REFERENCE SETTING
1.00mm2	1.89 +/- 0.05 [.074 +/- .002]	4.7
0.75mm2	1.82 +/- 0.05 [.072 +/- .002]	5.4
0.50mm2	1.75 +/- 0.05 [.069 +/- .002]	6.0



- RECOMMENDED SPARE PARTS
- REFER TO SUPPLIED INSTRUCTION SHEET FOR CLEANING, LUBRICATION AND STORAGE OF APPLICATOR.
- APPLY PART NUMBER 2-23419-6 LOCTITE TO THREADS OF ITEM 242.
- CRIMP HEIGHT REFERENCE SETTING WAS THE SETTING USED WHEN THE APPLICATOR WAS QUALIFIED AT THE FACTORY. ADJUSTMENT MAY BE NECESSARY WHEN RUNNING APPLICATOR IN THE FIELD.
- TERMINAL LUBRICANT IS RECOMMENDED.
- UNLESS SPECIFIED OTHERWISE TORQUE VALUES SHALL BE USED PER DOCUMENT, 101-35000.
- TERMINAL PITCH NOT COMPATIBLE WITH MECHANICAL FEED.

***WARNING**
 ON INSTALLATION, SET WIRE DISC TO CRIMP HEIGHT REFERENCE SETTING FOR LARGEST WIRE SIZE. CRIMP HEIGHT REFERENCE SETTINGS GREATER THAN THE VALUE SHOWN MAY CAUSE DAMAGE TO THE CRIMP TOOLING. REFER TO THE INSTRUCTION SHEET FOR PROPER SETUP AND ADJUSTMENTS.

LOC	DIST	REV	LTN	DESCRIPTION	DATE	DWN	APVD
A	66	-	-	SEE SHEET 1	-	-	-

-	1	2119082-8	CAM, SNAIL, INSULATION ADJUSTMENT	244	
-	1	2079764-1	WASHER, WAVE SPRING, CREST-TO-CREST	243	
3	-	1	2119083-1	RETAINER, INSULATION DIAL	242
-	1	2844940-4	AIR FEED MODULE	238	
-	1	1-18028-0	WASHER, FLAT, REG M8	192	
-	2	1-2168083-1	SCR, SKT HD CAP, RoHS, M3 X 6	189	
-	4	2079383-9	SCR, BHSC, RoHS (M6 X 20)	186	
-	REF	994970-2	COUNTER, MAGNETIC	164	
-	1	2119641-2	FEED CAM, AIR FEED	152	
-	1	2168083-8	SCR, SKT HD CAP, RoHS, M4 X 16	144	
-	1	2119655-6	APPLICATOR BASIC ASSEMBLY, EF	141	
-	1	1803518-1	RAM ASSEMBLY, EF PACIFIC	140	
5	-	1	2119955-2	ASSY, LUBRICATOR, END FEED	84
-	1	455888-8	SPACER, CRIMPER	82	
-	1	1803607-4	DOCUMENTATION PACKAGE	71	
-	2	2-18032-2	SCR, SET, FLT PNT, M3 X 10.0	70	
-	1	2119740-1	TAG, IDENTIFICATION	67	
-	2	2168078-1	SCREW, DRIVE, RH, RoHS, 2 x .188	66	
-	1	5-18022-5	SCR, HEX HD CAP, M4 X 6.0	59	
-	4	2168400-4	SHCS, LOW HEAD, RoHS, M4 X 8	57	
-	2	2168083-8	SCR, SKT HD CAP, RoHS, M4 X 16	56	
-	2	5018030-1	NUT, HEX, REG, RoHS, M3	54	
-	2	986965-8	NUT, LOCK, HEX, TORQUE (M4)	53	
-	1	2063961-9	FEED FINGER	51	
-	1	18023-9	SCR, SKT HD CAP M4 X 6.0	49	
-	1	1803602-1	SCR, BHSC, RoHS (M8 X 25)	41	
-	8	1-18028-2	WASHER, FLAT, REG M4	33	
-	2	2168083-8	SCR, SKT HD CAP, RoHS, M4 X 16	31	
-	2	2168083-2	SCR, SKT HD CAP, RoHS, M4 X 8.0	29	
-	1	240639-1	STRIPPER (MACHINING)	27	
-	2	1-2168083-6	SCR, SKT HD CAP, RoHS, M4 X 35	25	
-	1	1752371-1	PLATE, STRIP GUIDE	24	
-	2	2-22281-3	SPRING, COMPRESSION	22	
-	1	1633168-1	ARM, STOCK DRAG	21	
-	1	1-464452-6	DRAG, STOCK	20	
-	1	2-1901696-7	STRIP GUIDE, REAR	19	
-	1	2-1901695-7	STRIP GUIDE, FRONT	18	
-	1	4-240641-6	SPACER	16	
1	-	1	240644-1	PLATE, REAR SHEAR	11
-	-	-	-	10	
1	-	1	690482-4	PLATE, FRONT SHEAR	9
1	1	1333218-8	ANVIL, COMBINATION	8	
1	-	1	4-690474-5	BLADE, SLUG	7
-	1	2-240641-7	SPACER	5	
-	1	238011-2	BLOCK, CRIMPER SPACER	4	
1	1	1803139-2	CRIMPER, INSULATION OVERLAP PREMIUM	3	
-	1	1-455888-6	SPACER, CRIMPER	2	
1	1	456421-1	CRIMPER, WIRE	1	

PACIFIC VERSION
 Shown on sheets 3 of 4 & 4 of 4
 (Atlantic version shown on sheets 1 of 4 & 2 of 4)

DIMENSIONS: mm 		TOLERANCES UNLESS OTHERWISE SPECIFIED: 0 PLC ± 1 PLC ± 2 PLC ± 3 PLC ± 4 PLC ± ANGLES ± FINISH		DWN H. HUANG 09FEB2012 CHK S.XI 09FEB2012 APVD S.XI 09FEB2012		NAME: Ocean End Feed Applicator SIZE: A1 CAGE CODE: 00779 DRAWING NO: 2150052 SCALE: 1:1 SHEET 3 OF 4 REV F	
MATERIAL:				WEIGHT:			

LOC	DIST	REVISIONS			
P	LTN	DESCRIPTION	DATE	OWN	APVD
A	66	SEE SHEET 1			

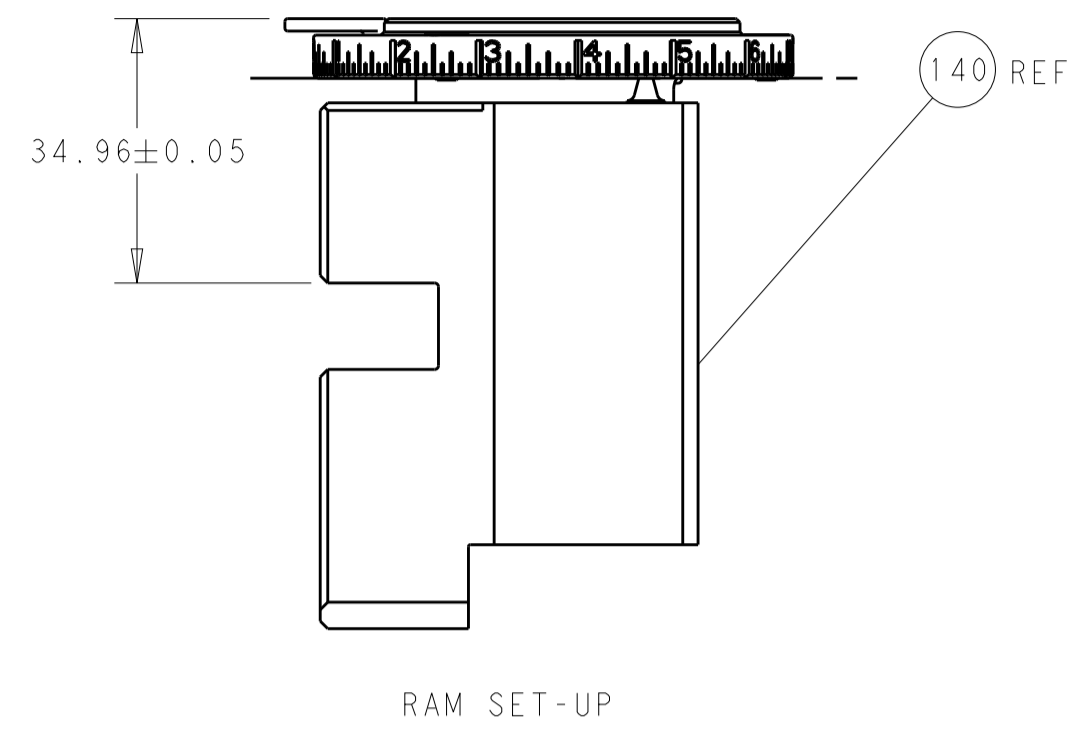

FEED TYPE

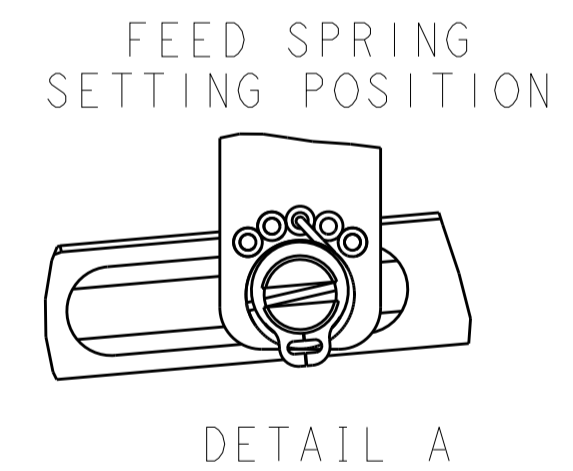
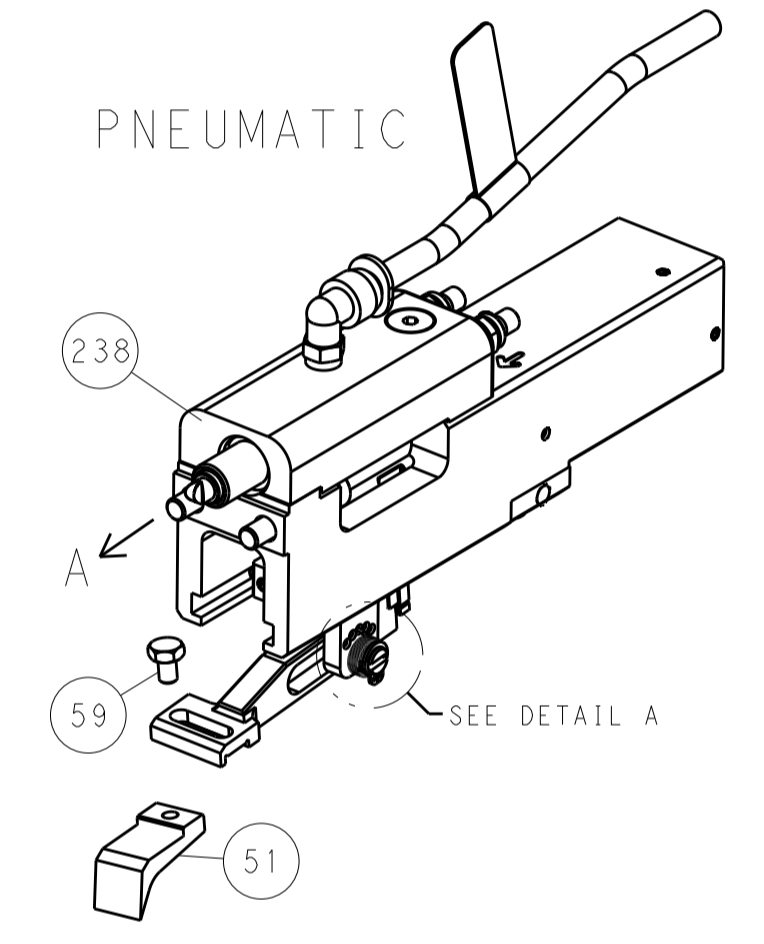
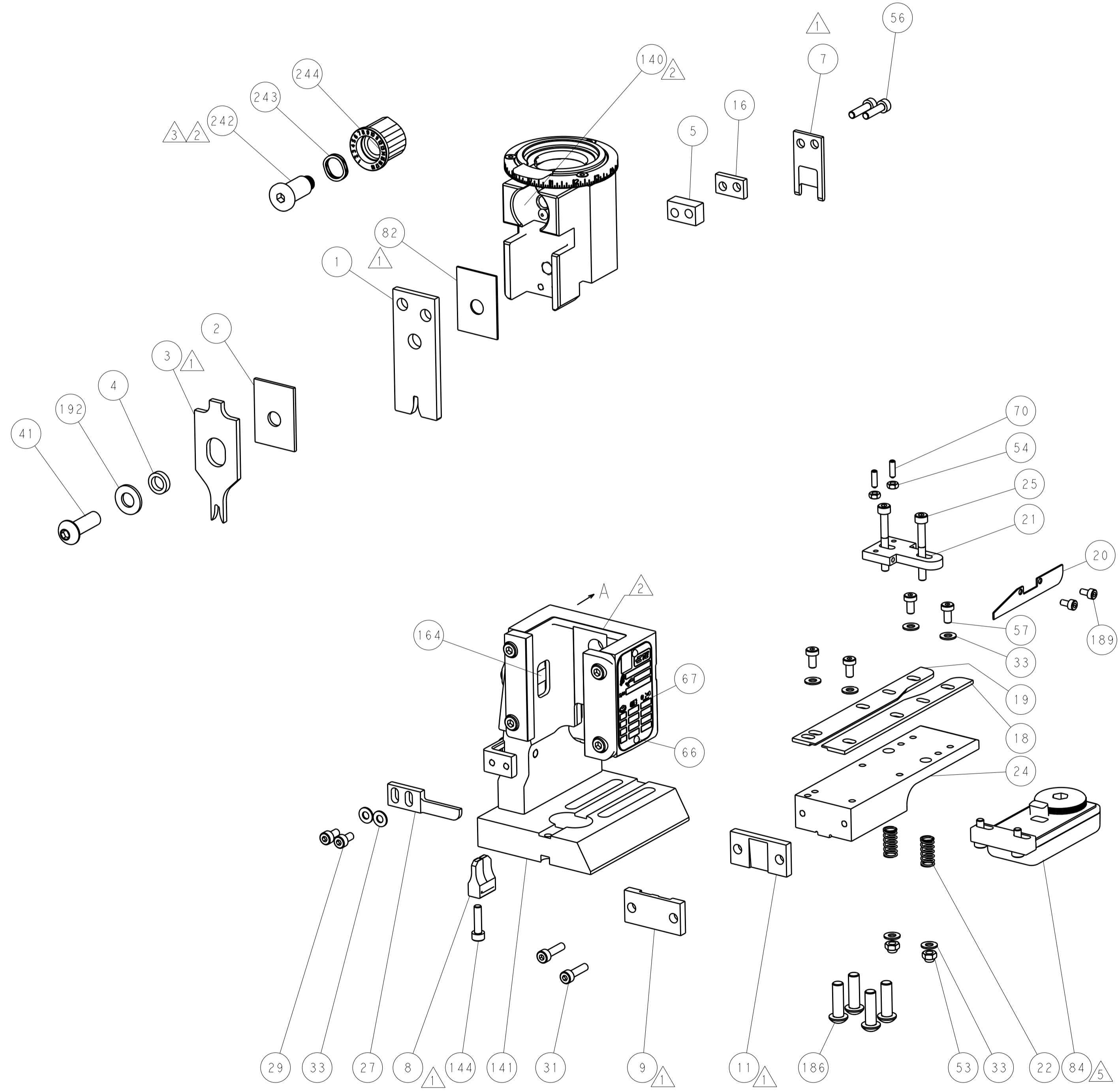

CAM POSITION

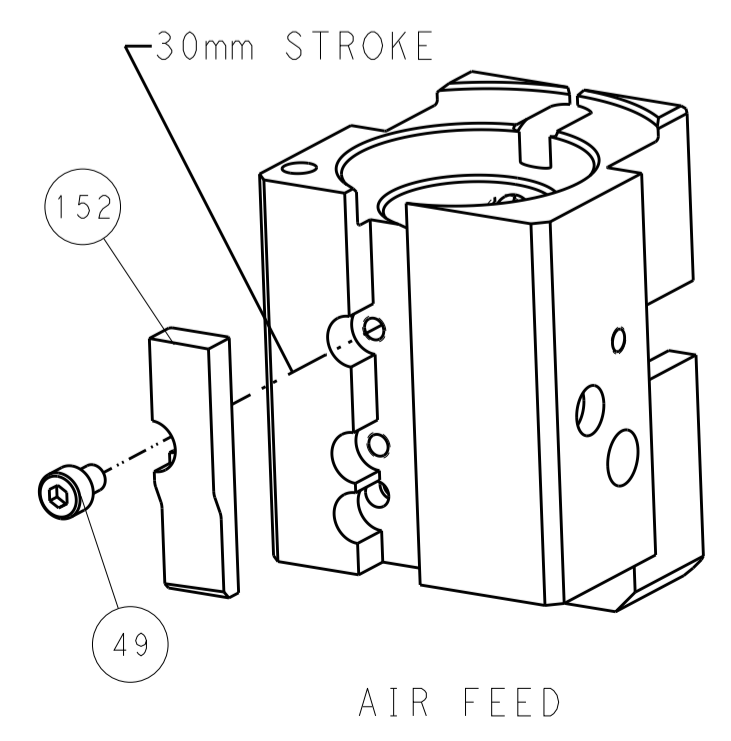

PACIFIC VERSION
 Shown on sheets 3 of 4 & 4 of 4
 (Atlantic version shown on sheets 1 of 4 & 2 of 4)

<small>THIS DRAWING IS UNPUBLISHED. RELEASED FOR PUBLICATION BY TYCO ELECTRONICS CORPORATION. ALL RIGHTS RESERVED.</small>		DWN: K. HUANG 09FEB2012 CHK: S. XI 09FEB2012 APVD: S. XI 09FEB2012	TE Connectivity Harrisburg, PA 17105-3608
DIMENSIONS: mm TOLERANCES UNLESS OTHERWISE SPECIFIED: 0 PLC ± 1 PLC ± 2 PLC ± 3 PLC ± 4 PLC ± ANGLES ±		NAME: Ocean End Feed Applicator PRODUCT SPEC: APPLICATION SPEC: WEIGHT:	SIZE: A1 CAGE CODE: 00779 DRAWING NO: C=2150052 RESTRICTED TO: F
MATERIAL:		FINISH:	SCALE: 1:1 SHEET: 4 OF 4 REV: F