

©1969 BY AMP INCORPORATED. ALL RIGHTS RESERVED. AMP PRODUCTS COVERED BY PATENTS AND/OR PATENTS PENDING.

THIS PRODUCT DESIGNED AND BUILT BY AMP INCORPORATED. NO LICENSE TO USE THAT DESIGN IN MANUFACTURE, OR TO USE ANY ISSUED OR PENDING PATENTS WHICH ARE INVOLVED, IS IMPLIED.

REVISIONS				
ZONE	LTR	DESCRIPTION	DATE	APPROVED
	A	REV. NOTE 1	LAB 10-15-73	LPA
	B	REVISED	DS 10-13-76	M.S.
	C	REV. PER E.C.N. 8691	AG 3-5-79	M.S.
	D	OBSOLETE - 2 ECN 53622	11-13-86	R.S.
	E	REVISED PER ECN S-3960	4-10-87	R.S.
	F	REV PER OH14-0192-05	1-06	PY
	G	REV PER ECO-12-009412	PY 6-21-12	DE

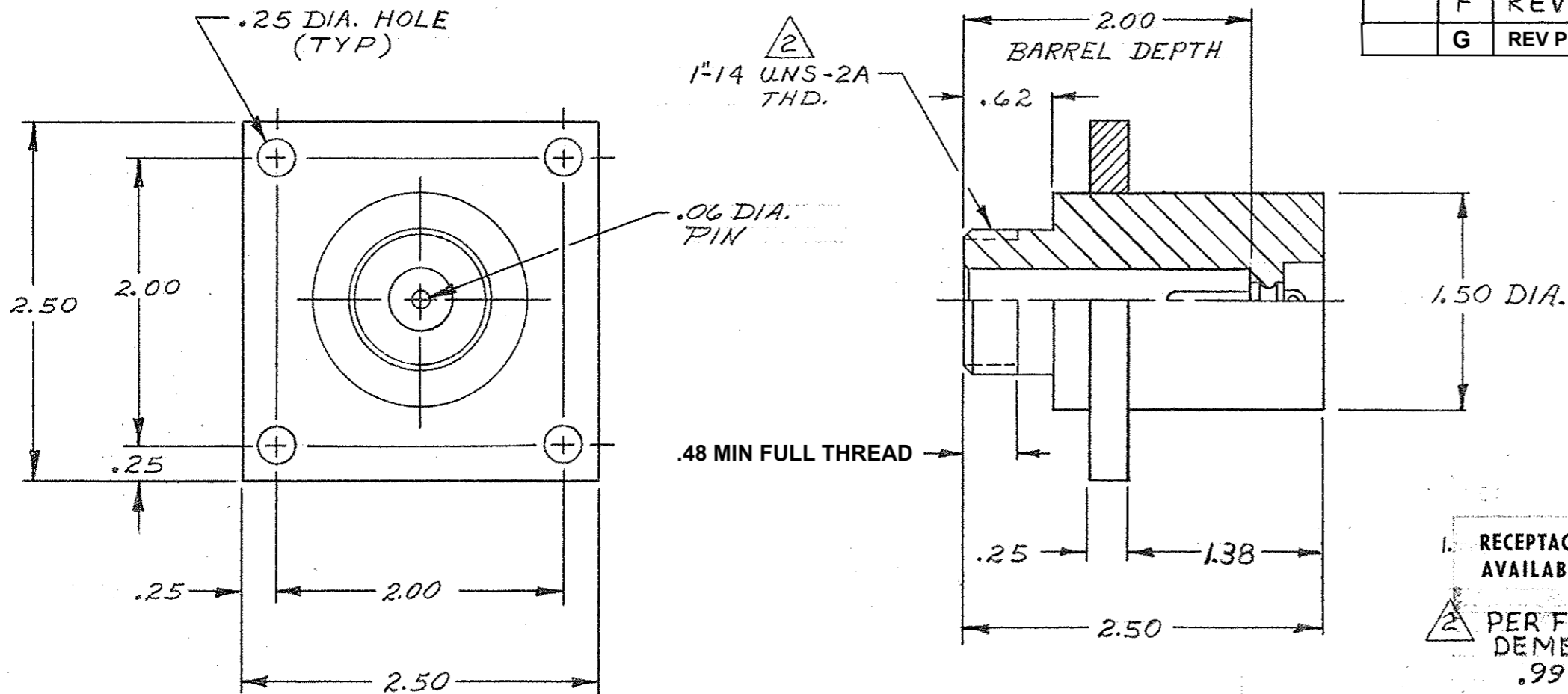

1. RECEPTACLE TO MATE WITH AMP LGH-4 LEAD ASSEMBLY, AVAILABLE SEPARATELY.
 2. PER FEDERAL STANDARD H-28 3 WIRE METHOD. DIMENSION OVER WIRES TO BE: .9975 - 1.0186.

ITEM NO.	DWG SIZE	PART OR IDENTIFYING NO.	NOMENCLATURE OR DESCRIPTION	SYMBOL
		5-850912-1	AS SHOWN WITH TIN PLATED PIN	
		OBSOLETE 850912-2	AS SHOWN WITH GOLD PLATED PIN	
		850912-1	AS SHOWN WITH TIN-LEAD PLATED PIN	

UNLESS OTHERWISE SPECIFIED: DIMENSIONS ARE IN INCHES TOLERANCES .00 ± .04 ANGLES .000 ± .015				CONTRACT NO. DR <i>L. Witt</i> 6-11-69		AMP INCORPORATED CAPITRON DIVISION ELIZABETHTOWN, PENNSYLVANIA	
MATERIAL: MOLDED GLASS EPOXY				CHK		NAME LGH-4 FLANGED RECEPTACLE ASS'Y RECESSED TERMINAL MOUNT (FOR BULKHEAD APPLICATION)	
FINISH: BLACK				APPD		DSGN APPD <i>S. Witt</i> 6-12-69	
NEXT ASSY		FINAL ASSY		OTHER APPD		SIZE B	CODE IDENT NO. 00779
QTY REQD		APPLICATION				NUMBER 850912	REV G
						SCALE H	WT
						SHEET 1 OF 1	

PRINT DIST
L 37