

GEN. ST.	01	02	03	04	05	06	07	08	0D	50	60	70	80	90																	
INT. ST.	10	11	12	13	14	18	20	31	32	33	34	38	39	40	42	43	44	45	46	48	56	70	72	73	75	76	81	82	83	84	88

REV.	DATE	DESCRIPTION	BY	C'K'D'
A	2001-09-14	CONVERSION REVISION 01	KN	
B	2002-05-28	EC B20086	MF	
C	2005-10-17	105-0196	ALEX B	BKP
D	2006-08-10	106-0145	ALEX B	BKP

LOADING PATTERN MATING SIDE

f	6	6	6	6	6	6	6	6	6	6	/										6	6	6	6	6	6	6	6	6	6	6
e	5	5	5	5	5	5	5	5	5	5											A	A	A	A	A	A	G	4	4	6	6
d	5	5	5	5	5	5	5	5	5	5											A	A	A	A	A	A	G	4	4	6	6
c	5	5	5	5	5	5	5	5	5	5											A	A	A	A	A	A	G	4	4	6	6
b	5	5	5	5	5	5	5	5	5	5											A	A	A	A	A	A	G	4	4	6	6
a	5	5	5	5	5	5	5	5	5	5											A	A	A	A	A	A	G	4	4	6	6
Z	0	0	0	0	0	0	0	0	0	0	0	0	0	0	0	0	0	0	0	0	0	0									
P	0	0	0	0	0	0	0	0	0	0	1	5	2	5																	
SO	1	5	0	5	2	5																									

LOADED CONNECTOR ASSEMBLY  
(FOR EXAMPLE)

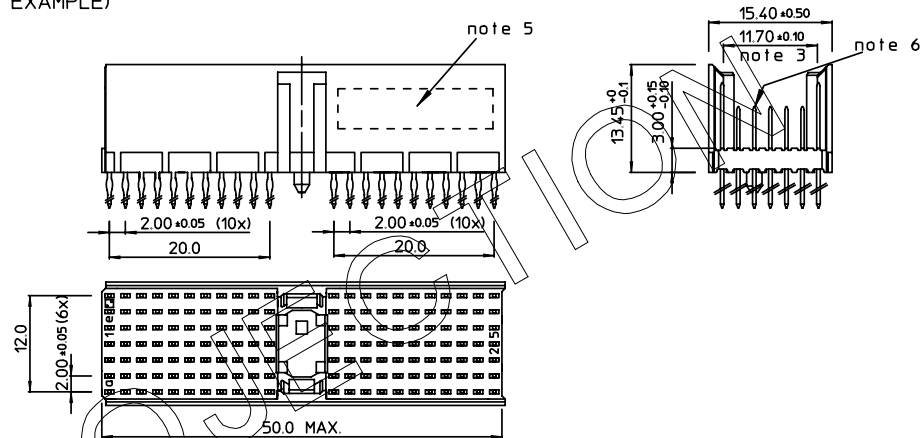

CONTACT OVERVIEW

SEATING PLANE FOR CONNECTOR

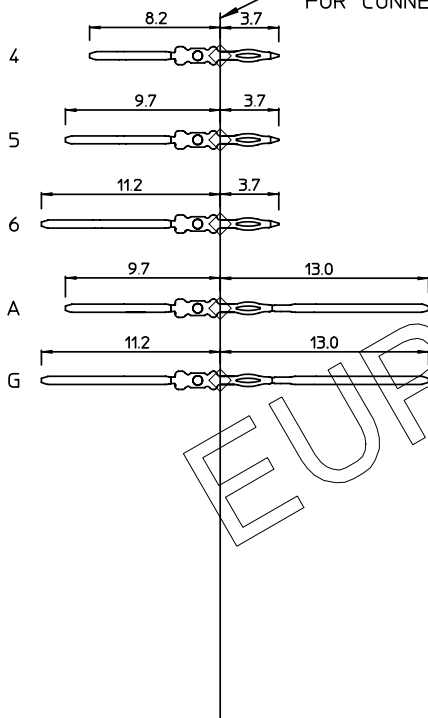

LAY-OUT P.C.B.-HOLE

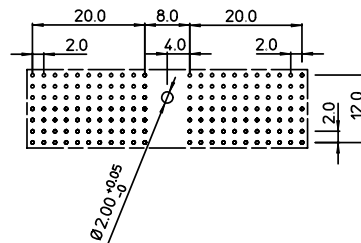

LEAD FREE INDICATOR : LF = LEAD FREE  
(DIGIT 15 & 16)

HM2P07PKP2H5

PLATING CODE (DIGIT 13 AND 14)  
(REF DWG No. BS,C ,201844,003)

NOTES:

1. THIS PRODUCT IS CSA APPROVED.
2. THIS PRODUCT IS UL RECOGNIZED.
3. MEASURED AT THE BOTTOM.
4. MATERIAL CONTACT: PHOSPHORBRONZE  
HOUSING: CREAM WHITE GLASSFILLED POLYESTER UL-94V0
5. CONNECTOR PRINTED WITH P/N AND DATE CODE.
6. FOR ACTUAL CONTACT LOADINGS, SEE LOADING PATTERN MATING SIDE.
7. SHAPE OF CONNECTOR HOUSING CAN ALTER DEPENDING ON PRODUCTION LOCATION.
8. THE PRODUCT (LF) MEETS EUROPEAN UNION DIRECTIVES AND OTHER COUNTRY REGULATIONS AS DESCRIBED IN GS-22-008
9. FOR RECOMMENDED PTH DIMENSIONS REFER DRAWING : BS,A ,201572,001

1DEC ± 0,2 2DEC ± 0,1 ANGLES ± 1°	<b>APPR.</b> DRAFT CHECKED	<b>DATE</b> 2001-04-23 M.Fret	<b>SIGN.</b> M.Fret	MPACS 5+2R STR HDR SG PF CONN TYPE A
WE RESERVE THE RIGHT TO CHANGE DIMENSIONS OR REQUIREMENTS WITHOUT PRIOR NOTICE.	PROD. MGR. PR. ENG. MGR. PR. MGT. MGR.			<b>CAT. No.</b> HM2P07PKP2H5----
ALL DIMENSIONS IN MM			<b>FCJ</b> www.fciconnect.com	SCALE

REFERENCES



BS,C ,202788 ,113

D

THIS IS OUR EXCLUSIVE PROPERTY. IT IS NOT TO BE COPIED, REPRINTED OR DISCLOSED TO A THIRD PARTY, NOR USED FOR MANUFACTURING WITHOUT OUR WRITTEN CONSENT, AND HAS TO BE RETURNED TO US IN CASE OF NO USAGE

DIT IS ONZE EIGENDOM EN MAG NIET NAEMAAKT, HERDRUKT, OVERGEMAKT AAN DERDEN, NOCH VOOR FABRIKATIE GEBRUIKT WORDEN, ZONDER ONZE SCHRIFTELIJKE TOELATING. BIJ NIET GEBRUIK IS TERUGZENDING VERPLICHT.

PDM: Rev:D

STATUS: Released

CUSTOMER DRAWING, REVISION  
Printed: Dec 03, 2007